

# Power Grip Grinding Mill Clutches

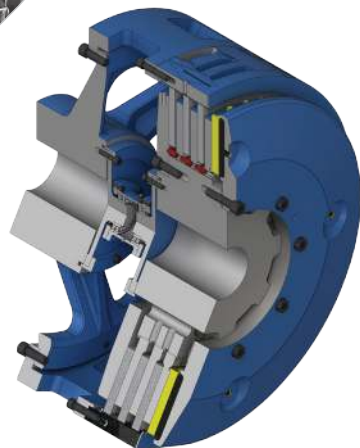

## Grinding Mill Clutches

Power Grip Grinding Mill Clutches are the best heavy duty option for ball, pebble, rod, AG and SAG grinding mill applications. High inertia loads are brought on line quickly and smoothly where controlled starts are required. WPT's Power Grip clutches are designed to use a minimal amount of air volume.

- Reduces power demand for high inertia load starts
- Disc design has more torque capacity and lining area than drum style products
- Suitable for jogging and inching

### Specifications with Axial Locking

Torque Rating @ 100 psi (7 bar)		Maximum Speed	Maximum Slip Speed	Weight and Inertia				Lining Area	Bore Range	
Model	Static Torque			Total Weight	Total Inertia	Ring, FD, & QC Adapter Weight	Ring, FD, & QC Adapter Inertia		Clutch	Adapter
		lbf-in (N-m)	r/min	r/min	lb (kg)	lb-ft <sup>2</sup> (kgm <sup>2</sup> )	lb (kg)	lb-ft <sup>2</sup> (kgm <sup>2</sup> )	in <sup>2</sup> (cm <sup>2</sup> )	in (mm)
336	1,490,000 (168000)	900	640	3,080 (1400)	3,650 (153)	616 (279)	932 (39)	4,100 (26500)	9.00 (228.6)	9.75 (247.7)
242	1,540,000 (174000)	750	550	5,400 (2450)	10,600 (445)	2,820 (1280)	6,980 (293)	3,200 (20600)		
342	2,290,000 (259000)	750	550	6,340 (2880)	13,000 (546)	3,620 (1640)	9,370 (394)	4,800 (30900)	11.00 (279.4)	12.56 (319.1)
248	2,750,000 (311000)	650	480	8,200 (3720)	20,400 (857)	4,000 (1810)	12,700 (533)	4,800 (30900)	12.00 (304.8)	14.00 (355.6)
348	4,100,000 (463000)	650	480	9,340 (4240)	23,100 (970)	4,220 (1910)	13,700 (575)	7,200 (46400)		
260	8,320,000 (632000)	525	380	13,400 (6070)	45,500 (1910)	7,290 (3310)	19,000 (799)	7,800 (50300)	15.00 (381.0)	16.75 (425.5)
360	8,320,000 (940000)	525	380	14,900 (6760)	53,600 (2250)	6,400 (2900)	31,300 (1310)	11,700 (75500)		
460	11,100,000 (1250000)	525	380	16,900 (7670)	61,500 (2580)	7,250 (3290)	35,500 (1490)	15,600 (101000)		

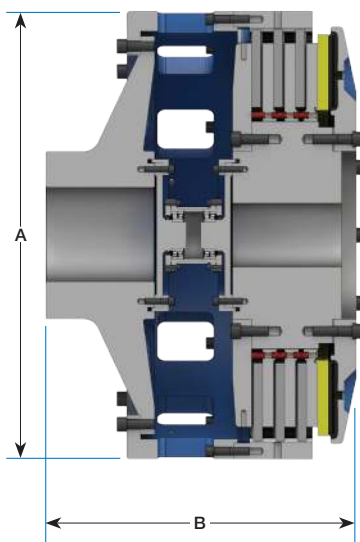

### Dimensions with Axial Locking

Size	A		B	
	in	(mm)	in	(mm)
336			39 3/4	(1009.9)
436	41	(1041.4)	47 13/16	(1214.9)
242			30 1/8	(765.6)
342	49 1/4	(1251.0)	34 3/8	(873.1)
248			43 9/16	(1108.0)
348	56	(1422.4)	39 1/2	(1003.3)
260			42 1/2	(1079.5)
360	66 3/4	(1695.5)	46 1/4	(1174.8)
460			49 7/8	(1267.0)

Consult WPT Application Engineering for application assistance and applicable service factors.

Larger bore sizes may be accommodated, consult WPT Application Engineering.

Dynamic torque is 75% of static torque.

## Axial Locking Device

An optional axial locking device that holds the grinding mill electric motor shaft in the magnetic center.

### Specifications without Axial Locking

Model	Torque Rating @ 100 psi (7 bar)		Maximum Slip Speed r/min	Weight and Inertia				Lining Area in <sup>2</sup> (cm <sup>2</sup> )	Bore Range	
	Static Torque lb-in (N-m)	Maximum Speed r/min		Total Weight lb (kg)	Total Inertia lb-ft <sup>2</sup> (kgm <sup>2</sup> )	Ring, FD, & QC Adapter Weight lb (kg)	Ring, FD, & QC Adapter Inertia lb-ft <sup>2</sup> (kgm <sup>2</sup> )		Clutch in (mm)	Adapter in (mm)
224H	330,000 (37300)	1350	950	1,180 (536)	746 (31.3)	557 (253)	436 (18.3)	1,200 (7570)	4.75 (120.7)	7.00 (177.8)
324H	488,000 (55100)	1350	950	1,450 (657)	864 (36.3)	622 (282)	487 (20.4)	1,800 (11400)		
230H	648,000 (73200)	1100	760	2,210 (1000)	1,970 (82.9)	997 (452)	1,060 (44.6)	1,700 (10800)	7.00 (177.8)	8.00 (203.2)
330H	954,000 (108000)	1100	760	2,640 (1200)	2,530 (106)	1,070 (486)	1,210 (50.6)	2,500 (16200)		
236	1,010,000 (114000)	900	640	3,000 (1360)	3,930 (165)	1,250 (568)	1,960 (82.3)	2,700 (17700)	9.00 (228.6)	9.75 (247.7)
336	1,490,000 (168000)	900	640	3,770 (1710)	4,870 (204)	1,440 (655)	2,440 (102)	4,100 (26500)		
242	1,540,000 (174000)	750	550	4,740 (2150)	9,100 (382)	2,380 (1080)	5,710 (240)	3,200 (20600)	11.00 (279.4)	12.56 (319.1)
342	2,290,000 (259000)	750	550	5,550 (2520)	10,900 (458)	2,610 (1180)	6,620 (278)	4,800 (30900)		
248	2,750,000 (311000)	650	480	7,570 (3430)	18,500 (777)	3,560 (1610)	10,600 (445)	4,800 (30900)	12.00 (304.8)	14.00 (355.6)
348	4,100,000 (463000)	650	480	8,720 (3960)	20,600 (865)	3,860 (1750)	11,900 (500)	7,200 (46400)		
260	5,590,000 (632000)	525	380	12,900 (5860)	43,200 (1810)	5,710 (2590)	24,600 (1030)	7,800 (50300)		
360	8,320,000 (940000)	525	380	14,700 (6670)	51,700 (2170)	6,490 (2940)	29,300 (1230)	11,700 (75500)	15.00 (381.0)	15.00 (355.6)
460	11,100,000 (1250000)	525	380	16,700 (7570)	59,400 (2490)	7,190 (3260)	33,500 (1410)	15,600 (101000)		

### Dimensions without Axial Locking

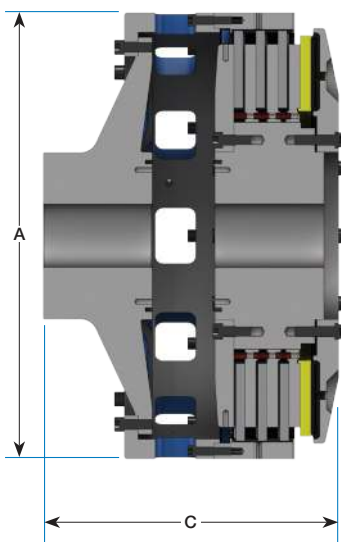

Size	A		C	
	in	(mm)	in	(mm)
224H	28	(711.2)	11	(279.4)
324H			21 1/2	(546.1)
230H	34	(863.6)	22 5/8	(574.7)
330H			25 1/8	(638.2)
236			22 5/8	(574.7)
336	41	(1041.0)	26 3/4	(679.5)
436			29 5/8	(752.5)
242	49 1/4	(1251.0)	24 1/2	(622.3)
342			27 9/16	(700.1)
248	56	(1422.0)	29 3/8	(746.1)
348			32 1/8	(816.0)
260			40	(1016.0)
360	66 3/4	(1695.5)	43 3/4	(1111.3)
460			47 3/8	(1203.5)



# Grinding Mill Selection Guide



Power, hp (kW)	Speed r/min																												
	120	124	129	133	138	144	150	157	164	172	180	190	200	212	225	240	257	277	300	327	360	430	450	514	600	720	900	1200	
0 (0)																													
125 (130)																													
150 (112)																													
175 (130)																													
200 (149)																													
250 (186)																													
300 (224)																													
350 (261)																													
400 (298)																													
450 (336)																													
500 (373)																													
600 (447)																													
700 (522)																													
800 (597)																													
900 (671)																													
1000 (746)	236																												
1250 (932)																													
1500 (1120)																													
1650 (1230)																													
1750 (1300)																													
2000 (1490)																													
2200 (1640)																													
2250 (1680)																													
2500 (1860)																													
2750 (2050)																													
3000 (2240)																													
3500 (2610)																													
3800 (2830)																													
4000 (2980)																													
4400 (3280)																													
4800 (3580)																													
5000 (3730)																													
5500 (4100)																													
6000 (4470)																													
6500 (4850)																													
7000 (5220)																													
7500 (5590)																													
8000 (5970)																													
8500 (6340)																													
9000 (6710)																													
9500 (7080)																													
10000 (7460)																													
11000 (8200)																													
11500 (8580)																													
12000 (8950)																													

Grinding Mill Selection Guide is for reference only. For full warranty consideration, a data sheet must be turned into WPT Power and complete review performed by WPT Power Applications Engineering.