

**Magnum Brakes**

The Wichita Magnum Brake sets new standards in performance, safety and serviceability. The Magnum is easy to apply and simple to service. It offers high heat dissipation capability for continuous operation and dynamic torque capacities to 14,160 lb.in.

See pages 83 thru 87.

EP - Extra Performance Brakes

Wichita's EP is a modular design brake available in three sizes. Torque can be varied both by changing air pressure and controlling individual friction elements. External fins assure maximum heat dissipation. Optional wire guard protects personnel, allows continued air movement.

See pages 88 thru 93.

Mistral Brakes

Specifically designed for the corrugating industry, Wichita's new Mistral mill roll stand tension brake handles the demanding tensioning requirements of modern corrugating equipment's higher 1140 ft./minute speeds. Dynamic torque to 5310 lb.in., up to 3.5 thermal horsepower.

See pages 94 thru 97.

Magnum Brakes

- Totally enclosed, no guard required**
- Wide range of torque capacities**

Wichita's Magnum series of unwind tension brakes offer high performance in compact, easy to install packages. Air vents and an impeller-type disk are tuned to achieve highly efficient air flow. Heat dissipation is further enhanced by the use of an integral fan (optional). Four sizes are available with torque capacities from 17 lb.in. through 14,160 lb.in.



*Totally enclosed
no guard
required*

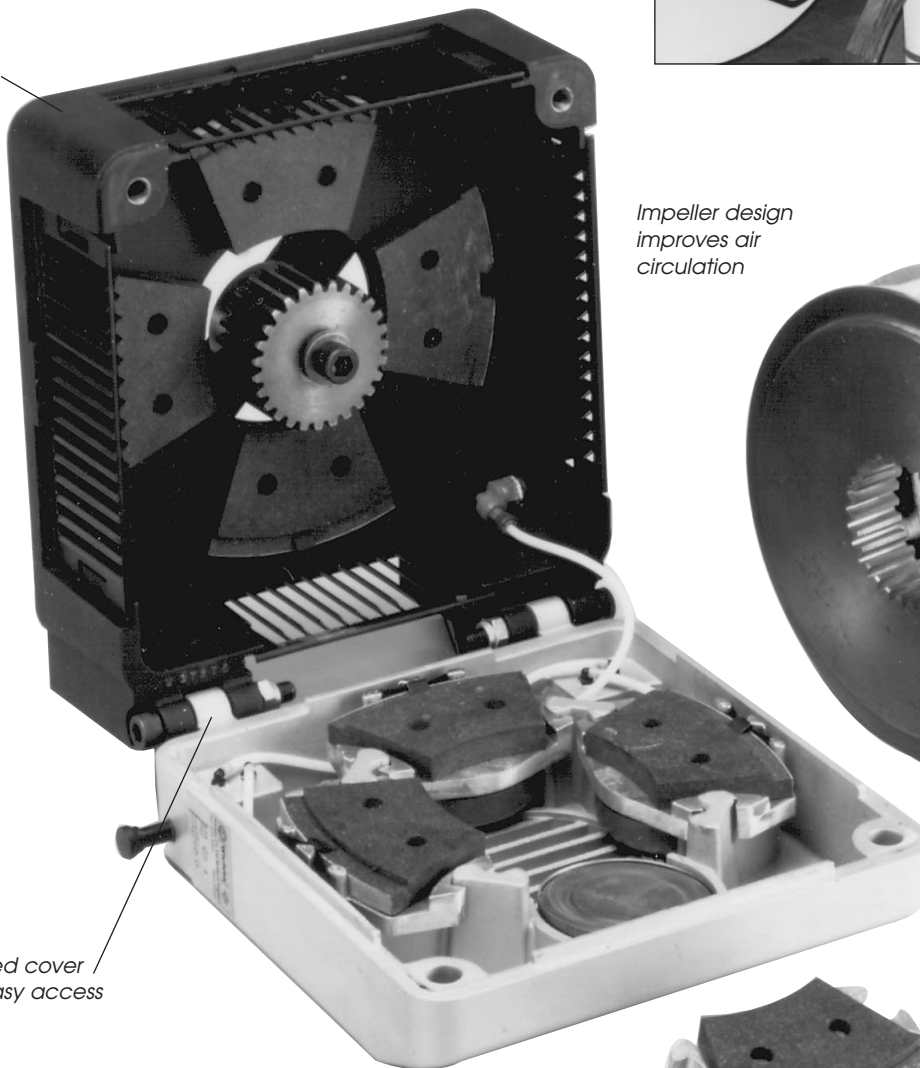

*Hinged cover
for easy access*

*Impeller design
improves air
circulation*



*Optional blower
increases heat
capacity*



*Quick replacement
friction pads*

Magnum Brakes

Tension brakes are selected by calculating the thermal energy (heat) generated during the unwind and choosing a brake with an equal or greater heat dissipation rating. The brake selection is then based on:

1. Maximum roll speed
2. Maximum torque needed to produce desired tension
3. Brake's heat dissipation capacity
4. Brake's maximum bore

Selecting a Brake for an unwind application

To properly select a tension brake for an unwind application, the following information is needed:

Max. Roll Dia. 60 in.
 Max. Web Width 36 in.
 Max. Web Speed 1200 fpm
 Max. Tension 2.0 pli
 Air Pressure Available 80 psi
 Min. Roll Dia. 6 in.
 Min. Web Width 34 in.
 Min. Web Speed 400 fpm
 Min. Tension 1.5 pli
 Shaft Size 2.00

Calculations

Using the calculations below, consult the Specifications Chart on page 85.

The brake selected for this application is a Magnum 340/3 with 2.00 bore.

$$\begin{aligned} \text{Max. Tension} &= \text{Max pli} \times \text{Max. Web Width} \\ &= 2 \times 36 = 72 \text{ lbs.} \end{aligned}$$

$$\begin{aligned} \text{Max. Torque} &= \frac{\text{Max. Tension} \times \text{Max. Roll Dia.}}{2} \\ &= \frac{72 \times 60}{2} = 2,160 \text{ lb.in.} \end{aligned}$$

$$\begin{aligned} \text{Max. rpm} &= \frac{\text{Max. Web Speed} \times 3.82}{\text{Min. Roll Dia.}} \\ &= \frac{1,200 \times 3.82}{6} = 764 \text{ rpm} \end{aligned}$$

$$\begin{aligned} \text{Effective Cooling Speed (rpm)} &= \frac{\text{Max. Web Speed} \times 7.64}{(\text{Max. Roll Dia.} + \text{Min. Roll Dia.})} \\ &= \frac{1200 \times 7.64}{(60 + 6)} = 139 \text{ rpm} \end{aligned}$$

$$\begin{aligned} \text{Heat H.P.} &= \frac{\text{Max. Tension} \times \text{Max Web Speed}}{33,000} \\ &= \frac{72 \times 1200}{33,000} = 2.6 \text{ Heat HP} \end{aligned}$$

$$\begin{aligned} \text{Min. Tension} &= \text{Min. pli} \times \text{Min. Web Width} \\ &= 1.5 \times 34 = 51 \text{ lbs.} \end{aligned}$$

$$\begin{aligned} \text{Min. Torque} &= \frac{\text{Min. Tension} \times \text{Min. Roll Dia.}}{2} \\ &= \frac{51 \times 6}{2} = 153 \text{ lb.in.} \end{aligned}$$

$$\begin{aligned} \text{Min. rpm} &= \frac{\text{Min. Web Speed} \times 3.82}{\text{Max. Roll Dia.}} \\ &= \frac{400 \times 3.82}{60} = 25.5 \text{ rpm} \end{aligned}$$

How to Select

1. Select a brake with equal or greater thermal capacity. The 340/3 has 2.9 hp @ 139 rpm. The requirement is 2.6 thp @ 139 rpm.
2. Check torque capacity vs. required 340/3 = 3090 lb.-in. @ 80 psi. The requirement equals 2160 lb.in.
3. Check Maximum Bore. The requirement is 2.00 in. The 340/3 maximum bore is 2.25 inches.
4. Check Maximum rpm. The requirement is 764 rpm. The maximum rpm for the 340/3 is 2040 rpm with standard disc.

$$\begin{aligned} \text{Max. Air Pressure Required} &= \frac{\text{Max. Torque} \times 80 \text{ psi}}{\text{Catalog Torque Rating}} \\ &= \frac{2,160 \times 80}{3090} = 56 \text{ psi} \end{aligned}$$

$$\begin{aligned} \text{Min. Air Pressure Required} &= \frac{\text{Min. Torque} \times 80 \text{ psi}}{\text{Catalog Torque Rating}} \end{aligned}$$

$$\begin{aligned} \text{With Three Actuators} &= 153 \times 80/3090 = 4 \text{ psi} \end{aligned}$$

$$\begin{aligned} \text{With One Actuators} &= 153 \times 80/1030 = 12 \text{ psi} \end{aligned}$$



Specifications

Model No.	Dynamic Slipping Torque Cap. lb.in. ⁽¹⁾		Brake	Heat Transfer Capacity for Continuous Operation HP ⁽²⁾				Maximum Speed (rpm)		Inertia of brake disc + hub lb.ft. ²	Weight	
	Min 3 PSI	Max 80 PSI		50 rpm	100 rpm	200 rpm	500 rpm	Medium Speed brake disc (rpm)	High Speed brake disc (rpm)		Total Brake lb.	Brake disc + Hub lb.
260/1LC	17	440	Mag.	1.3	1.5	1.9	2.9	2530	4427	.74	31	13.7
260/1	26	660										
260/2LC	43	880										
260/2	60	1320										
260/3LC	60	1320										
260/3	85	1980										
260/4LC	85	1760										
260/4	113	2640	Mag.+	1.7	2.1	2.8	4.0	FAN	FAN	FAN	FAN	
340/1LC	35	687	Mag.	2.3	2.7	3.3	4.7	2040	3570	2.4	45	23
340/1	43	1030										
340/2LC	70	1373	Mag. Thin	1.1	1.3	1.6	2.6					
340/2	86	2060										
340/3LC	95	2060	Mag. Thin	2.4	2.5	2.7	3.1					
340/3	129	3090										
340/4LC	129	2748	Mag. B	3.6	4.0	4.8	5.6					
340/4	172	4120										
340/5LC	163	3435	Mag.+	3.9	4.3	5	5.7					
340/5	215	5150										
340/6LC	198	4120	Mag.+	3.9	4.3	5	5.7					
340/6	258	6180										
400/2LC	86	1774	Mag.	3.5	4.0	5.2	8.8	1712	2996	5.7	71	41
400/2	113	2660										
400/3LC	129	2660										
400/3	172	3990										
400/4LC	172	3548										
400/4	225	5320										
400/5LC	215	4435										
400/5	286	6650										
400/6LC	252	5322	Mag.+	6.0	7.0	8.4	9.4					
400/6	238	7980										
400/7LC	285	6210	Mag.+	6.0	7.0	8.4	9.4					
400/7	400	9310										
400/8LC	338	7096	Mag.+	6.0	7.0	8.4	9.4					
400/8	451	10640										
500/2LC	113	2360	Mag.	4.7	6.0	8.7	14.7	1308	2289	17	127	60
500/2	146	3540										
500/3LC	172	3540										
500/3	225	5310										
500/4LC	225	4720										
500/4	304	7080										
500/5LC	286	5900										
500/5	382	8850										
500/6LC	338	7080	Mag.+	10.7	12.0	13.4	16.8					
500/6	451	10620										
500/7LC	400	8260	Mag.+	10.7	12.0	13.4	16.8					
500/7	530	12390										
500/8LC	451	9440	Mag.+	10.7	12.0	13.4	16.8					
500/8	608	14160										

⁽¹⁾ The dynamic slipping torque range for a given brake model can be changed by switching the actuators in or out by means of the hand slide valves provided e.g. a 340/3 to a 340/2 or a 340/1.

⁽²⁾ The heat transfer ratings in the above chart assume a forward rotation of the brake disc. For reverse rotation the heat ratings of models Magnum 260 and Magnum 340 should be reduced by 15%. If in doubt please contact your Wichita engineer.

Magnum Brakes

Magnum

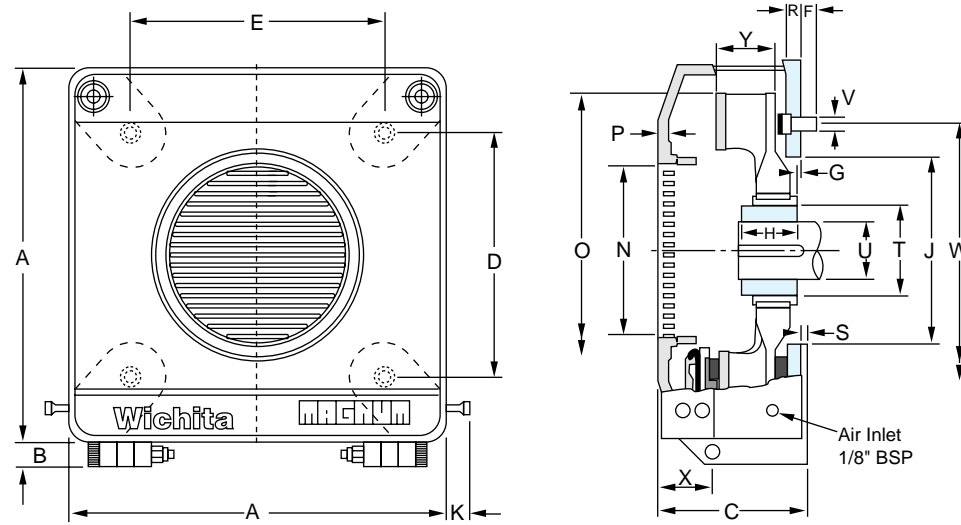

New!
Magnum B

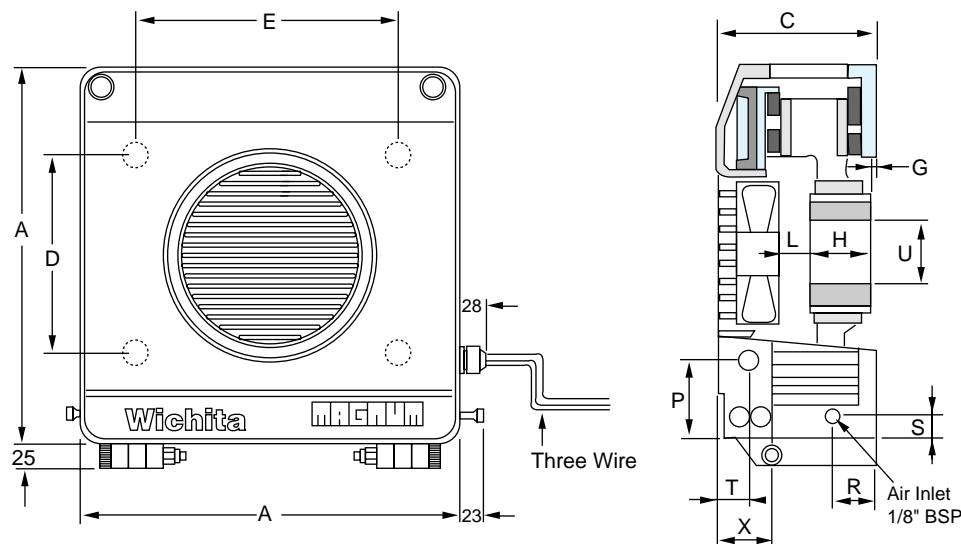

Magnum Plus

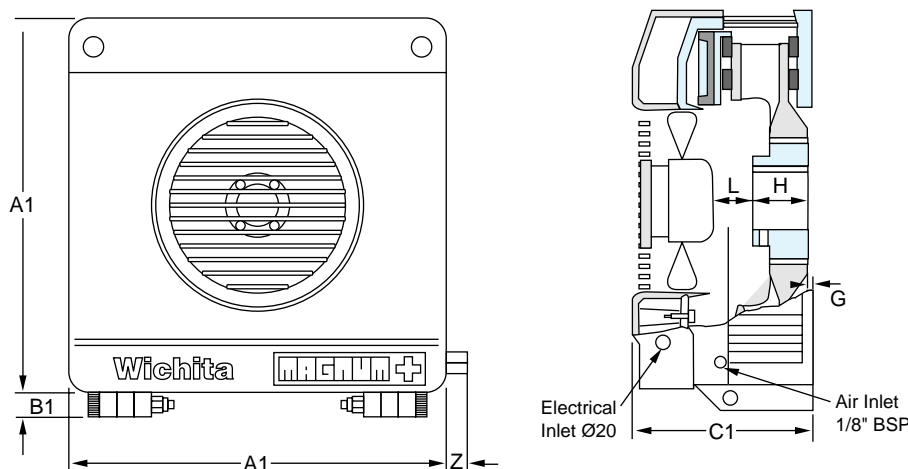

Dimensions (mm) (Consult factory for drawing before final layout.)

Model No.	A	A1	B	B1	C	C1	D	E	F	G	H	J	K
260	10.4 (264)	10.6 (270)	1.0 (25)	0.8 (20)	5.7 (145)	7.7 (195)	7.0 (176.8)	7.0 (176.8)	0.8 (20)	0.2 (5)	2.2 (55)	3.9 (100)	0.9 (23)
340	13.6 (346)	13.8 (350)	1.0 (25)	0.8 (20)	5.7 (145)	8.0 (205)	5.5 (140.0)	9.5 (242.5)	0.9 (22)	0.2 (5)	2.2 (55)	6.9 (175)	0.9 (23)
340 Thin	13.6 (346)	13.8 (350)	1.0 (25)	0.8 (20)	5.12 (130)	8.0 (205)	5.5 (140.0)	9.5 (242.5)	0.9 (22)	0.2 (5)	2.2 (55)	6.9 (175)	0.9 (23)
400	16 (406)	16.1 (410)	1.0 (25)	0.8 (20)	5.7 (145)	7.7 (195)	10.4 (265.2)	10.4 (265.2)	1.1 (27)	0.2 (5)	2.4 (60)	7.9 (200)	0.9 (23)
500	19.9 (506)	2.0 (510)	1.1 (28)	0.8 (20)	5.7 (150)	8.0 (205)	13.3 (339.4)	13.3 (339.4)	1.2 (30)	0.2 (5)	2.4 (60)	12.6 (320)	0.9 (23)

Model No.	L	N	O	P	R	S	U		V	W PCD	X	Y	Z	
							Min	Max						
260	2.0 (50)	3.7 (95)	9.0 (230)	.24 (6)	.59 (15)	.20 (5)	2.44 (62)	.59 (15)	1.77 (45)	4 off-M12 X 35	9.84 (250)	1.969 (50)	2.36 (60)	.47 (12)
340	2.0 (50)	5.5 (14)	11.0 (280)	.24 (6)	.51 (13)	.28 (7)	3.62 (92)	.98 (25)	2.24 (57)	4 off-M12 x 30	11.02 (280)	1.969 (50)	2.32 (59)	.47 (12)
340 Thin	2.0 (50)	5.5 (14)	11.0 (280)	.24 (6)	.51 (13)	.28 (7)	3.62 (92)	.98 (25)	2.24 (57)	4 off-M12 x 30	11.02 (280)	1.969 (50)	2.32 (59)	.47 (12)
400	1.0 (25)	7.9 (200)	13.4 (340)	.31 (8)	.51 (13)	.12 (3)	4.69 (119)	1.38 (35)	2.56 (65)	4 off-M16 x 40	14.76 (375)	2.047 (52)	2.36 (60)	.47 (12)
500	1.0 (25)	11.1 (283)	17.5 (445)	.44 (11)	.59 (15)	.08 (2)	5.6 (140)	1.38 (35)	4.08 (102)	4 off-M20 x 45	18.1 (480)	2.2 (55)	2.32 (59)	.47 (12)

Certified prints showing exact dimensions are sent with every order acknowledgement, and these should always be obtained before finalizing any design detail.

Note: For mounting, use socket head cap screws conforming to the ASTM-574-97a or ASTM-574M-97a (Metric Version).

Component Parts

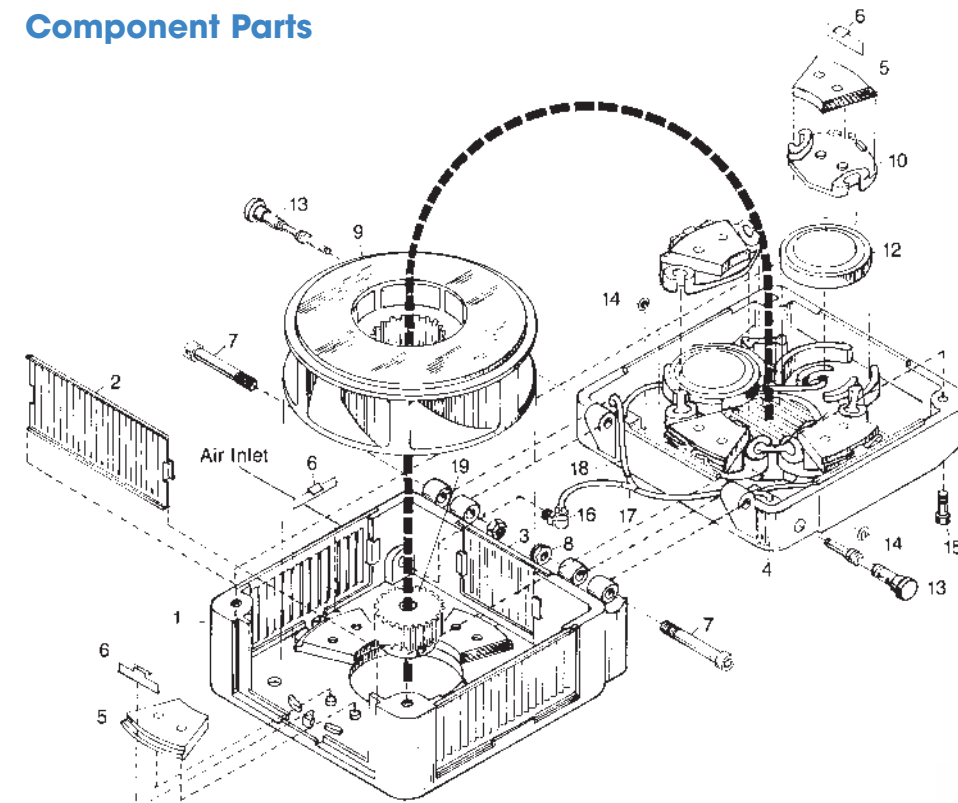

1. Back Casing
2. Side Guard
3. Side Guard
4. Front Casing
5. Friction Pad
6. Retaining Clip
7. Socket Head Bolt
8. Self-locking Nut
9. Brake Disc
10. Carrier Plate
12. Actuator Assembly
13. Air Valve
14. Retaining Ring
15. Socket Head Bolt
16. 90° Elbow
17. "Y" Connector
18. Air Hose
19. Hub

