

Industrial Clutch Products



MODEL LKM

Air Set Marine Clutches

LKM Clutch Design Features

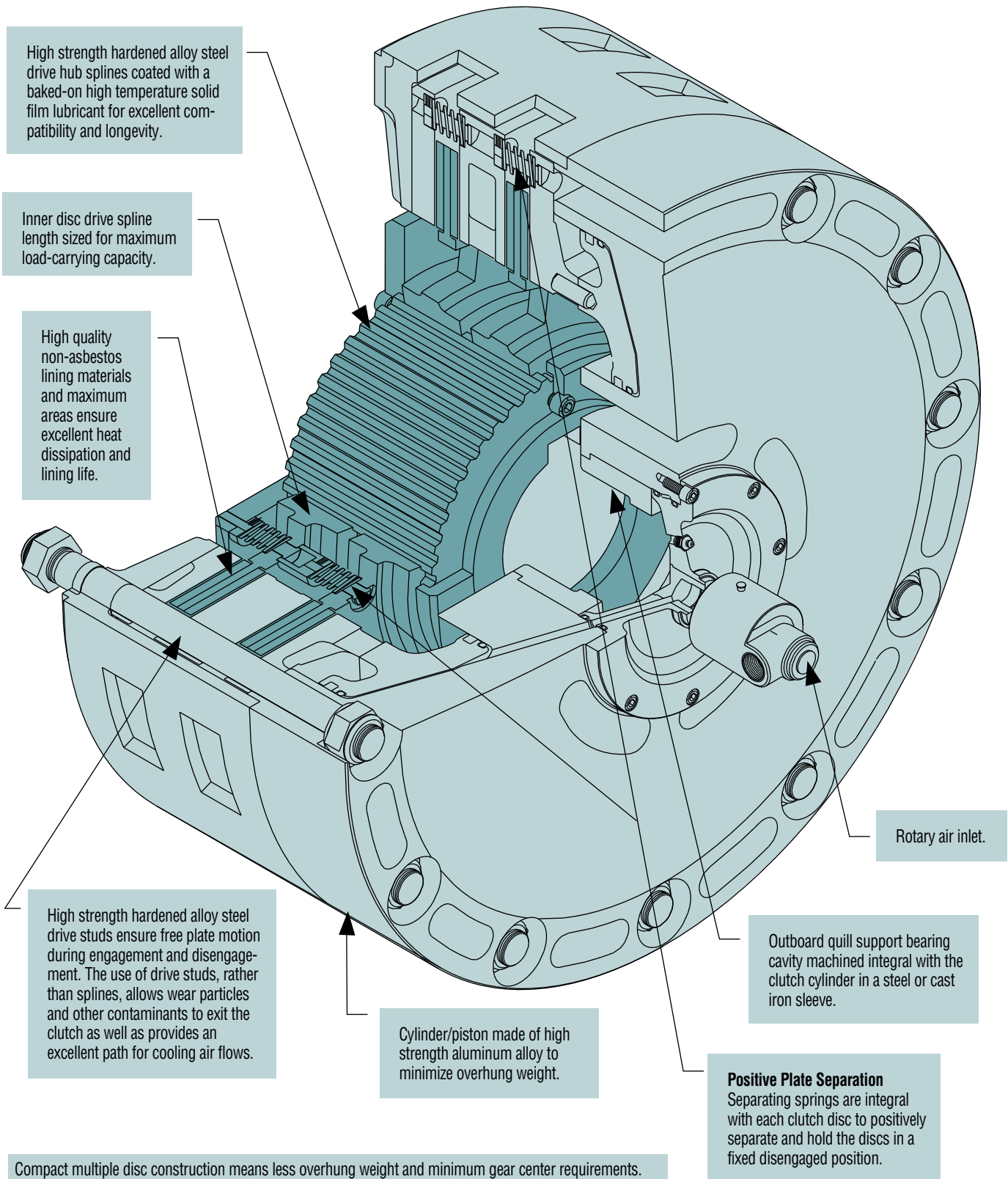

Compact multiple disc construction means less overhung weight and minimum gear center requirements.

Clutch designed with total attention given to maximizing ventilation for cool-running operation and the ability to perform high energy engagements with minimum temperature build-up.

Precision machining of all components ensures positive interchangeability of all mating parts.

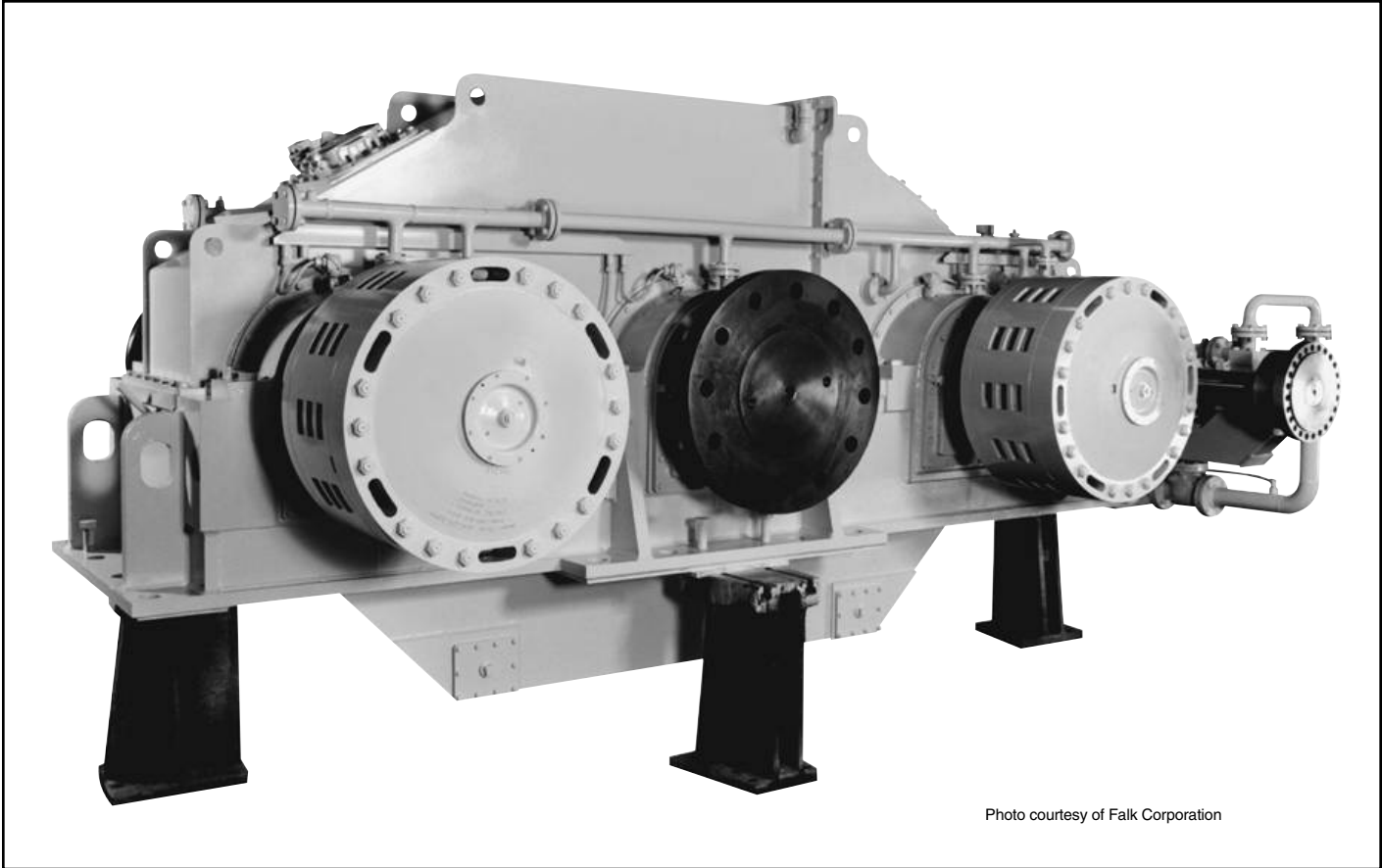

Photo courtesy of Falk Corporation

Model LKM-330-B clutches, each rated 5250 HP @ 500 RPM connect dual engine inputs to a single propeller on a Falk Model 55 x 20 DMA1-S marine gear.

LKM AIR SET MARINE CLUTCH DEVELOPMENT HISTORY

The Model LKM marine clutch incorporates many of the features found in our Model LK clutch series with some notable exceptions. Cyclic applications, where the LK style finds its most frequent use, contain duty cycles which bear little resemblance to marine main propulsion service. Marine clutches are required to make infrequent, yet in some instances, severe engagements from a heat standpoint. The clutches are also called upon to run for extended periods in the engaged position (ahead clutches) and for extended periods in the disengaged position (reverse clutches).

The Model LK clutches were rugged enough to handle the load duty cycle from a torque and heat standpoint but required modification to their separation systems in order to be suitable for marine service. Industrial Clutch Products was the first to recognize the importance of positive plate separation for marine service and **all** clutches installed in marine service contained this feature. Disc clutches for marine service without positive plate separation have experienced a sad approval rating from users.

This is particularly true in forward/reverse service where, strangely enough, the unloaded reverse clutch gives the greatest degree of trouble. Because of the gearing arrangement, the outer members of this clutch rotate in one direction while the

inner member rotates in the other. This gives rise to the term “twice relative rotation.” The cant of the gear to which these clutches are mounted in order to align with the propeller shaft as well as vessel motion due to wave action causes the clutch plates, if not positively separated, to kiss and wear or burn-out. Exactly the same result would occur if one were going down the road in an automobile at a high rate of speed with the brake pedal lightly depressed.

To eliminate this, Industrial Clutch Products designed and patented **positive plate separation** which has accrued over 30 years of field experience in marine main propulsion service. The separating system is self-adjusting for wear and no adjustments are ever required by the user during regular use or during routine maintenance. No plate contact can occur with this unique positive plate separation system and the many advantages of the disc clutch can be fully realized for marine service.

The incorporation of positive plate separation, a bearing cavity for the outboard quill bearing, and modifications made to increase the load carrying capacity on a continual basis changed the time-proven LK design into the Model LKM marine clutch.

Model LKM

DOUBLE DISK LKM CLUTCH

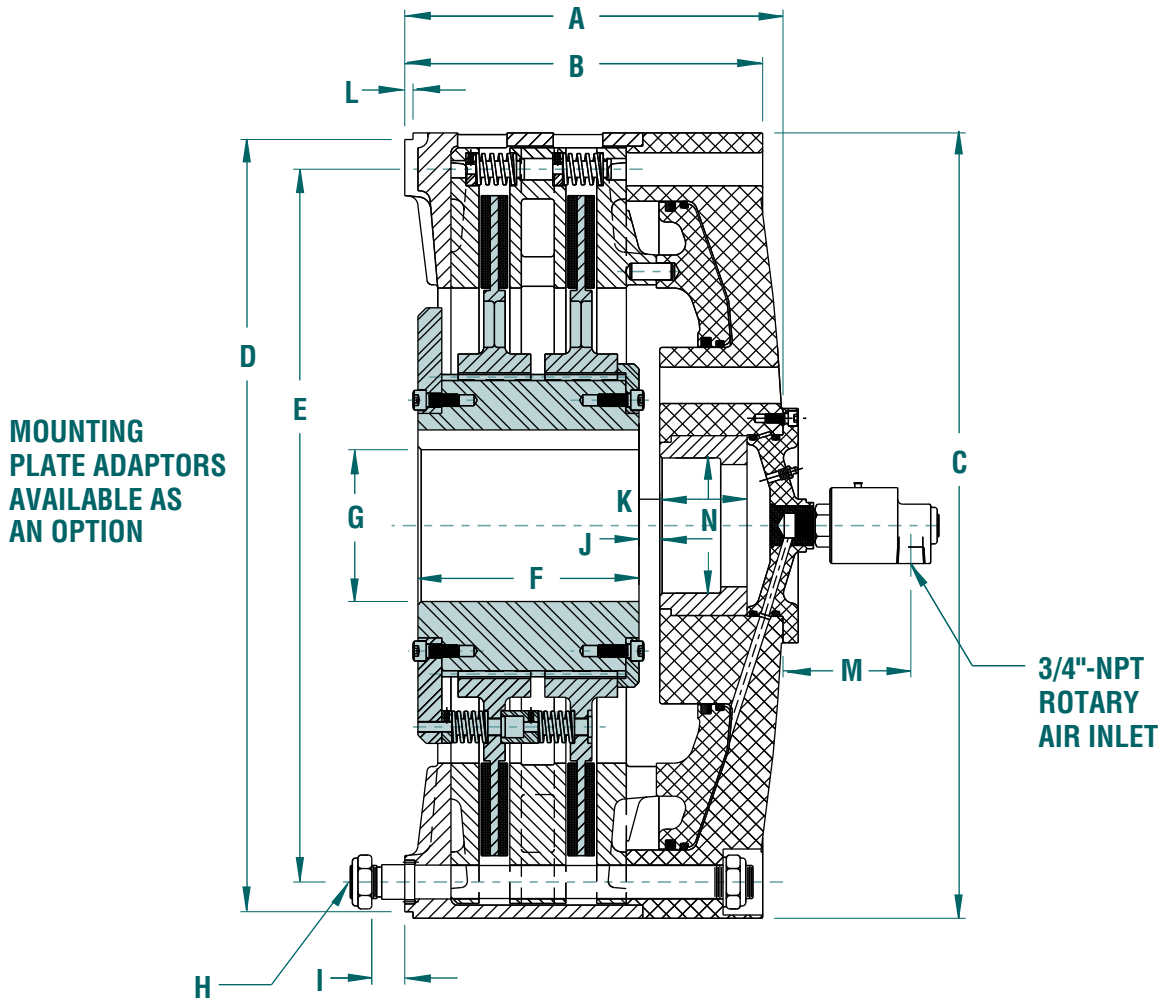

DIMENSIONAL DATA

All dimensions in inches

LKM Model	A	B	C	D	E	F	G Min.-Max.	H No.-Size	I	J	K	L	M	N Min.-Max.
LKM-213	8.69	7.86	16.63	16.25	14.65	5.25	2-7/8 - 3-1/2	8-15/16	1	.44	1.50	.18	4	3-1/2 - 4-3/8
LKM-313	10.50	9.69	16.63	16.25	14.63	7.06	2-7/8 - 3-1/2	8-15/16	1	.44	1.50	.18	4	3-1/2 - 4-3/8
LKM-218	11.31	10.31	22.63	21.50	20.00	7.75	2-7/8 - 4-1/8	12 - 1-1/16	1	.56	1.38	.18	4	4-1/2 - 5-9/16
LKM-318	14.19	13.19	22.63	21.50	20.00	10.63	2-7/8 - 4-1/8	12 - 1-1/16	1	.56	1.38	.18	4	4-1/2 - 5-9/16
LKM-221	11.06	10.44	25.00	24.50	22.50	6.81	3-3/8 - 5-1/2	12 - 1-1/16	1	.31	2.19	.18	4	4-1/2 - 5-15/16
LKM-321	13.63	13.00	25.00	24.50	22.50	9.38	3-3/8 - 5-1/2	12 - 1-1/16	1	.31	2.19	.18	4	4-1/2 - 5-15/16
LKM-225	14.38	13.63	29.75	29.25	27.00	8.50	4-5/8 - 7-1/2	12 - 1-5/16	1-1/4	.78	3.31	.18	4	4-1/2 - 6
LKM-325	17.63	16.86	29.75	29.25	27.00	11.75	4-5/8 - 7-1/2	12 - 1-5/16	1-1/4	.78	3.31	.18	4	4-1/2 - 6
LKM-230	15.63	13.25	35.50	35.00	32.00	9.00	5-1/4 - 9-5/8	12 - 1-1/4	2	1.06	3.06	.25	4-5/8	5 - 8
LKM-330	18.94	16.56	35.50	35.00	32.00	12.25	5-1/4 - 9-5/8	12 - 1-1/4	2	1.06	3.06	.25	4-5/8	5 - 8
LKM-235	15.63	13.38	41.50	40.75	36.88	7.69	8 - 12	24 - 1-1/4	2	1.13	3.88	.25	3-7/8	6 - 9-1/16
LKM-335	18.06	15.81	41.50	40.75	36.88	10.13	8 - 12	24 - 1-1/4	2	1.13	3.88	.25	3-7/8	6 - 9-1/16
LKM-242	18.27	16.58	48.75	48.00	44.00	10.75	8 - 12	24 - 1-3/4	3	1.00	4.00	.25	3-7/8	6-1/2 - 9-1/16
LKM-342	22.13	20.44	48.75	48.00	44.00	14.63	8 - 12	24 - 1-3/4	3	1.00	4.00	.25	3-7/8	6-1/2 - 9-1/16
LKM-248	21.02	18.77	54.75	54.00	50.00	11.56	9-1/8 - 14	24 - 1-3/4	3	1.38	5.00	.25	2-3/4	10 - 14.50
LKM-348	25.50	23.25	54.75	54.00	50.00	16.00	9-1/8 - 14	24 - 1-3/4	3	1.38	5.00	.25	2-3/4	10 - 14.50

- NOTES: 1.) Use certified drawing dimensions only for final layouts.
 2.) DXF and IGES files available upon request.
 3.) Dimensions subject to change without notice.
 4.) Consult factory or refer to application information when selecting units.

OPERATIONAL DATA

LKM Model	Static Torque @ 125 PSIG (lb.-in.)	Dynamic Torque @ 125 PSIG (lb.-in.)	Weight Outer (lbs.)	Weight Inner (lbs.)	Total Weight (lbs.)	WR ² Outer (lb.-ft. ²)	WR ² Inner (lb.-ft. ²)	Maximum Speed (RPM)
LKM-213	94,600	82,000	155	65	220	50	7	2100
LKM-313	142,000	123,000	220	90	310	70	9	2100
LKM-218	200,000	173,333	440	135	575	255	24	1600
LKM-318	300,000	260,000	480	200	680	284	35	1600
LKM-221	382,000	331,000	430	200	630	320	50	1400
LKM-321	572,000	445,733	525	285	810	396	71	1400
LKM-225	510,000	442,000	730	360	1,090	775	110	1200
LKM-325	765,000	663,000	850	451	1,301	836	158	1200
LKM-230	1,000,000	866,666	1,095	475	1,570	1,456	222	1000
LKM-330	1,500,000	1,300,000	1,290	710	2,000	1,894	320	1000
LKM-235	1,455,000	1,261,000	1,925	675	2,600	3,091	472	850
LKM-335	2,183,000	1,892,000	2,088	1,012	3,100	4,580	720	850
LKM-242	2,716,000	2,354,000	2,770	1,098	3,868	7,495	990	700
LKM-342	4,074,600	3,531,320	3,305	1,565	4,870	9,148	1,458	700
LKM-248	2,466,600	3,004,386	3,942	1,535	5,477	13,048	1,752	650
LKM-348	5,200,000	4,506,666	4,721	2,205	6,926	15,989	2,584	650

SELECTION CHART – MARINE ENGINE HORSEPOWER (S.F. 2.0 @ 125 PSIG)

Clutch RPM	250	500	750	1000	1250	1500	1750	2000	2500	3000	3500	4000	4500	5000	6000	7000	8000	9000	10000	12000	14000	16000	18000	20000	Clutch RPM	
150	318	321 225	325 230	230	330 235	330 235	330	335 242	335 242	242	342 248	342 248	342	348	348	-	-	-	-	-	-	-	-	-	-	150
200	218	221	321 225	325 230	230	230	330 225	330 225	335 242	335 242	242	242	342 248	342 248	348	348	348	-	-	-	-	-	-	-	-	200
250	313 218	318 221	221	321	325 230	325 230	230	330 225	330 225	335 242	335 242	335 242	242	242	342 248	342	342	348	348	-	-	-	-	-	-	250
300	313 218	318 221	221	321 225	321	325 230	230	330 235	330 235	330	330 242	335 242	335 242	335 242	242	342 248	342 248	342	348	348	-	-	-	-	-	300
350	313 218	218	318 221	221	321 225	321	325 230	325 230	230	330 235	330 235	330 235	335 242	335 242	335 242	242	342 248	342 248	342	342	348	-	-	-	-	350
400	213	218	318 221	221	321 225	321 225	321	325 230	230	230	330 235	330 235	330 235	335 242	335 242	242	342 248	342 248	342	342	348	348	-	-	-	400
450	213	313 218	318 221	318 221	221	321 225	321 225	321	325 230	230	230	330 235	330 235	330 235	335 242	335 242	242	242	342 248	342 248	342	348	348	-	-	450
500	213	313 218	218	318 221	221	221	321 225	321 225	325 230	230	230	330 235	330 235	330 235	335 242	335 242	242	242	342 248	342 248	342	342	348	348	348	500
550	213	313 218	218	318 221	318 221	221	321 225	321 225	321	325 230	230	230	330 235	330 235	330 235	335 242	335 242	242	242	342 248	342 248	342	348	348	348	550
600	213	313 218	218	318 221	318 221	221	221	321 225	321 225	325 230	325 230	230	230	330 235	330 235	330	335 242	335 242	335 242	242	342 248	342 248	342	348	348	600
650	213	313 218	218	318 221	318 221	221	221	321 225	321 225	325 230	230	230	230	230	330 235	330 235	335 242	335 242	335 242	242	342 248	342 248	342	342	342	650
700	213	213	313 218	218	318 221	318 221	221	221	321 225	321	325 230	325 230	230	230	330 235	330 235	330 235	335 242	335 242	335 242	242	242	342	342	342	700
750	213	213	313 218	218	318 221	318 221	221	221	321 225	321 225	325 230	325 230	230	230	330 235	330 235	335	335	335	335	-	-	-	-	-	750
800	213	213	313 218	218	318 221	318 221	221	221	321 225	321 225	321	325 230	325 230	230	230	330 235	330 235	330 235	335	335	-	-	-	-	-	800
850	213	213	313 218	218	318 221	318 221	221	221	321 225	321	325 230	325 230	230	230	330 235	330 235	330 235	330	-	-	-	-	-	-	-	850
900	213	213	313 218	313 218	218	318 221	318 221	221	321 225	321 225	321	325 230	325 230	230	230	330	330	330	330	330	-	-	-	-	-	900
1000	213	213	213	313 218	218	218	318 221	318 221	221	221	321 225	321 225	321	325 230	325 230	230	-	-	-	-	-	-	-	-	-	1000
1100	213	213	213	313 218	218	218	318 221	318 221	221	221	321 225	321 225	321	321	325	-	-	-	-	-	-	-	-	-	-	1100
1200	213	213	213	313 218	313 218	218	218	318 221	318 221	318 221	221	321 225	321 225	321	325	325	-	-	-	-	-	-	-	-	-	1200
1400	213	213	213	213	313 218	313 218	218	218	318 221	318 221	221	221	321	321	321	-	-	-	-	-	-	-	-	-	-	1400
1600	213	213	213	213	313 218	313 218	313 218	218	218	318	318	-	-	-	-	-	-	-	-	-	-	-	-	-	-	1600
1800	213	213	213	213	213	313	313	313	-	-	-	-	-	-	-	-	-	-	-	-	-	-	-	-	-	1800
2000	213	213	213	213	213	213	313	313	-	-	-	-	-	-	-	-	-	-	-	-	-	-	-	-	-	2000

LKM MARINE CLUTCH APPLICATION INFORMATION

The selection chart on the previous page is suitable for forward/reverse main propulsion service at 125 PSI actuation.

For controllable pitch propellers, dredge pumps, winches, and fire pumps use the following service factors.

Machinery	Service Factor
Main Propulsion Cont. Pitch Prop.	1.8
Winches, Centrifugal Fire Pumps	1.65
Centrifugal Dredge Pumps	2.5
Main Propulsion Continuous Slip from Engine Idle	Consult Factory

Example: CENTRIFUGAL DREDGE PUMP DISCONNECT CLUTCH APPLICATION.

Input Parameters

The engine is rated 3000 HP and the shaft the clutch is to be mounted on is rotating at 900 RPM. The available air pressure is 150 PSIG.

$$\text{Working Torque} = \frac{\text{HP} \times 63025}{\text{RPM}} = \frac{3000 \times 63025}{900} = 210083 \text{ LBIN}$$

$$\begin{aligned} \text{Minimum Static Torque} &= \text{Work Torque} \times \text{Service Factor} \\ &= 210083 \times 2.5 = 525208 \text{ LBIN} \end{aligned}$$

$$\text{Minimum Catalogue Rating} = \text{Static Torque Req'd} \times \frac{\text{Rated Press}}{\text{Supply Press}}$$

$$\text{Minimum Catalogue Rating} = 525208 \times \frac{125}{150} = 437674 \text{ LBIN}$$

The Model LKM-225-B (rated at 510,000 LB-IN) is selected from the static torque column shown in the operational data chart on the previous page. This unit is the nearest size that meets or exceeds the value of 437,674 LB-IN required.

The allowable speed for the Model LKM-225-B is 1200 RPM and exceeds the operating speed of 900 RPM. The selection is appropriate from a torque and speed standpoint.

Dredge pumps can draw extraneous matter into the pump which may suddenly stall the pump impeller. This places a huge shock on the drive system and the clutch is called upon to act as a fuse in these instances. A review of the magnitude of the actual applied service factor is *always* required to be certain the drive system components can withstand these overloads. It may be necessary to reduce the clutch service factor which increases the likelihood of clutch damage but saves a more costly drive system repair.

The preferred way to reduce the service factor is to adjust the operating air pressure accordingly and maintain the clutch size as originally selected.

The following procedure may be used to calculate the air pressure required for any desired service factor. In this example, the recommended service factor was 2.5. We selected a Model LKM-225-B clutch since it was the closest unit that met or exceeded the calculated torque requirement of 437,674 LB-IN. Note that the actual service factor is 2.91.

$$\text{Tact} = \text{Actual Static Capacity} = \text{Cat. Stat. Rating} \times \frac{\text{Supply Press}}{\text{Rated Press}}$$

$$\text{Tact} = 510000 \times \frac{150}{125} = 612000 \text{ LBIN}$$

$$\text{Actual Serv. Fact.} = \frac{\text{Tact}}{\text{Working Torq}} = \frac{612000}{210083} = 2.91$$

If, by way of example, it was decided that a service factor of 2.0 was required, the supply air pressure should be set at 103 PSI.

$$\text{Operating Pressure} = \frac{125 \times \text{Req'd. Serv. Fact.} \times \text{Work Torq}}{\text{Cat. Stat. Torq. Rating}}$$

$$\text{Operating Pressure} = \frac{125 \times 2.0 \times 210083}{510000} = 103 \text{ PSIG}$$

To summarize, a Model LKM-225-B operating at 103 PSIG will provide a 2.0 service factor for this application.

Distribuidor Autorizado e Importador - Arten Freios e Embreagens Ltda.

Fone: (11) 5594-8333 • Fax (11) 5589-2422 - arten@arten.com.br • www.arten.com.br