

Spring-Set Air Release Brakes

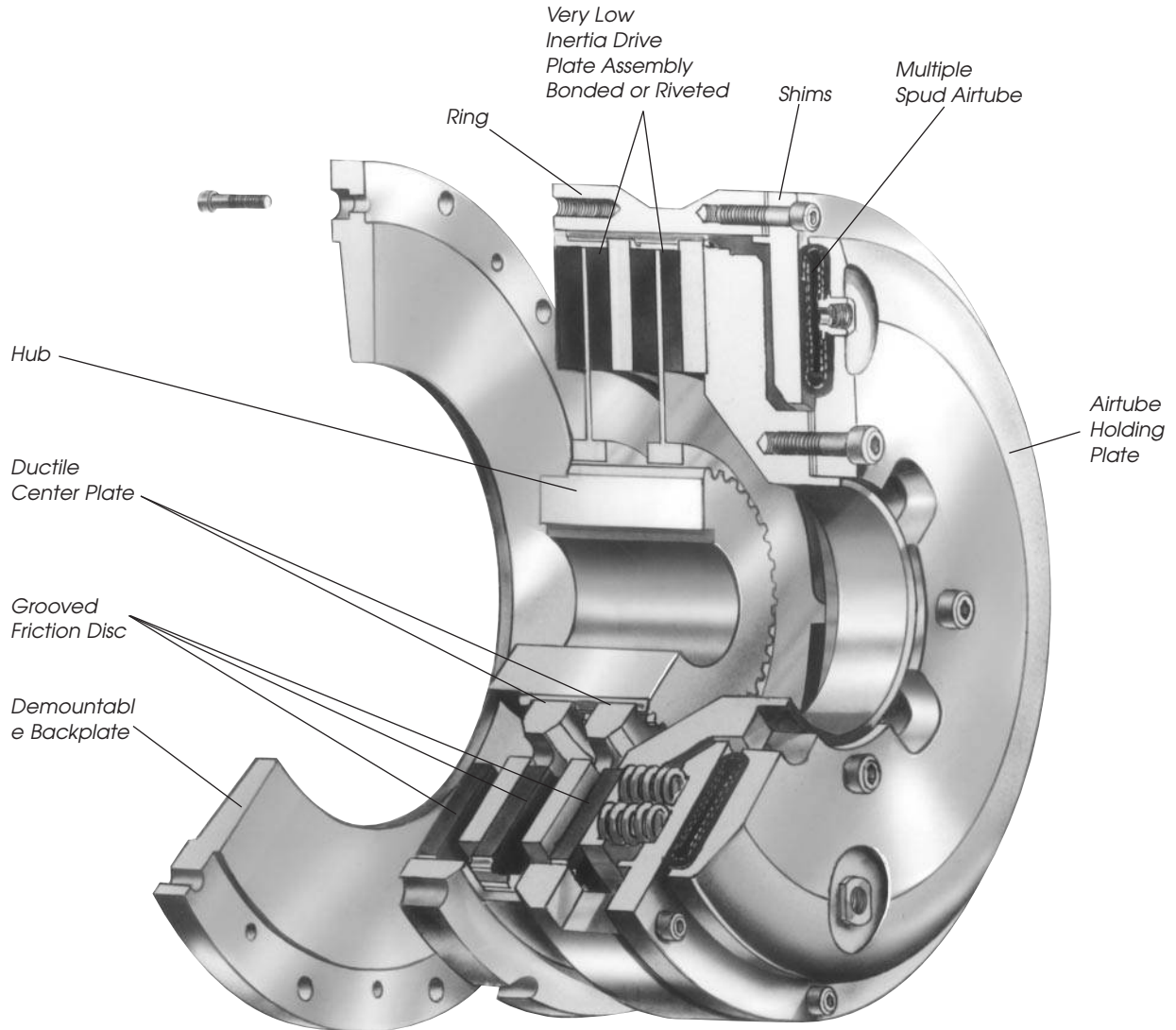

Wichita Spring-Set Air Release Brakes are ideal for fail safe protection of process equipment. Constructed of high strength cast iron, this improved design has thick friction discs for longer wear life. The fast acting air-tube design assures quick, smooth stops.

- No lubrication
- No adjustment
- Available in vertical mount
- Quick, simple installation
- Explosion proof design

Selection requirements

The selection of a Low Inertia Brake is based on:

1. Torque required to stop a load.
2. Friction area necessary to absorb rotational energy.
3. Contact velocity of rotating discs.
4. Maximum bore capacity of unit.

Selection

Low Inertia Spring-Set Brake

To properly select a brake, the total rotating inertia, WR^2 , must be reflected to the brakeshaft.

Application Data:

Refer to page 43, except, cyclic operation—7 rpm, and 218 Very Low Inertia Clutch.

Alternate Shaft WR^2 referred to clutch shaft =

$$(\text{Alternate Shaft } WR^2) \left(\frac{\text{Alternate Shaft rpm}}{\text{Clutch Brake Shaft rpm}} \right)^2$$

WR^2 referred to clutch-brake shaft

$$= (39,091) \left(\frac{30}{204} \right)^2$$

WR^2 referred to clutch-brake shaft

$$= 845.4 \text{ lb.ft.}^2 @ 204 \text{ rpm}$$

$$\text{Crank Shaft } WR^2 = 845.4 \text{ lb.ft.}^2$$

$$\text{Clutch-Brake Shaft } WR^2 = 78.2 \text{ lb.ft.}^2$$

$$\begin{aligned} \text{Clutch Hub and Drive Plate } WR^2 \\ \text{from Specification Table} = 14.7 \text{ lb.ft.}^2 \\ \text{(page 57)} \end{aligned}$$

$$\text{Est. Brake } WR^2 = \frac{14.7 \text{ lb.ft.}^2}{}$$

$$\text{Est. Total } WR^2 = 953.0 \text{ lb.ft.}^2$$

Brake Selection:

Stopping angle of crank shaft

$$= 120^\circ = \varnothing_b \text{ Use } 90^\circ \text{ for calculation}$$

Estimated time to stop:

$$t = \left(\frac{\varnothing_b}{360^\circ} \right) \left(\frac{60}{\text{crank shaft rpm}} \right)$$

$$= \left(\frac{90}{360} \right) \left(\frac{60}{30} \right) = .5 \text{ sec.}$$

Deceleration Torque

$$= (12) \left(\frac{WR^2}{32.2} \right) \left(\frac{\text{clutch-brake rpm}}{(9.5) (t)} \right)$$

$$= (12) \left(\frac{953}{32.2} \right) \left(\frac{204}{(9.5) (.5)} \right)$$

$$= 15,250 \text{ lb.in.}$$

HP/100 rpm

$$= \frac{15,250}{630} = 24 \text{ HP/100 rpm}$$

From duty chart (page 31) "Group B" for spring set brake (SS):

214 SS Brake is rated @ 28 HP/100 rpm
90% torque rating = 24,800 lb.in.

WR^2 of 214 SS VLI Brake = 4.5 lb.ft.², therefore deceleration torque calculation is correct.

*Average heat horsepower to clutch & brake.

$$\text{Ave. heat HP} = \frac{(\text{Total } WR^2) (\text{rpm}^2) (\text{cpm})}{1.9 \times 10^8}$$

$$= \frac{(953) (41,616) (7)}{1.9 \times 10^8} = 1.45 \text{ HP}$$

*Check with factory for heat capacity.

Note:

This application example is for preliminary sizing only. Contact a Wichita Sales Engineer or the factory for final selection.

Spring-Set Air Release Brakes

- (1) For high speed cyclic duty
- (2) Slow speed cyclic duty
- (3) Holding and service brakes

Specifications

Model Size ATD-	Slip Torque Lb. In. .3 CF* Minimum Air-Tube Pressure PSI For Released Brake		
	60 (1)	75(2)	90 (3)
106	2,225	2,900	3,700
206	4,300	5,600	7,200
108	3,700	4,800	6,200
208	7,100	9,100	12,000
111	8,200	10,500	11,600
211	15,600	20,000	26,000
114	14,500	18,600	24,700
214	27,600	35,400	46,300
118	31,400	40,400	51,600
218	60,000	77,000	100,000
124H	75,500	111,000	—
224H	137,000	216,000	—
130H	162,200	211,700	260,500
230H	310,000	404,500	495,500
136	254,500	300,000	400,000
236	477,500	564,000	760,000
142	425,000	—	—
242	796,000	—	—
148	698,250	—	—
248	1,335,000	—	—
260	3,255,000	—	—
360	4,921,000	—	—

* Max. recommended air pressure – 130 PSI

Model No.	
Model Size	Model Type
ATD-xxx	LI-SSB for Low Inertia Spring Set Brake
ATD-xxx	VLI-SSB for Very Low Inertia Spring Set Brake

Model Size ATD-	Swept Friction Area In ²	Max. Bore Rect. Key Inches	Air Volume-Inches ³		Recommended Clearances Inches
			New Linings	Worn Linings	
106	39	2	5	12	1/16-3/32
206	78	2	6	12	1/16-3/32
108	56	2-3/8	6	18	1/16-1/8
208	112	2-3/8	7	18	3/32-5/32
111	114	2-5/8	10	30	1/16-1/8
211	228	2-5/8	12	30	3/32-5/32
114	158	4-1/8	15	45	1/16-1/8
214	316	4-1/8	18	45	3/32-5/32
118	264	5-1/4	26	80	1/16-1/8
218	528	5-1/4	30	80	3/32-5/32
124H	574	7	60	165	3/32-5/32
224H	1,148	7	70	165	1/8-3/16
130H	827	8-1/2	100	240	3/32-5/32
230H	1,654	8-1/2	125	240	1/8-3/16
136	1,150	10-1/2	150	375	3/32-5/32
236	2,300	10-1/2	170	375	1/8-3/16
142	1,400	14	180	525	1/8-3/16
242	2,800	14	200	525	5/32-7/32
148	2,010	18	380	925	1/8-3/16
248	4,020	18	450	925	5/32-7/32
260	7,230	19	625	1750	3/16-5/16
360	10,845	19	750	1750	1/4-3/8

Note: Very Low Spring Set Brakes are available in sizes from ATD-108 to ATD-224H.



***Do Not Exceed 90% Of Slip Torque Ratings —
Maximum Horsepower Per 100 RPM Release Pressure - PSI**

Model Size ATD-	60 Duty				75 Duty				100 Duty			
	A	B	C	D	A	B	C	D	A	B	C	D
106	3	2.3	1.2	.6	4	3	1.5	.8	5	3.8	2	1
206	6	4.4	2.3	1.1	8	5.7	3	1.5	10	7.4	3.9	2
108	5.3	3.8	2	1	7	5	2.6	1.3	9	6.3	3.3	1.6
208	10	7.3	3.8	2	13	9.3	5	2.5	17	12.3	6.5	3.2
111	11.7	8.4	4.4	2.2	15	10.7	5.7	2.8	16.6	12	6.3	3.1
211	22	16	8.4	4.2	28.6	20.5	11	5.4	37	26	14	7
114	20	15	8	4	26.6	19	10	5	35	25	13	6.7
214	39	28	15	7.5	50	36	19	9.5	66	47	25	12.5
118	45	32	17	8.5	58	41	22	11	74	53	28	14
218	86	61	32	16	110	79	41	21	143	102	54	27
124H	108	77	41	20	158	114	60	30	183	131	69	34
224H	196	140	74	37	308	222	117	58	346	248	131	65
130H	232	166	88	44	303	217	115	57	372	267	141	70
230H	443	318	167	84	578	415	218	110	710	508	268	134
136	363	260	137	68	660	475	250	125	—	—	—	—
236	560	400	210	105	1050	755	400	200	—	—	—	—
142	610	435	230	115	—	—	—	—	—	—	—	—
242	1140	815	430	215	—	—	—	—	—	—	—	—
148	1000	715	375	190	—	—	—	—	—	—	—	—
248	1910	1370	720	360	—	—	—	—	—	—	—	—
260	4650	2340	1760	880	—	—	—	—	—	—	—	—
360	7030	4050	2660	1330	—	—	—	—	—	—	—	—

Model Size ATD-	Low Inertia Spring Set				Very Low Inertia Spring Set			
	Total Wt. Lbs.	HUB & CP Wt. Lbs.	HUB & CP WR ² #Ft. ²	Effec. Wt.† Lbs.	Total Wt. Lbs.	HUB & DP Wt. Lbs.	HUB & DP WR ² #Ft. ²	Effec. Wt.† Lbs.
106	36.5	6.40	.24	14.0	—	—	—	—
206	49.5	12.17	.46	18.34	—	—	—	—
108	63.23	10.0	.55	26.78	59.14	6.7	.24	16.53
208	81.5	16.0	.72	32.03	77.16	12.9	.44	24.06
111	96.96	15.0	1.35	40.75	97.55	9.6	.59	47.55
211	136.0	30.0	2.60	59.05	133.3	18.6	1.15	66.35
114	157.6	38	5.6	72.3	156.6	20.4	2.25	77.3
214	209.6	65	11	95.3	211.6	39.8	4.44	105.3
118	322	71	14.5	168	316.4	40.0	7.7	147
218	444	113	27.6	215	420.6	75.0	14.7	233
124H	690	131	50	377	657.5	84.0	28.5	365
224H	874	260	101	482	818	150	54.9	459
130H	1089	212	129	630	—	—	—	—
230H	1450	402	244	849	—	—	—	—
136	1814	351	325	1127	—	—	—	—
236	2780	784	705	1444	—	—	—	—
142	2994	680	705	1389	—	—	—	—
242	3601	1197	1385	1784	—	—	—	—
148	5070	1101	1785	2740	—	—	—	—
248	6501	1942	3335	3426	—	—	—	—
260	11549	2567	7077	5836	—	—	—	—
360	13739	3870	10615	6318	—	—	—	—

† Weight of internal clutch parts for use in calculating clutch engagement time.

Spring-Set Air Release Brakes

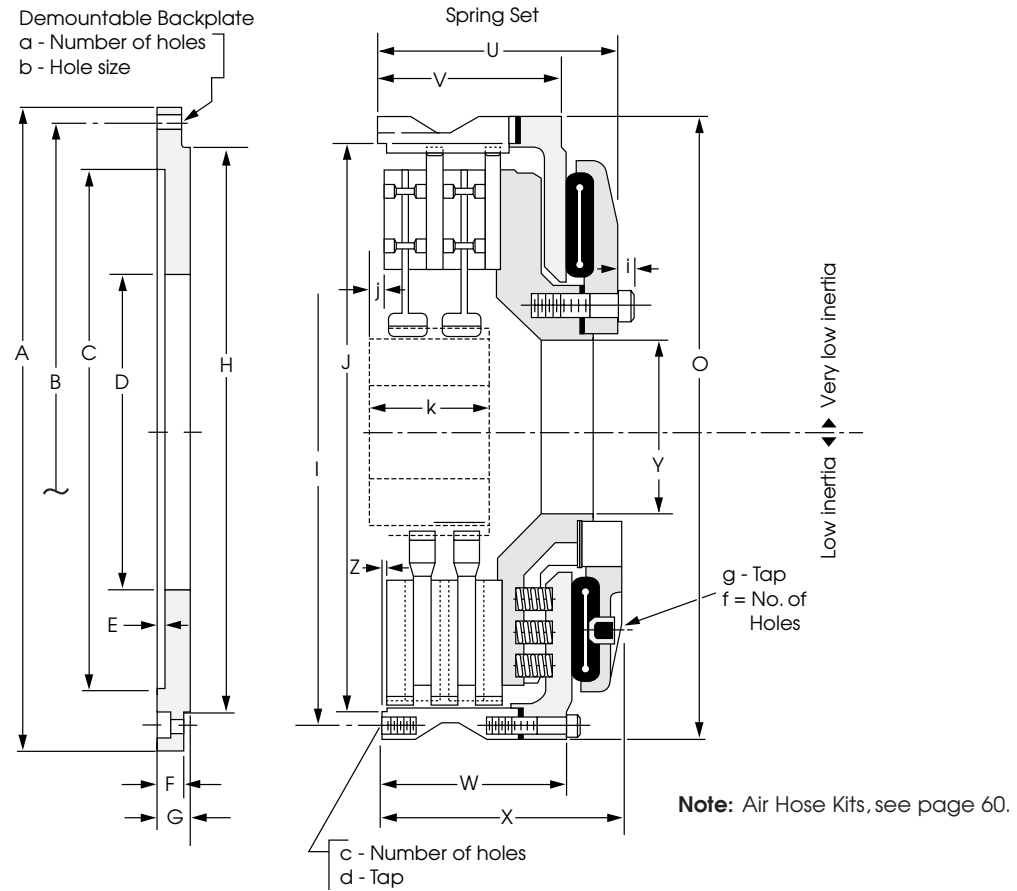

Dimensions

(Consult factory for drawing before final layout.)

Model No. ATD-	A	B	C	D	E	F	G	H	I	J	O	U
106	8.75	8.000	7.377/7.379	4.19	.06	.562	.69	7.373/7.375	8.000	7.377/7.379	8.81	—
206	8.75	8.000	7.377/7.379	4.19	.06	.562	.69	7.373/7.375	8.000	7.377/7.379	8.81	—
108	12.12	11.125	8.375/8.378	5.38	.25	.875	1.00	9.281/9.284	10.187	9.285/9.288	11.13	5.06
208	12.12	11.125	8.375/8.378	5.38	.25	.875	1.00	9.281/9.284	10.187	9.285/9.288	11.13	6.31
111	16.00	14.750	11.375/11.378	7.00	.38	1.125	1.25	12.370/12.373	13.500	12.375/12.378	14.75	5.00
211	16.00	14.750	11.375/11.378	7.00	.38	1.125	1.25	12.370/12.373	13.500	12.375/12.378	14.75	7.06
114	18.75	17.500	14.375/14.378	9.43	.38	1.125	1.25	15.121/15.124	16.250	15.125/15.128	17.50	6.81
214	18.75	17.500	14.375/14.378	9.43	.38	1.125	1.25	15.121/15.124	16.250	15.125/15.128	17.50	8.69
118	23.25	22.000	18.250/18.253	12.50	.38	1.125	1.25	19.495/19.498	20.750	19.500/19.503	22.00	7.44
218	23.25	22.000	18.250/18.253	12.50	.38	1.125	1.25	19.495/19.498	20.750	19.500/19.503	22.00	9.69
124H	30.00	28.750	24.375/24.378	14.50	.25	1.125	1.25	25.497/25.499	26.750	25.500/25.503	29.00	8.38
224H	30.00	28.750	24.375/24.378	14.50	.25	1.125	1.25	25.497/25.499	26.750	25.500/25.503	29.00	10.93
130H	37.00	35.500	30.375/30.378	19.25	.25	1.250	1.43	32.118/32.123	33.250	32.125/32.128	34.75	—
230H	37.00	35.500	30.375/30.378	19.25	.25	1.250	1.43	32.118/32.123	33.250	32.125/32.128	34.75	—
136	43.50	42.000	36.375/36.378	23.63	.25	1.500	1.75	38.120/38.123	39.500	38.125/38.128	41.00	—
236	43.50	42.000	36.375/36.378	23.63	.25	1.500	1.75	38.120/38.123	39.500	38.125/38.128	41.00	—
142	52.00	49.250	44.625/44.628	29.50	.25	1.500	1.75	44.995/44.998	46.500	45.000/45.003	49.00	—
242	52.00	49.250	44.625/44.628	29.50	.25	1.500	1.75	44.995/44.998	46.500	45.000/45.003	49.00	—
148	61.00	58.000	52.000/52.005	32.00	.25	1.500	1.75	51.993/51.998	54.000	52.000/52.005	56.75	—
248	61.00	58.000	52.000/52.005	32.00	.25	1.500	1.75	51.993/51.998	54.000	52.000/52.005	56.75	—
260	—	—	62.750/62.760	36.00	.25	—	—	62.740/62.745	66.500	62.750/62.760	70.50	—
360	—	—	62.750/62.760	36.00	.25	—	—	62.740/62.745	66.500	62.750/62.760	70.50	—

Notes: Very Low Inertia Spring Set Brakes are available in sizes from ATD-108 to ATD-224H. See page 34.
For mounting, use socket head cap screws conforming to the ASTM-574-97a.

Component Parts

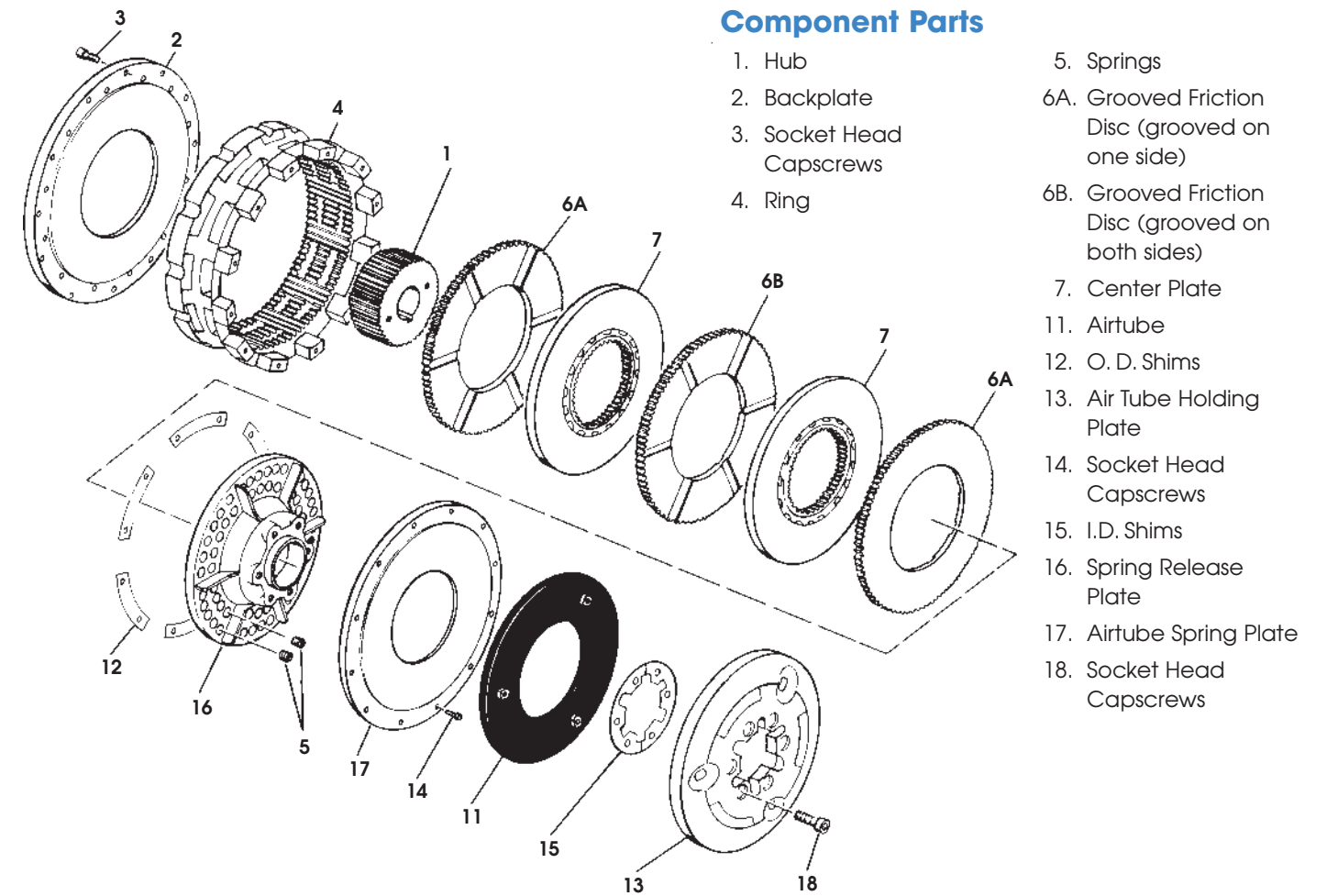

Model No. ATD-	V	W	X	Y	Z	a	b	c	d	f	g	j	k
106	—	3.56	4.88	2.00	.06	4	11/32	4	5/16-18	2	1/4"NPT	.69	2.00
206	—	4.69	6.19	2.00	.06	4	11/32	4	5/16-18	2	1/4"NPT	.69	3.25
108	3.81	3.69	4.94	1.95	.13	6	17/32	6	1/2-13	2	1/2" NPT	.50	1.50
208	5.06	4.88	6.13	1.95	.13	6	17/32	6	1/2-13	2	1/2" NPT	.50	2.87
111	4.00	3.94	5.25	3.02	.13	6	21/32	6	5/8-11	2	1/2" NPT	.75	2.00
211	5.75	5.63	6.63	3.02	.13	6	21/32	6	5/8-11	2	1/2" NPT	.75	3.75
114	4.63	4.56	6.63	3.88	.13	8	21/32	8	5/8-11	2	1/2" NPT	.88	2.25
214	6.69	6.56	8.56	3.88	.13	8	21/32	8	5/8-11	2	1/2" NPT	.88	4.25
118	5.13	5.63	7.88	4.88	.13	12	21/32	12	5/8-11	3	1/2" NPT	.81	2.75
218	7.44	7.31	9.56	4.88	.13	12	21/32	12	5/8-11	3	1/2" NPT	.81	4.75
124H	6.13	5.88	8.13	8.25	.13	12	21/32	12	5/8-11	3	1/2" NPT	.56	3.13
224H	8.50	8.38	10.81	8.25	.13	12	21/32	12	5/8-11	3	1/2" NPT	.56	5.13
130H	—	7.13	10.00	8.25	.19	18	25/32	18	3/4-10	4	1/2" NPT	.88	5.00
230H	—	10.38	13.25	8.25	.19	18	25/32	18	3/4-10	4	1/2" NPT	.88	7.13
136	—	7.00	11.19	12.75	.19	18	25/32	18	3/4-10	4	1/2" NPT	.88	4.25
236	—	10.25	14.44	12.75	.19	18	25/32	18	3/4-10	4	1/2" NPT	.88	7.50
142	—	8.38	11.25	20.50	.25	24	1-1/32	24	1-8	4	1/2" NPT	.75	5.62
242	—	12.13	15.00	20.50	.25	24	1-1/32	24	1-8	4	1/2" NPT	.75	7.50
148	—	9.56	13.93	19.00	.25	24	1-1/32	24	1-8	4	1/2" NPT1	.00	6.00
248	—	13.88	18.25	19.00	.25	24	1-1/32	24	1-8	4	1/2" NPT1	.00	8.75
260	—	17.75	22.38	20.63	.25	24	2" NC	24	2-4-1/2	6	1/2" NPT1	.00	9.37
360	—	22.25	26.88	20.63	.25	24	2" NC	24	2-4-1/2	6	1/2" NPT1	.00	14.13

Air Hose Kits

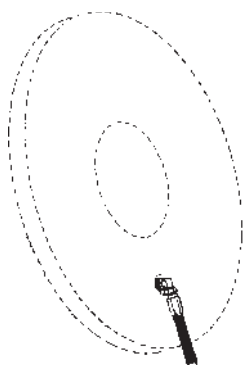

Model	Part Number
8"	8-908-912-100-5 8-908-924-100-5 QRV

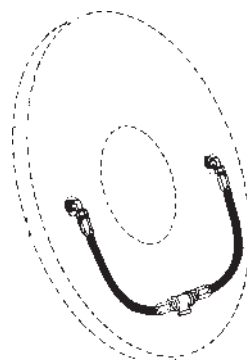

Model	Part Number
6"	8-906-912-200-4 8-906-931-201-5 QRV
8"	8-908-913-200-5 8-908-931-200-5
11"	8-911-913-200-5 8-911-931-200-5 QRV
14"	8-914-913-200-5 8-914-921-200-5 QRV
16"	8-916-913-200-5 8-916-921-200-5 QRV

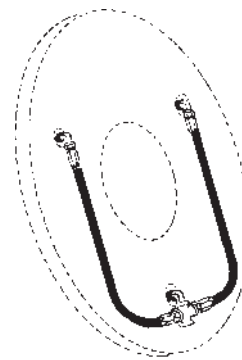

Model	Part Number
18"	8-918-912-200-5 8-918-931-200-5 QRV
21"	8-921-913-200-5 8-921-931-200-5 QRV
24"	8-924-913-200-5 8-924-931-200-5 QRV
27"	8-927-913-200-5 8-927-921-200-5 QRV

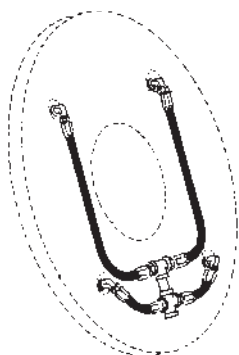

Model	Part Number
30"	8-930-913-400-5 8-930-931-400-5 QRV
36"	8-936-913-400-6 8-936-931-400-6 QRV
42"	8-942-913-400-6 8-924-931-400-6 QRV
48"	8-948-912-400-6 8-948-923-400-6 QRV

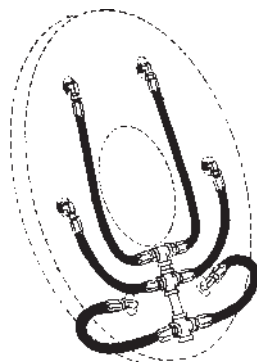

Model	Part Number
60"	8-960-912-500-5 8-960-923-400-6 QRV

Air hose kits contain all necessary parts (fittings, hoses and extensions) to completely plumb the brake air system.

Optional Quick Release Valves can replace elbows on most units (see page 61).

Roto-couplings (see page 61).

