

High Torque Clutches

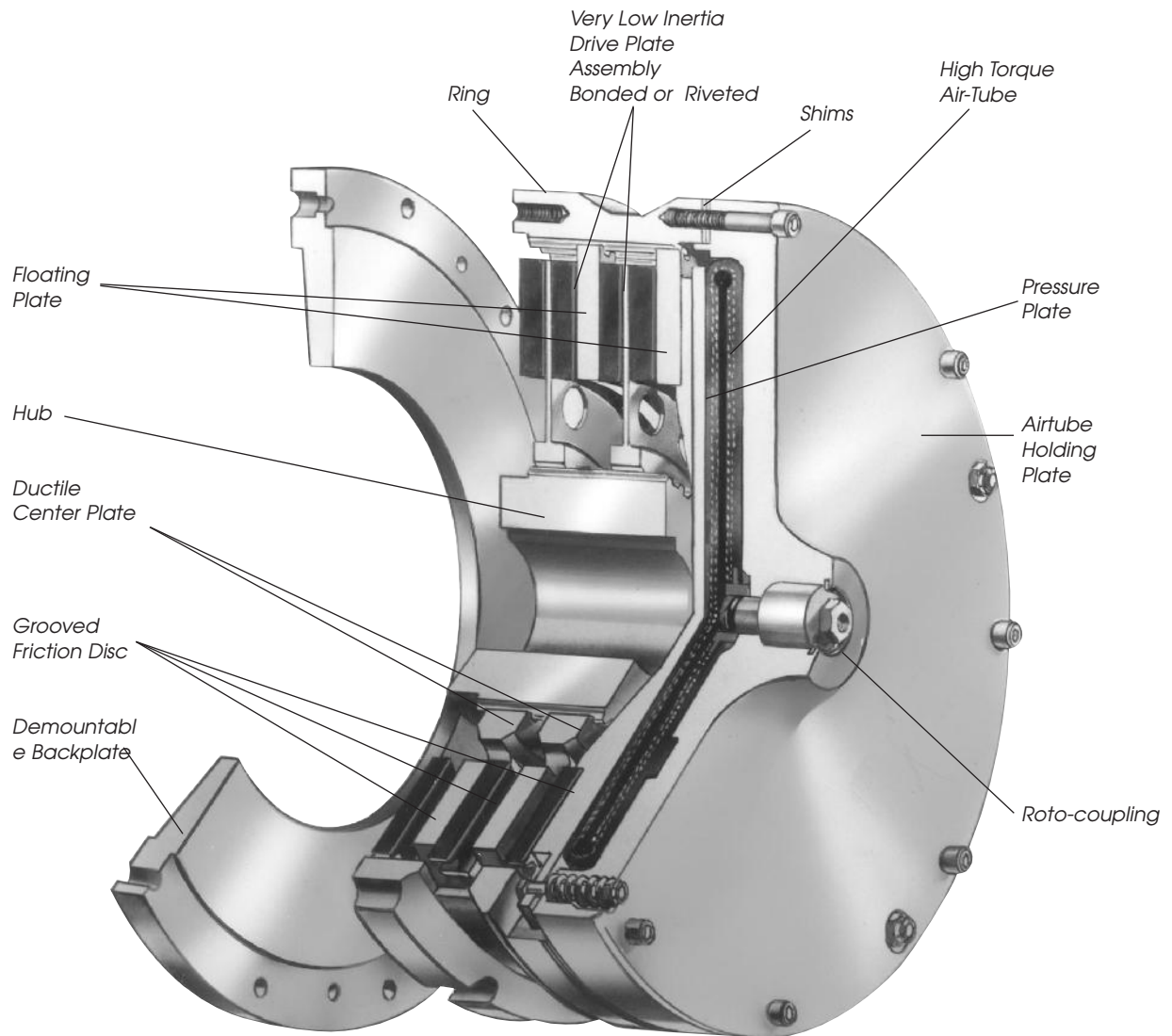

Wichita High Torque Clutches provide the highest torque to size ratios of any Wichita Clutch. They provide smooth controlled starts and stops and are designed for minimum power loss due to low rotating inertia.

- Extremely fast response
- No lubrication
- High torque to size ratio
- Low rotating inertia

Selection Requirements

To properly select a High Torque Clutch and Low Inertia Brake, the following information must be determined.

1. Torque necessary to do the work (clutch).
2. Rotating inertia to be stopped and started.
3. Heat generated by each stop/start.
4. Torque necessary to stop inertia (brake).
5. Shaft size.

Selection example

Data

Rated Tonnage As Required
 Crankshaft Speed 30 rpm
 (Continuous Run)
 Clutch-Brake Shaft rpm 204 rpm
 Crankshaft Speed 30 rpm
 Degrees of Crank to start 90°
 Degrees of Crank to stop 90°
 Connecting Rod Length = b 36 in.
 Stroke 6 in.
 1/2 of Press Stroke (throw) = a 3 in.
 WR² of Parts on Backshaft 78.2 lb.ft.²
 WR² of Parts on Crankshaft 39,091 lb.ft.²
 Material Shear Stress 45,000 psi
 Blade Width 60 in.
 Shaft Size 4 in.
 Maximum Material to be Sheared . . . x
 Air Pressure Available 100 psi

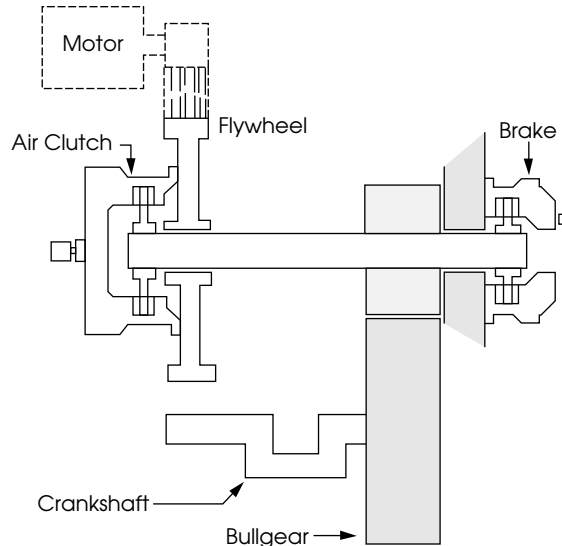

Calculations

Torque @ Crank

$$= (\text{Material Shear Stress}) (x) (\text{Blade Width}) (\text{Torque Arm})$$

Torque arm = y = (x) (tan α)

$$\begin{aligned} c &= a + b - x \\ &= 3 + 36 - .25 \\ &= 38.75 \text{ in.} \end{aligned}$$

Cos α

$$\begin{aligned} &= \frac{b^2 + c^2 - a^2}{2bc} \\ &= \frac{(36)^2 + (38.75)^2 - (3)^2}{(2)(36)(38.75)} \\ &= .99948 \\ \alpha &= 1.8478^\circ \end{aligned}$$

Torque Arm = y = (c) (tan α)

$$\begin{aligned} &= (38.75) (\tan 1.8478^\circ) \\ &= (38.75) (.03226) \\ &= 1.25 \text{ in.} \end{aligned}$$

Torque @ Crank

$$\begin{aligned} &= (\text{Material Shear Stress}) (x) (\text{Blade Width}) (\text{Torque Arm}) \\ &= (45,000) (.25) (60) (1.25) \\ &= 843,750 \text{ lb.in.} \end{aligned}$$

Torque @ Clutch

$$\begin{aligned} &= (\text{Torque @ Crank}) \div \frac{\text{Clutch rpm}}{\text{Crankshaft rpm}} \\ &= 843,750 \div \frac{204 \text{ rpm}}{30 \text{ rpm}} \\ &= 124,081 \text{ lb.in.} \end{aligned}$$

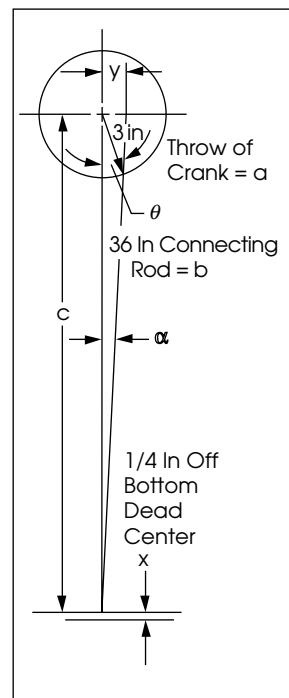

High Torque Clutches

Clutch Selection

Per the application factors on page 31 a "Back Geared Press is 'Group C'."

$$\frac{\text{hp}}{100 \text{ rpm}} = \frac{\text{Torque}}{630} = \frac{124,081}{630} = 197$$

The preliminary clutch selection based on 124,081 lb.in. and 197 hp/100 rpm is an ATD-224 Low Inertia High Torque Clutch. (page 41)

A Low Inertia High Torque Clutch was chosen because of the continuous duty (non-cyclic) operation having a relatively low heat hp requirement.

ATD-224 Low Inertia High Torque Clutch = 280 hp/100 rpm

Rated Torque = 480,000 lb.in @ 100 psi

Required clutch air pressure is:

$$\text{psi} = \frac{\text{clutch required torque} \times (100 \text{ psi})}{\text{Catalog rated torque @ 100 psi}}$$

Actual required clutch psi

$$\text{psi} = \frac{124,081}{480,000} \times (100 \text{ psi}) = 26 \text{ psi minimum is required.}$$

This application has 100 psi available.

Contact velocity of rotating disc is:

$$V_c = \frac{(\text{Diameter of Center Plate}) (\pi) (\text{rpm})}{12 \text{ in.ft.}}$$

$$= \frac{24}{12} (\pi) (204) = 1,282 \frac{\text{ft.}}{\text{min.}}$$

(Ductile iron is not required, see page 31).

Maximum bore for ATD-224 High Torque Low Inertia Clutch = 7 in.

Check clutch inflation time for 90° start angle (see page 48, psi pressure curves)

Estimated time to start

$$= \frac{\text{Start Angle}}{360^\circ} \frac{60}{\text{Crankshaft rpm}}$$

$$= \frac{90^\circ}{360^\circ} \frac{60}{30} = 0.5 \text{ Sec.}$$

- P_1 = Line pressure to clutch.
- P_2 = Required pressure to clutch.
- LN = Natural log.
- k = Inflation coefficient (ATD-224 H.T. @ 100 psi).
- = 2,600
- u = For ATD-224 H.T. Clutch @ 100 psi
- = 2.5

Time to 26% of line pressure.

$$t = \left[\frac{\text{LN} \left[\frac{P_1}{P_1 - P_2} \right]}{k} \right]^{\frac{1}{u}}$$

$$t = \left[\frac{\text{LN} \left[\frac{100}{100 - 26} \right]}{2,600} \right]^{\frac{1}{2.5}}$$

$$= 0.027 \text{ seconds}$$

Clutch will be fully inflated at 90° of crankshaft rotation.

Clutch exhaust time @ 100 psi = E = .078 (page 48).

Note:

This application example is for preliminary sizing only. Contact a Wichita Sales Engineer or the factory for final selection.

Low Inertia Brake Selection

To properly size a brake, the total rotating inertia reflected to the clutch and brake shaft must be known.

Alternate shaft WR²
referred to clutch shaft

$$= \frac{\text{Alternate shaft WR}^2}{\left[\frac{\text{Alternate shaft rpm}}{\text{clutch shaft rpm}} \right]^2}$$

$$= 39,091 \left[\frac{30}{204} \right]^2$$

WR² referred to clutch-brake shaft = 845.4 lb.ft.²
@204 rpm
Total inertia = 78.2 lb.ft.²
Back shaft WR²

Clutch hub & drive plate WR² from Specification Table = 101.0 lb.ft.²

Estimate brake WR² (assume same as clutch) = 101.0 lb.ft.²

Total WR² referred to clutch-brake = 1,125.66 lb.ft.² (Estimated)

Estimated time to stop:

$$= \left[\frac{\text{Start Angle}}{360^\circ} \right] \left[\frac{60}{\text{Crankshaft rpm}} \right]$$

$$= \left[\frac{90^\circ}{360^\circ} \right] \left[\frac{60}{30} \right] = .5 \text{ Sec.}$$

The deceleration torque is

$$T = 12 \left[\frac{\text{WR}^2}{32.2} \right] \left[\frac{\text{Brake rpm}}{9.5(t)} \right]$$

$$= 12 \left[\frac{1125.6}{32.2} \right] \left[\frac{204}{9.5 (.5)} \right]$$

Deceleration Torque = 18,015 lb. in.

The hp / 100 rpm for this application is:

$$\frac{\text{hp}}{100 \text{ rpm}} = \frac{\text{Torque (lb.in.)}}{630} = \frac{18,015}{630} = 29 \text{ hp} / 100 \text{ rpm}$$

Consult the Specification Table on page 34 to select a brake based on torque and hp/100 rpm. Under "Duty C", an ATD-214 brake has 32 hp/100 capacity and 55,250 lb.in. torque. The rotating inertia of an ATD-214 Low Inertia Brake is 11 lb.ft.². Therefore, the actual rotating inertia reflected to brake is 1035.6 lb.ft.².

$$\text{The actual deceleration torque} = 12 \left[\frac{1035.6}{32.2} \right] \left[\frac{204}{9.5} \right]$$

$$= 16,575 \text{ lb.in.}$$

Required air pressure is:

$$\text{Brake} = \frac{\text{Brake required torque} \times (100 \text{ psi})}{\text{Catalog rated torque @ 100 psi}}$$

$$= \frac{16,575 \text{ lb.in.} \times 100}{55,250 \text{ lb.in.}}$$

$$= 30 \text{ psi minimum}$$

This application has 100 psi available.

The average heat hp each stop

$$= \frac{(\text{Brake Torque}) \times \text{rpm} \times 1/2}{63,000}$$

$$= \frac{16,575 \times 204 \times .5}{63,000}$$

$$= 26.8 \text{ hp}$$

$$\text{Friction area necessary to absorb heat} = \frac{\text{heat hp}}{\text{Absorption rate for .5 sec (see page 160)}}$$

$$= \frac{\text{Heat hp}}{.7} = \frac{26.8}{.7} = 39 \text{ in.}^2$$

An ATD-214 Low Inertia Brake has 316 in.² of friction lining available to absorb heat generated by stopping. Maximum bore for an ATD-214 Low Inertia Brake is 4-1/8 inches.

Based on the given application data and the following calculations, an ATD-224 Low Inertia High Torque Clutch and ATD-214 Low Inertia Brake have been selected as having sufficient torque and heat dissipation capacity with minimum diameter and sufficient bore capacity.

Note:

These application examples are for preliminary sizing only. Contact a Wichita Sales Engineer or the factory for final selection.

High Torque Clutches

Specifications

Model Size ATD-	Slip Torque Lb. In At 100 PSI* .3CF	Maximum Horsepower Per 100 RPM Duty				Max. Bore Rect. Key Inches	Recommended Clearances Inches	Swept Friction Area In. ²	Air-Tube Volume In. ³	
		A	B	C	D				New Lining	Worn Lining
106	5,000	8	5.7	2.8	1.4	2	1/16-3/32	39	3	14
206	10,000	16	11.4	5.7	2.8	2	1/16-3/32	78	4	14
108	11,000	17	12.5	6.2	3.1	2-3/8	1/16-1/8	56	5	30
208	22,000	34	25	12.5	6.2	2-3/8	3/32-5/32	112	7	30
111	25,000	38	28	14	7	2-5/8	1/16-1/8	114	8	48
211	50,000	76	56	28	14	2-5/8	3/32-5/32	228	11	48
114	48,000	75	55	27	14	4-1/8	1/16-1/8	158	12	75
214	96,000	160	114	55	28	4-1/8	3/32-5/32	316	17	75
118	105,000	165	120	60	30	5-1/4	1/16-1/8	264	20	140
218	210,000	330	240	120	60	5-1/4	3/32-5/32	528	35	140
124	240,000	385	280	140	70	7	3/32-5/32	574	50	250
224	480,000	770	560	280	140	7	1/8-3/16	1,148	75	250
130	470,000	750	535	270	135	8-1/2	3/32-5/32	827	80	395
230	940,000	1500	1070	540	270	8-1/2	1/8-3/16	1,654	120	395
136	940,000	1555	1120	560	280	10-1/2	3/32-5/32	1,150	120	770
236	1,880,000	3100	2240	1120	560	10-1/2	1/8-3/16	2,300	150	770
148	2,360,000	3745	2690	1345	670	18	1/8-3/16	2,010	200	1430
248	4,720,000	7490	5380	2690	1345	18	5/32-7/32	4,020	300	1430

*Max. recommended air pressure — 100 PSI.

Model No.	
Model Size	Model Type
ATD-xxx	LI-HTC for Low Inertia High Torque Clutch
ATD-xxx	VLI-HTC for Very Low Inertia High Torque Clutch

Note: Very Low Inertia High Torque Clutches are available in sizes from ATD-108 to ATD-224.



Model Size ATD-	Low Inertia High Torque					Very Low Inertia High Torque				
	Total Wt. Lbs.	Total WR ² #Ft. ²	HUB & CP Wt. Lbs.	HUB & CP WR ² #Ft. ²	Effec. Wt.† Lbs.	Total Wt. Lbs.	Total WR ² #Ft. ²	HUB & DP Wt. Lbs.	HUB & DP WR ² #Ft. ²	Effec. Wt. † Lbs.
106	22.5	1.4	6.40	.24	6.99	—	—	—	—	—
206	37.7	2.8	12.7	.46	11.38	—	—	—	—	—
108	60.78	7.33	10.0	.55	12.80	59.2	7.24	8.2	.74	15.83
208	79.05	9.65	16.0	.72	19.30	77.21	9.35	15.3	1.5	23.36
111	109.4	21.43	15.0	1.35	21.35	110.1	21.79	14.0	.83	28.15
211	148.44	28.72	30.0	2.60	39.65	145.74	29.27	26.0	1.60	46.95
114	120	31	48	5.6	35	119	23.6	30.4	2.7	38
214	171	45	65	11	59	146	34.2	51.8	5.2	52
118	284	108	71	14.5	91	278.4	100.5	44.4	7.5	67
218	406	177	113	27.6	133	382.6	166.4	66.6	13.4	151
124	599	431	131	50	196	566.5	409	107.5	27	231
224	783	530	260	101	301	727	494	181	41	273
130	1099	1424	212	129	348	—	—	—	—	—
230	1460	1718	402	244	528	—	—	—	—	—
136	1762	2554	351	325	620	—	—	—	—	—
236	2375	3513	784	705	937	—	—	—	—	—
148	5471	15245	1101	1785	1773	—	—	—	—	—
248	6802	19150	1942	3335	2459	—	—	—	—	—

† Weight of internal clutch parts for use in calculating clutch engagement time.

Air system data

PSI pressure

Inflation

Clutch air pressure during inflation can be closely estimated by the following:

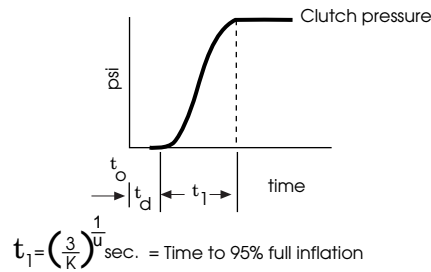

Clutch pressure = $P_1 \left(1 - \frac{1}{e^{Kt^U}}\right)$ psi
(inflation)

This equation is accurate from 5% up to 95% P_1 .

P_1 = Line pressure to clutch psi

K and U = coefficients for specific clutch and air pressure from Specification Table on page 53.

e = Napierian base log

t_o = Time at initiation of signal for inflation sec.

t_d = Time delay of air system – sec.

Exhaust

Clutch air pressure during exhaust can be closely estimated by the following:

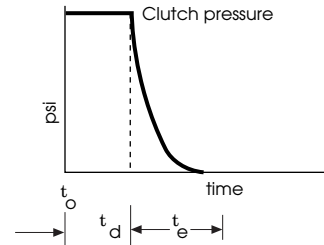

Clutch pressure = $(P_1) (R) (E-t)^V$ psi
(exhaust)

R, E and V = coefficients for specific clutch and air pressure from Specification Table on page 53.

t_e = Time to exhaust = E from Specification Table on page 53.

t = Time variable – seconds. In the exhaust equation “ t ” cannot exceed the value of “ E ” sec.

Shown are some of the air systems used on Wichita clutches. These systems are acceptable for remote operation where clutch reaction time is not important. Faster clutch reaction time is accomplished as indicated in the diagram by locating the flow control valve, if required, and the solenoid valve as close as possible to the roto-coupling. Where clutches are located on long shafts, the use of quick release valves on the clutch will facilitate faster clutch response.

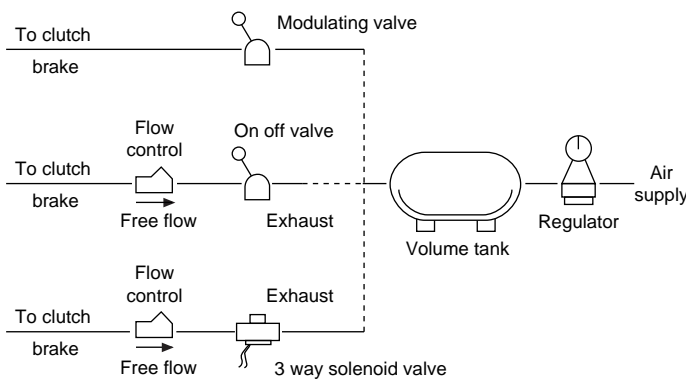

Overlap

A typical clutch-brake torque curve for a single backshaft press (cyclic application) would appear as shown below.

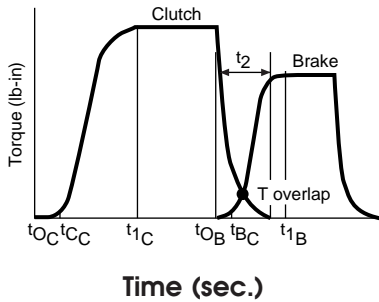

- t_{0c} = time at which disengaged clutch receives signal
- t_{Cc} = time of clutch engagement
- t_{1c} = time of clutch full inflation
- t_{0B} = time at which disengaged brake receives signal
- t_{Bc} = time of brake engagement
- t_{1B} = time of brake full exhaust
- t_2 = overlap time at which clutch and brake are both engaged

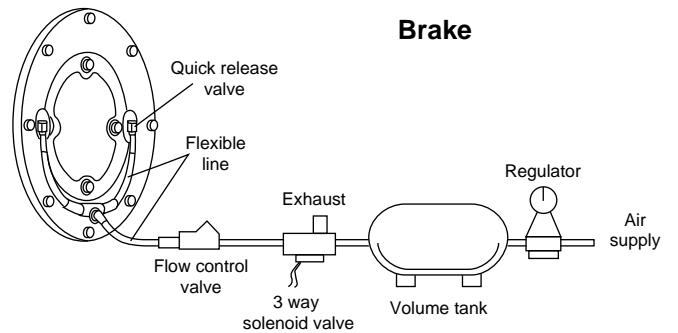
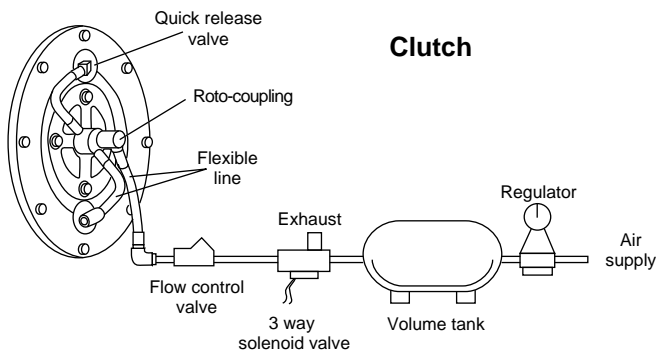

High Torque Clutches

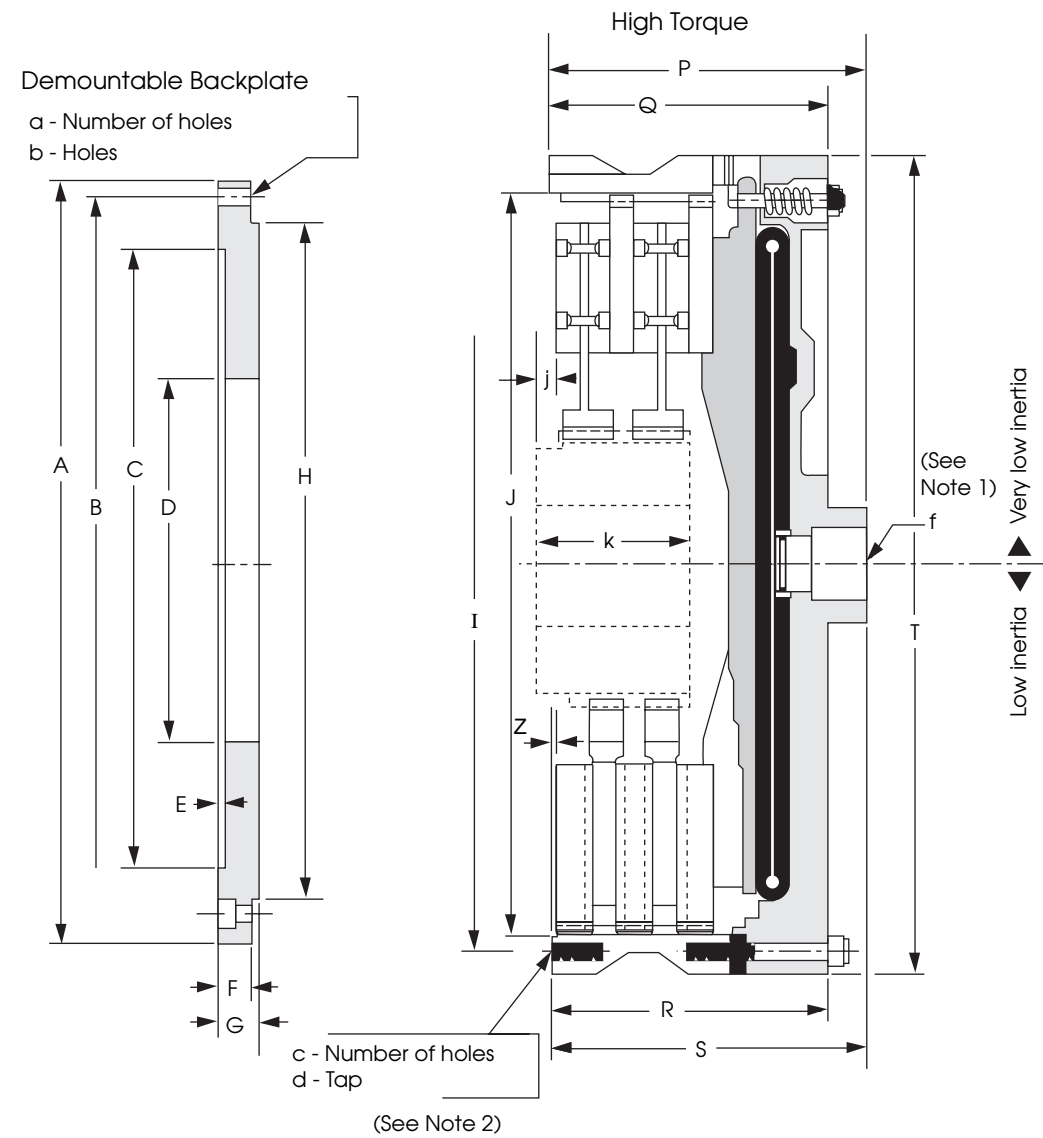

Notes:

1. Roto-couplings, see page 61.
2. Quick Release Valves, see page 61.
3. VLI Drive Plates available with bonded or riveted pads.

Dimensions (in)

(Consult factory for drawing before final layout.)

Model Size ATD-	A	B	C	D	E	F	G	H	I	J
106	8.75	8.000	7.377/7.379	4.19	.06	.562	.69	7.373/7.375	8.000	7.377/7.379
206	8.75	8.000	7.377/7.379	4.19	.06	.562	.69	7.373/7.375	8.000	7.377/7.379
108	12.12	11.125	8.375/8.378	5.38	.25	.875	1.00	9.281/9.284	10.187	9.285/9.288
208	12.12	11.125	8.375/8.378	5.38	.25	.875	1.00	9.281/9.284	10.187	9.285/9.288
111	16.00	14.750	11.375/11.378	7.00	.38	1.125	1.25	12.370/12.373	13.500	12.375/12.378
211	16.00	14.750	11.375/11.378	7.00	.38	1.125	1.25	12.370/12.373	13.500	12.375/12.378
114	18.75	17.500	14.375/14.378	9.43	.38	1.125	1.25	15.121/15.124	16.250	15.125/15.128
214	18.75	17.500	14.375/14.378	9.43	.38	1.125	1.25	15.121/15.124	16.250	15.125/15.128
118	23.25	22.000	18.250/18.253	12.50	.38	1.125	1.25	19.495/19.498	20.750	19.500/19.503
218	23.25	22.000	18.250/18.253	12.50	.38	1.125	1.25	19.495/19.498	20.750	19.500/19.503
124	30.00	28.750	24.375/24.378	14.50	.25	1.125	1.25	25.497/25.499	26.750	25.500/25.503
224	30.00	28.750	24.375/24.378	14.50	.25	1.125	1.25	25.497/25.499	26.750	25.500/25.503
130	37.00	35.500	30.375/30.378	19.25	.25	1.250	1.43	32.118/32.123	33.250	32.125/32.128
230	37.00	35.500	30.375/30.378	19.25	.25	1.250	1.43	32.118/32.123	33.250	32.125/32.128
136	43.50	42.000	36.375/36.378	23.63	.25	1.500	1.75	38.120/38.123	39.75	38.125/38.128
236	43.50	42.000	36.375/36.378	23.63	.25	1.500	1.75	38.120/38.123	39.75	38.125/38.128
148	61.00	58.000	52.000/52.005	32.00	.25	1.500	1.75	51.993/51.998	54.000	52.000/52.005
248	61.00	58.000	52.000/52.005	32.00	.25	1.500	1.75	51.993/51.998	54.000	52.000/52.005

Model Size ATD-	P	Q	R	S	T	Z	a	b	c	d	f	j	k
106	—	—	4.00	4.50	8.81	.06	4	11/32	4	5/16-18	5/8-18	.69	2.00
206	—	—	5.19	5.69	8.81	.06	4	11/32	4	5/16-18	5/8-18	.69	3.25
108	4.31	3.68	3.63	5.25	11.13	.13	6	17/32	6	1/2-13	1/4" NPT	.50	1.50
208	5.56	4.93	4.88	6.50	11.13	.13	6	17/32	6	1/2-13	1/4" NPT	.50	2.87
111	6.63	4.50	4.38	6.50	14.75	.13	6	21/32	6	5/8-11	1/2" NPT	.75	2.00
211	8.25	6.13	6.13	8.25	14.75	.13	6	21/32	6	5/8-11	1/2" NPT	.75	3.75
114	7.18	5.13	4.81	6.96	17.50	.13	8	21/32	8	5/8-11	1/2" NPT	.88	2.25
214	9.13	7.06	6.94	9.00	17.50	.13	8	21/32	8	5/8-11	1/2" NPT	.88	4.25
118	—	5.90	6.09	7.96	22.00	.13	12	21/32	12	5/8-11	1/2" NPT	.81	2.75
218	—	8.03	7.91	9.78	22.00	.13	12	21/32	12	5/8-11	1/2" NPT	.81	4.75
124	8.38	6.81	7.00	8.43	29.00	.13	12	21/32	12	5/8-11	1/2" NPT	.56	3.13
224	10.94	9.50	9.43	10.88	29.00	.13	12	21/32	12	5/8-11	1/2" NPT	.56	5.13
130	—	—	9.25	16.06*	36.13	.19	18	25/32	18	3/4-10	1-1/2"-12	.88	5.00
230	—	—	10.31	18.06*	36.13	.19	18	25/32	18	3/4-10	1-1/2"-12	.88	6.25
136	—	—	10.31	18.87*	41.50	.19	18	1-1/32	18	3/4-10	2" NPT	.88	4.25
236	—	—	13.56	22.13*	41.50	.19	18	1-1/32	18	3/4-10	2" NPT	.88	7.50
148	—	—	15.44	24.00*	59.00	.25	24	1-1/32	24	1-8	2" NPT	1.00	6.00
248	—	—	19.75	28.31*	59.00	.25	24	1-1/32	24	1-8	2" NPT	1.00	8.75

‡ 30" sizes and larger furnished with external roto-coupling.

Notes: Very Low Inertia High Torque Clutches are available in sizes from ATD-108 to ATD-224. See page 34. For mounting, use socket head cap screws conforming to the ASTM-574-97a.

High Torque Clutches Component Parts

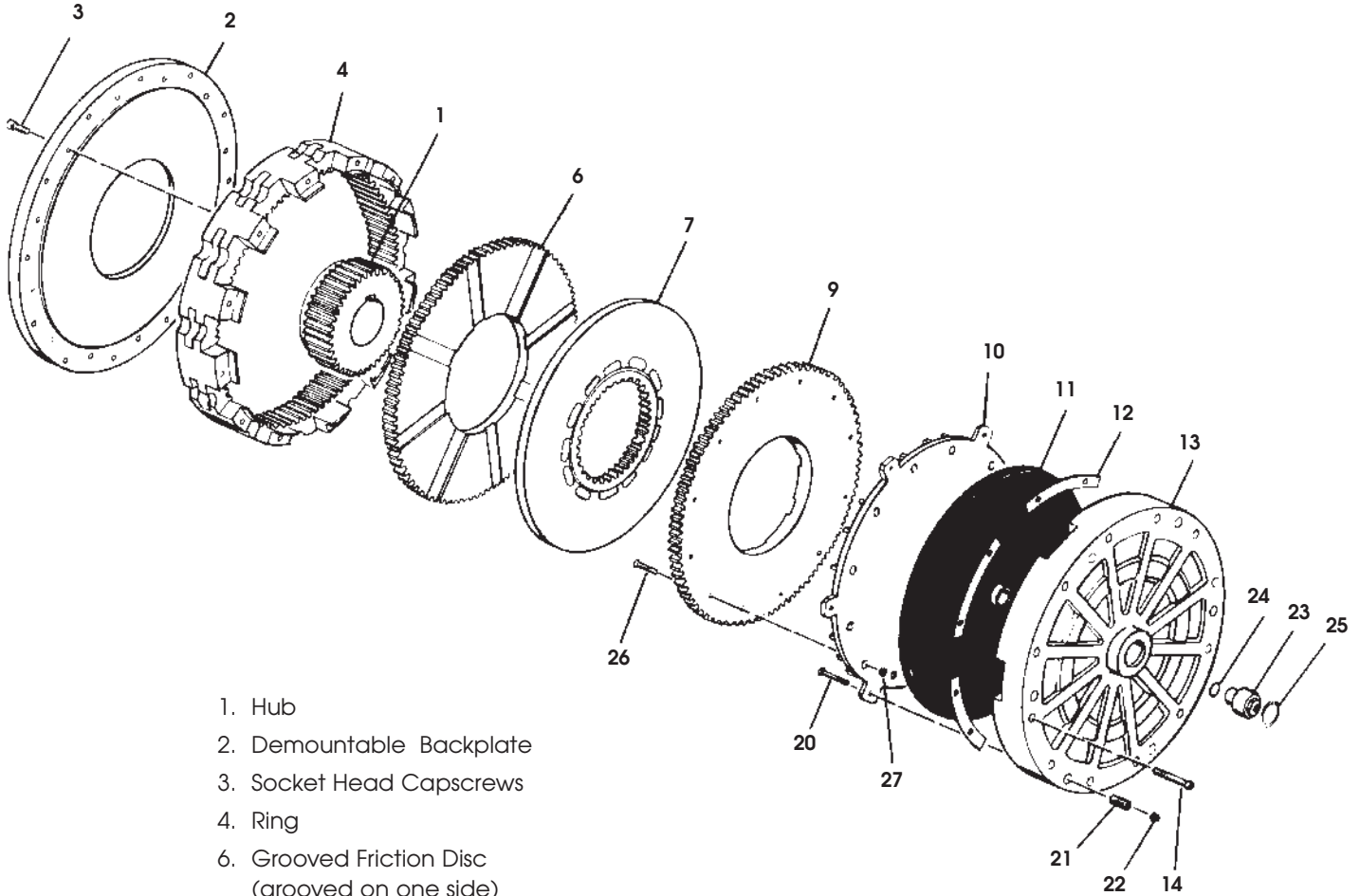

- | | |
|---|------------------------------|
| 1. Hub | |
| 2. Demountable Backplate | |
| 3. Socket Head Capscrews | |
| 4. Ring | |
| 6. Grooved Friction Disc
(grooved on one side) | |
| 7. Center Plate | |
| 9. Grooved Friction Disc | |
| 10. Pressure Plate | |
| 11. Pancake Air Tube | |
| 12. Shims | |
| 13. Air Tube Holding Plate | |
| 14. Socket Head Capscrews | |
| 20. Hex Head Capscrew | |
| | 21. Release Springs |
| | 22. Flexloc Nut |
| | 23. Internal Roto-Coupling |
| | 24. "O" Ring |
| | 25. Snap Ring |
| | 26. Flathead Socket Capscrew |
| | 27. Slotted Flush Nut |



High Torque Clutches

Inflation Coefficients

Model Size ATD-	Inflation Coefficients Operating Air Pressure					
	50 PSI		75 PSI		100 PSI	
	K	U	K	U	K	U
111	393000	3	151000	3	5100	4
211	393000	3	151000	3	5100	4
114	49000	3	30000	3	17600	3
214	49000	3	30000	3	17600	3
118	5700	2.8	5700	2.8	7500	3
218	5700	2.8	5700	2.8	7500	3
124	10400	3	5200	2.7	2600	2.5
224	10400	3	5200	2.7	2600	2.5
130	940	2.2	1070	2.2	590	2
230	940	2.2	1070	2.2	590	2
136	77000	3.5	58000	3.5	44000	3.5
236	77000	3.5	58000	3.5	44000	3.5
148	1200	2.5	1240	3.5	800	2.5
248	1200	2.5	1240	3.5	800	2.5

Exhaust Coefficients

Model Size ATD-	Exhaust Coefficients Operating Air Pressure								
	50 PSI			75 PSI			100 PSI		
	R	E	V	R	E	V	R	E	V
111	480000	.04	4	180000	.05	4	*	.056	5
211	480000	.04	4	180000	.05	4	*	.056	5
114	5600	.032	2.5	2200	.044	2.5	910	.064	2.5
214	5600	.032	2.5	2200	.044	2.5	910	.064	2.5
118	4100	.062	3	9800	.1	4	8500	.104	4
218	4100	.062	3	9800	.1	4	8500	.104	4
124	280	.06	2	775	.068	2.5	575	.078	2.5
224	280	.06	2	775	.068	2.5	575	.078	2.5
130	690	.072	2.5	500	.083	2.5	500	.084	2.5
230	690	.072	2.5	500	.083	2.5	500	.084	2.5
136	86	.048	1.5	76	.056	1.5	1100	.064	1.5
236	86	.048	1.5	76	.056	1.5	1100	.064	1.5
148	160	.11	2.3	120	.136	2.4	111	.15	2.5
248	160	.11	2.3	120	.136	2.4	111	.15	2.5

* 1.88 x 10⁶

Distribuidor Autorizado e Importador - Arten Freios e Embreagens Ltda.
Fone: (11) 5594-8333 • Fax (11) 5589-2422 - arten@arten.com.br • www.arten.com.br