

■ **Low Inertia and Very Low Inertia clutches and brakes**

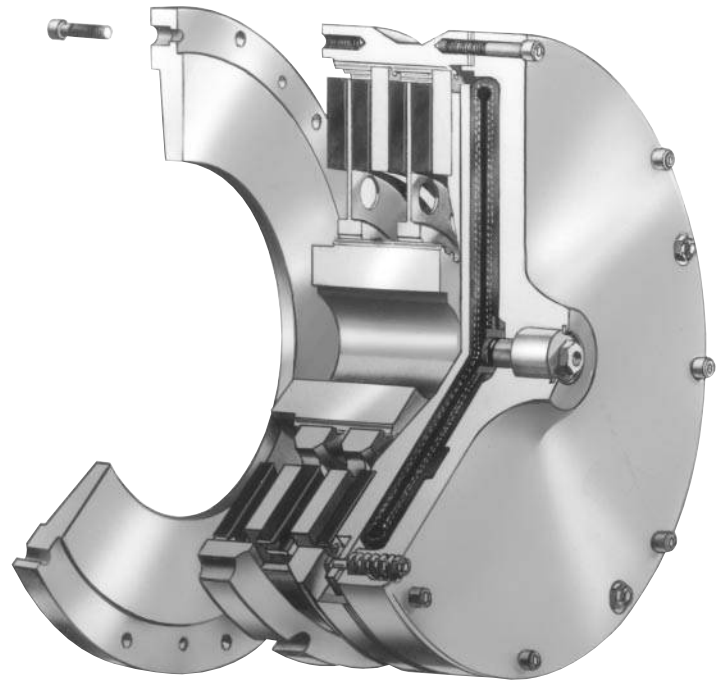

■ **High-torque clutches**

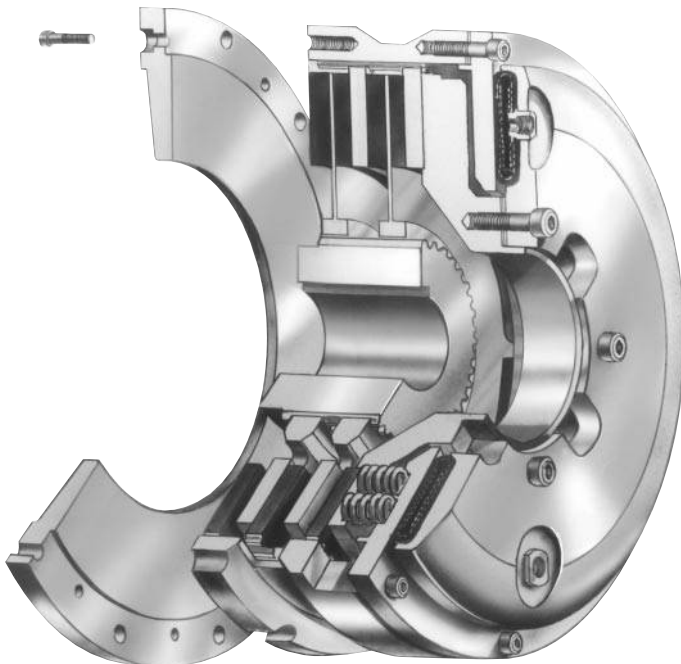

■ **Spring-Set air release brakes**

Wichita Air Tube Disc Clutches and Brakes provide the high speed acceleration and deceleration essential for today's process equipment. The low-inertia designs reduce power consumption and heat build-up in cycling applications. A quick energizing air-tube provides fast response with smooth engagement.

Clutch and brake combinations

4 Clutch combinations

Low inertia
 Very low inertia
 Low inertia high torque
 Very low inertia high torque

4 Brake combinations

Low inertia
 Very low inertia
 Low inertia spring-set
 Very low inertia spring-set

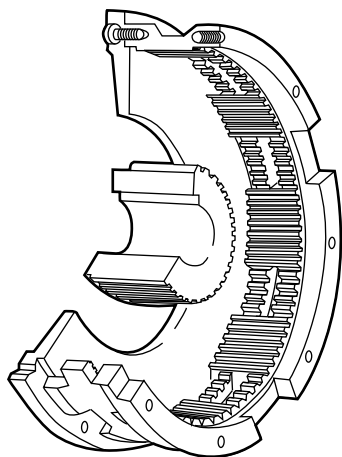

Ring with demountable backplate and hub

- Ring with demountable backplate can be used with any of the actuators shown.
- Hub can be used with either the Very Low Inertia or the Low Inertia center plates and friction discs.
- Very Low Inertia design utilizes thick segmented friction discs which increases friction disc life and heat dissipation.

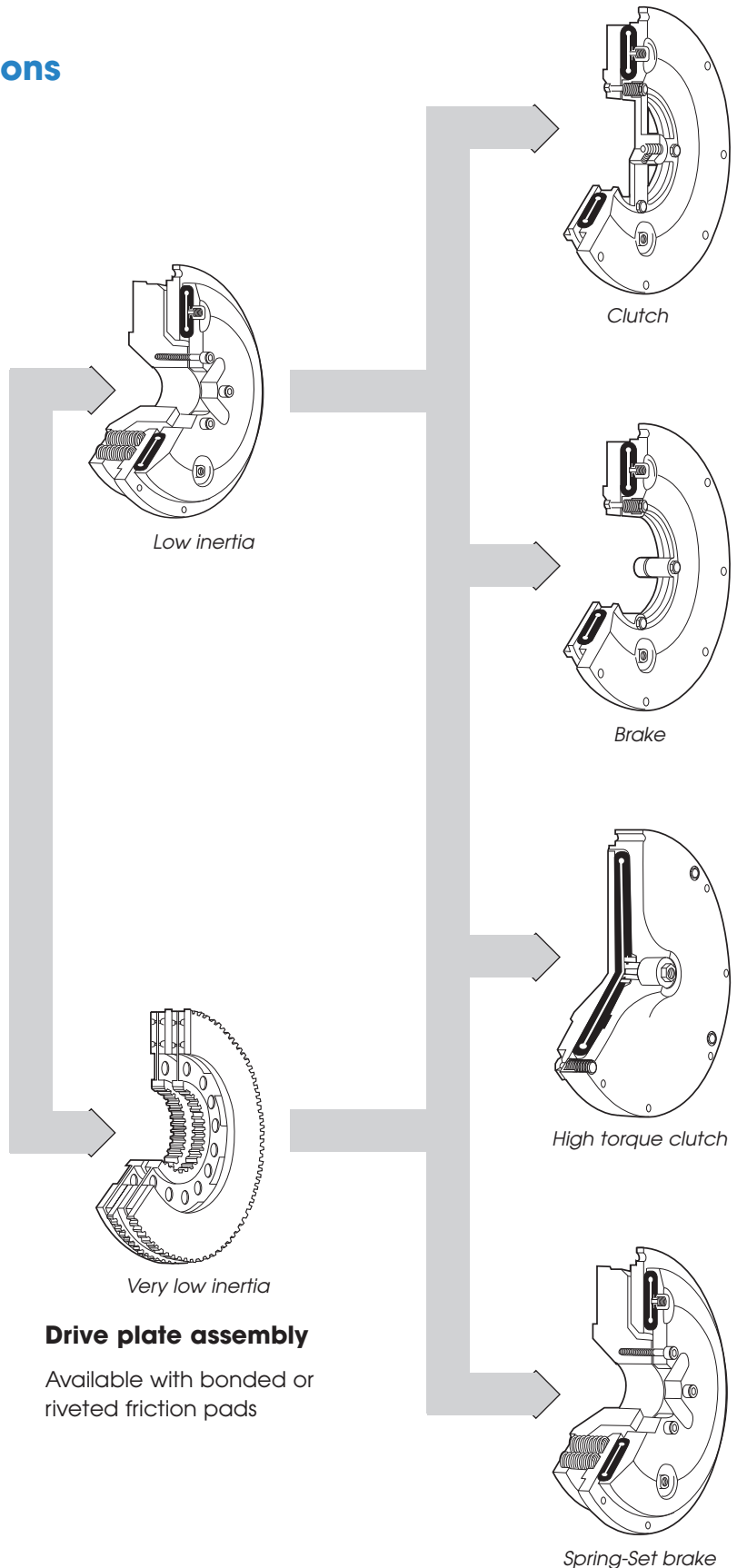

Drive plate assembly

Available with bonded or riveted friction pads

**Air Tube Plate
 (function) Assembly**

Typical Applications

Wichita High Torque Clutch provides fast acceleration and long life on metal forming punch presses.

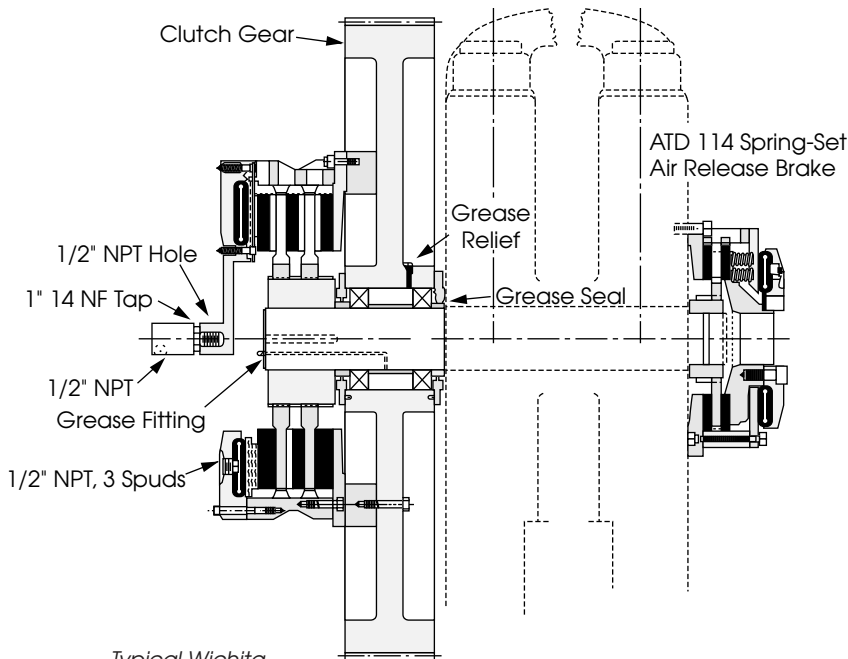
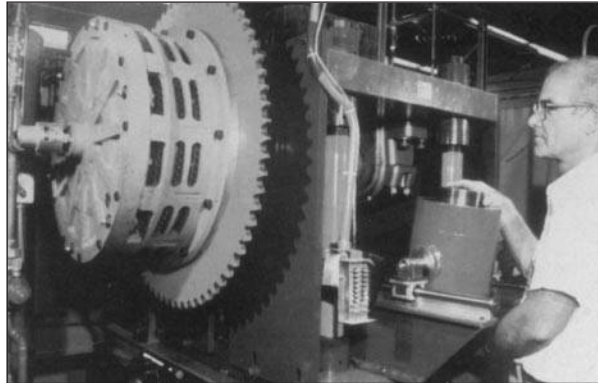

Typical Wichita clutch and brake mounting on a press.

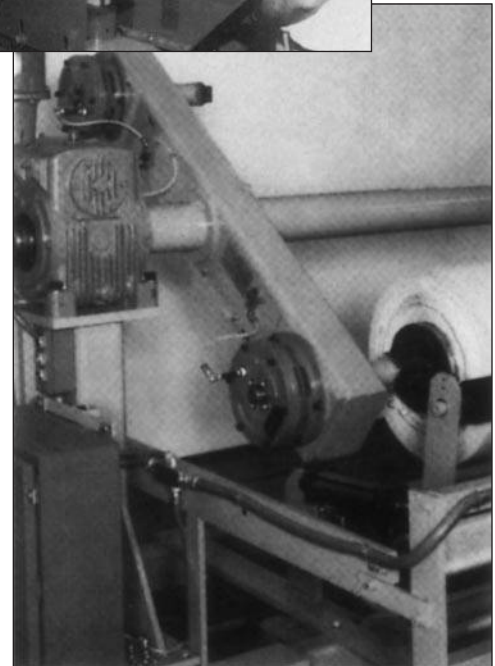

Wichita Low Inertia Brakes increase tension control for paper unwind stands.

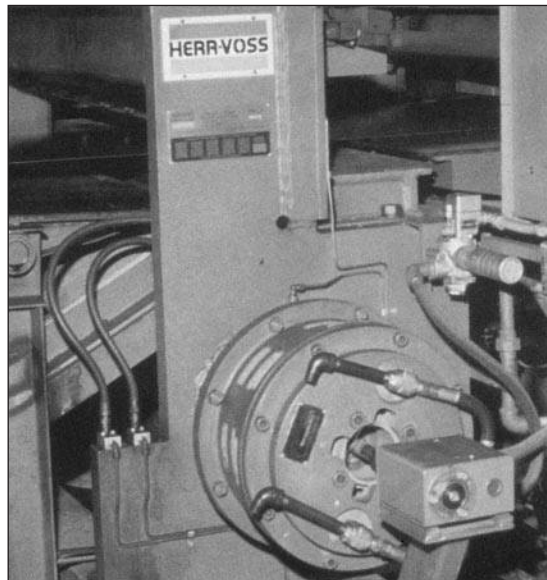

Wichita Spring-Set Air Release Brakes insure accuracy and high performance for a metal shear.



Application Factors

Clutch sizes are affected by the following variables:

1. Machines that operate under smooth loads require smaller clutches. These machines are driven by either multi-cylinder high speed engines or electric motors with reduced starting current.
2. Drives that require high starting current motors will require clutches with sufficient torque to prevent excessive slipping while starting.
3. Starting torque may be high, which requires a fast clutch response time to transmit the required torque or extended clutch slip time is required to protect the prime mover.
4. Starting torques may be very low compared to the normal torque, which may result in the clutch not being fully pressurized prior to the time of full torque requirement. This will cause the clutch to overheat from slippage. Clutch inflation time in this instance is very important.
5. Clutches on most machines are designed to slip prior to damage from shockloads. As a result, the clutch may require periodic maintenance; therefore, the clutch should be located for easy access in the power train. Clutches should also be located for maximum cooling air. In instances where this is not possible, forced air cooling may be necessary for extended clutch life.
6. Safe clutch operating speeds should be maintained in product design.

Maximum Clutch Contact Velocity

FPM	Material
6,000 (Recommended)	cast iron
9,000 (upper limit for slip)	ductile iron
12,000	steel

Dynamic balancing recommended when peripheral speeds exceed 3500 fpm. The maximum speeds shown are safe operating speeds based on years of Wichita testing. Please do not exceed these limits.

Application Guidelines

This chart gives application factors ranging from light duty (the A group) to extra heavy duty (the D group).

After initial usage is determined, see

“Selection Requirements” to complete the selection process. The inflation and exhaust time should also be checked to insure proper response.

Field of Application	Group A	Group B	Group C	Group D
Pumps		Centrifugal compressors	Reciprocating compressors over 2 cylinders, centrifugal fans & blowers	Reciprocating compressors one or two cylinders
Agitators	Liquid	Semi-solid	Solids	
Brick manufacturing			Brick press, extruder, pug mill	
Canning & bottling machine		Bottle-can feeders, filling, mixers		
Engine driven equipment			Crane, hoist, engine	Crowd
Grinding mills			Ball-rod-sag-pebble	Crushers, shakers
Lumber processing		Yarder	Carriages, conveyers	Chipper, logger
Marine		Propulsion clutch CP wheel	Shaft brakes, propulsion reversing type, anchor winch	
Bulk material handling	Conveyors evenly loaded, line shaft evenly loaded	Feeders	Elevators	
Metal production & metalforming		Coilers, slitters, press brake, non-gearred press, geared press	Draw bench, rolling mill, shear, back geared press, deep draw press, transfer press, toggle press	Hammer mill, forming press, forging press, header press, knuckle press
Paper industry dryer sections & calenders Consult factory			Fourdrinier to 500 FPM, paper mill plane & smoothing press	Fourdrinier to 1800 RPM press selections, calenders & dryers
Petroleum production		Drilling & service rig master clutches, compound clutches, rotary, drum		Mud pumps, PTO clutches
Rubber manufacturing	Transfer machines evenly loaded		Banberry mixer, drum mixer, extruder, calender	Centrifuge

Low Inertia and Very Low Inertia Clutches and Brakes

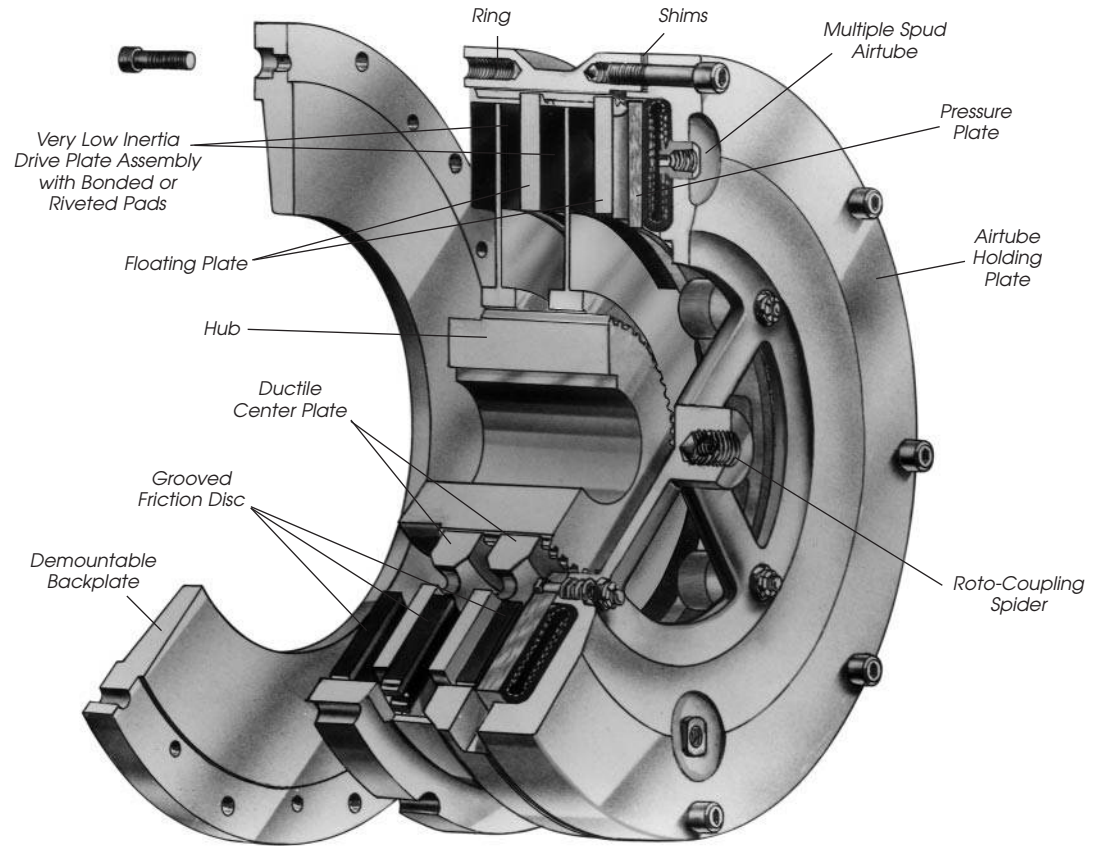

Operating Features

The Wichita Air-Tube Disc Clutch combines all the best features of the disc type clutch with all the advantages of direct air engagement. The simplest and most trouble-free method of applying air pressure is through direct axial pressure application by compressed air in a special composition full-circle tube.

Wichita Clutches engage smoothly without noise, shock or impact and release completely in a fraction of a second. Extremely fast action is possible because of the small volume of air required.

Clutches may be slipped moderately to control the acceleration rate.

When large inertia loads are powered from electric motors, smooth, controlled slip starts by Wichita Clutches can keep power demands below the allowed maximum.

Heat generated by controlled slipping or high cycle rate operation is dissipated by the centrifugal blower design of these units.

Wichita Low Inertia and Very Low Inertia Clutches and Brakes are designed to be completely free from effects of centrifugal force and self energization.

Torque developed is in direct proportion to air pressure applied.

These clutches and brakes interface well with automated controls through simple air and/or electric circuits.

Water cooled, copper disc clutches are available for use when power transmission needs require excessive or constant slipping which demands higher heat dissipation.

Wichita Clutches operate perfectly when teamed with Wichita Brakes in production situations requiring tension control, cyclic duty, or positioning.

Wichita Brakes have the same outstanding performance characteristics as Wichita Clutches.

Selection Requirements

The selection of a Low Inertia Brake is based on:

1. Torque required to stop a load.
2. Friction area necessary to absorb rotational energy.
3. Contact velocity of rotating discs.
4. Maximum bore capacity of unit.

Selection example

To properly select a Low Inertia Brake for a controlled deceleration application, the following information is needed:

Speed 750 rpm
 Shaft Dia. 5 In.
 Inertia to Stop 2,473 lb.ft.²
 Stop Time 5 Sec.
 Air Pressure Available 80 psi

Calculations

$$\begin{aligned} \text{Avg. hp} &= \frac{WR^2 \times (\text{rpm})^2}{3.2 \times 10^6 \times \text{Stop Time}} \\ &= \frac{2,473 \times (750)^2}{3.2 \times 10^6 \times 5 \text{ Sec.}} = 87 \text{ HP} \end{aligned}$$

$$\begin{aligned} \text{Swept Friction Area} &= \frac{\text{Avg. hp}}{\text{hp absorption rate for 5 seconds (see page 160)}} \\ &= \frac{87 \text{ hp}}{0.43} = 202 \text{ in.}^2 \end{aligned}$$

$$\begin{aligned} \text{Torque} &= \frac{WR^2 \times \text{rpm}}{25.5 \times \text{Stop Time}} \\ &= \frac{2,473 \times 750}{25.5 \times 5} \\ &= 14,547 \text{ lb.in.} \end{aligned}$$

Using the above calculations, consult the Low Inertia Specifications Chart on pages 34 and 35.

Summary

As calculated, the torque required to stop the load in 5 seconds is 14,547 lb.in. Wichita Low Inertia Brakes are rated at 100 psi. This application has only 80 psi available.

To determine the torque rating of a Low Inertia brake at 80 psi apply the following formula:

Application: Torque for a Low Inertia Brake

$$\begin{aligned} &= \frac{\text{Torque} \times \text{Catalog Rated Pressure}}{\text{Available Air Pressure}} \\ &= 14,547 \times \frac{100}{80} = 18,183 \text{ lb.in.} \end{aligned}$$

Consult pages 34 and 35 for clutch and brake specifications. A Low Inertia model 114 Brake produces 27,625 lb.in. torque at 100 psi. However, the bore capacity is 4.125 inches. This application requires a 5 in. bore. Therefore, a Low Inertia 118 is to be investigated.

Catalog Torque Rating = 64,500 lb.in @ 100 psi
 Maximum Bore Capacity = 5.25 in.
 Catalog Swept Friction Area = 264 in.²

Calculations show this application needs at least 202 in.² to absorb the heat.

All of these ratings are acceptable for the given application data.

Next, check contact velocity of rotating discs.

$$\begin{aligned} &= \frac{\text{Diameter of centerplate} \times \text{rpm}}{3.82} \\ &= \frac{18" \times 750}{3.82} \\ &= 3,534 \text{ fpm} \end{aligned}$$

Standard material is sufficient up to 6,000 fpm (see page 31). Balancing is recommended above 3,500 fpm.

Therefore, a Low Inertia ATD-118 brake is the optimum choice for this application.

A Spring-Set Air Release Brake is also available (see page 54).

Note:

This application example is for preliminary sizing only. Contact a Wichita Sales Engineer or the factory for final selection.



Low Inertia and Very Low Inertia Clutches and Brakes

Specifications

Model Size ATD-	Slip Torque Lb. in at 100 PSI* .3 CF	Maximum Horsepower Per 100 RPM Duty				Max Bore Rect. Key Inches	Recommended Clearances Inches	Swept Friction Area-In ²
		A	B	C	D			
106	3,950	6.2	4.4	2.2	1.1	2	1/16-3/32	39
206	7,900	12.5	8.8	4.4	2.2	2	1/16-3/32	78
108	7,000	11.1	8	4	2	2-3/8	1/16-1/8	56
208	14,000	22.2	16	8	4	2-3/8	3/32-5/32	112
111	15,900	25	18	9	5	2-5/8	1/16-1/8	114
211	31,800	50	36	18	10	2-5/8	3/32-5/32	228
114	27,625	44	31	16	8	4-1/8	1/16-1/8	158
214	55,250	88	62	32	16	4-1/8	3/32-5/32	316
118	64,500	102	75	35	21	5-1/4	1/16-1/8	264
218	129,000	204	150	70	42	5-1/4	3/32-5/32	528
124H	153,700	243	180	90	40	7	3/32-5/32	574
224H	307,400	487	360	180	80	7	1/8-3/16	1,148
130H	327,000	519	380	190	100	8-1/2	3/32-5/32	827
230H	654,000	1038	760	380	200	8-1/2	1/8-3/16	1,654
136	508,000	805	600	295	165	10-1/2	3/32-5/32	1,150
236	1,016,000	1610	1200	590	330	10-1/2	1/8-3/16	2,300
142	726,000	1150	850	425	235	14	1/8-3/16	1,400
242	1,452,800	2300	1700	850	470	14	5/32-7/32	2,800
148	1,402,500	2225	1600	800	455	18	1/8-3/16	2,010
248	2,805,000	4450	3200	1600	915	18	5/32-7/32	4,020
260	5,950,000	9440	5950	3470	1940	19	3/16-5/16	7,230
360	8,925,000	14160	8925	5205	2910	19	1/4-3/8	10,845

*Max. recommended air pressure – 130 PSI.

Model No.	
Model Size	Model Type
ATD-xxx	LIC for Low Inertia Clutch
ATD-xxx	LIB for Low Inertia Brake
ATD-xxx	VLIC for Very Low Inertia Clutch
ATD-xxx	VLIB for Very Low Inertia Brake

Note: Very Low Inertia Clutches and Brakes are available in sizes from ATD-108 to ATD-224H.



Model Size ATD-	Low Inertia Clutches					Low Inertia Brakes			
	Total Wt. Lbs.	Total WR ² #Ft. ²	HUB & CP Wt. Lbs.	HUB & CP WR ² #Ft. ²	Effec. Wt. † Lbs.	Total Wt. Lbs.	HUB & CP Wt. Lbs.	HUB & CP WR ² #Ft. ²	Effect. Wt. † Lbs.
106	27.5	2.5	6.40	.24	5.67	25.5	6.40	.24	5.67
206	40.5	3.3	12.17	.46	10.01	38.5	12.17	.46	10.01
108	48.73	6.15	10.0	.55	8.50	46.23	10.0	.55	8.50
208	53.0	6.87	16.0	.72	11.0	50.5	16.0	.72	11.0
111	79.21	15.63	15.0	1.35	15.0	75.21	15.0	1.35	15.0
211	118.25	22.92	30.0	2.6	23.3	114.25	30.0	2.6	23.3
114	127	45	48	5.6	28.5	124	48	5.6	28.5
214	178	59	65	11	51.5	175	65	11	51.5
118	201	83	71	14.5	58	194	71	14.5	58
218	323	146	113	27.6	102	316	113	27.6	102
124H	504	399	131	50	120	496	131	50	120
224H	680	498	260	101	225	875	260	101	225
130H	685	922	212	129	178	643	212	129	178
230H	1146	1216	402	244	358	1004	402	244	358
136	1209	1842	351	325	364	1049	351	325	364
236	1822	2667	784	705	681	1642	784	705	681
142	1967	4721	680	705	438	1907	680	705	438
242	2732	5750	1197	1385	852	2528	1197	1385	852
148	3158	9325	1101	1785	779	3078	1101	1785	779
248	4700	13775	1942	3335	1465	4620	1942	3335	1465
260	9453	48733	2567	7077	3011	9261	2567	7077	3011
360	11643	57286	3870	10615	4373	11451	3870	10615	4373

Model Size ATD-	Very Low Inertia Clutches					Very Low Inertia Brakes			
	Total Wt. Lbs.	Total WR ² #Ft. ²	HUB & DP Wt. Lbs.	HUB & DP WR ² #Ft. ²	Effec. Wt. † Lbs.	Total Wt. Lbs.	HUB & DP Wt. Lbs.	HUB & DP WR ² #Ft. ²	Effect. Wt. † Lbs.
108	47.15	6.06	6.7	.24	11.53	44.85	6.7	.24	11.53
208	65.16	8.17	12.9	.44	19.06	62.66	12.9	.44	19.06
111	79.8	15.99	9.6	.59	21.8	75.8	9.6	.59	21.8
211	115.5	23.47	18.6	1.15	40.6	111.55	18.6	1.15	40.6
114	126	37.4	20.4	2.25	31.5	123	20.4	2.25	31.5
214	180	56.2	39.8	4.44	58.5	177	39.8	4.44	58.5
118	195.4	75.5	40.0	7.7	64	188.4	40.0	7.7	64
218	299.6	141.4	75.0	14.7	120	292.6	75.0	14.7	120
124H	471.5	377	84.0	28.5	155	463.5	84.0	28.5	155
224H	632	551	150	54.9	197	624	150	54.9	197

Air system data

PSI pressure

Inflation

Clutch air pressure during inflation can be closely estimated by the following:

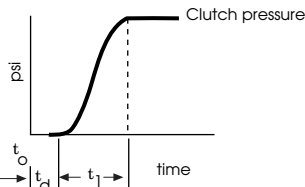

$$t_1 = \left(\frac{3}{K}\right)^{\frac{1}{U}} \text{sec.} = \text{Time to 95\% full inflation}$$

$$\text{Clutch pressure} = P_1 \left(1 - \frac{1}{e^{Kt^U}}\right) \text{psi}$$

(inflation)

This equation is accurate from 5% up to 95% P_1 .

P_1 = Line pressure to clutch psi

K and U = coefficients for specific clutch and air pressure from Specification Table

e = Napierian base log

t_o = Time at initiation of signal for inflation sec.

t_d = Time delay of air system – sec.

Exhaust

Clutch air pressure during exhaust can be closely estimated by the following:

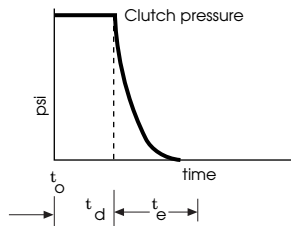

$$\text{Clutch pressure} = (P_1) (R) (E-t)^Y \text{psi}$$

(exhaust)

R, E and V = coefficients for specific clutch and air pressure from Specification Table.

t_e = Time to exhaust = E from Specification Table.

t = Time variable – seconds. In the exhaust equation “ t ” cannot exceed the value of “ E ” sec.

Overlap

A typical clutch-brake torque curve for a single backshaft press (cyclic application) would appear as shown below.

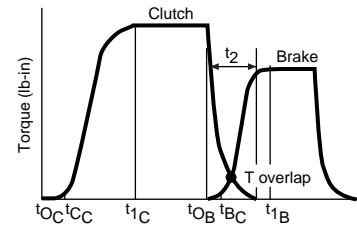

Time (sec.)

t_{oC} = time at which disengaged clutch receives signal

t_{cC} = time of clutch engagement

t_{1C} = time of clutch full inflation

t_{oB} = time at which disengaged brake receives signal

t_{Bc} = time of brake engagement

t_{1B} = time of brake full exhaust

t_2 = overlap time at which clutch and brake are both engaged

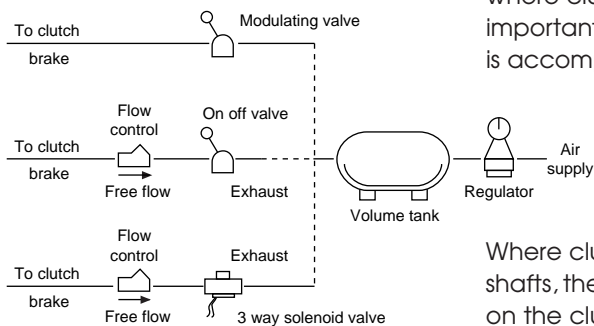

Shown are some of the air systems used on Wichita clutches. These systems are acceptable for remote operation where clutch reaction time is not important. Faster clutch reaction time is accomplished as indicated in the diagram by locating the flow control valve, if required, and the solenoid valve as close as possible to the roto-coupling.

Where clutches are located on long shafts, the use of quick release valves on the clutch will facilitate faster clutch response.

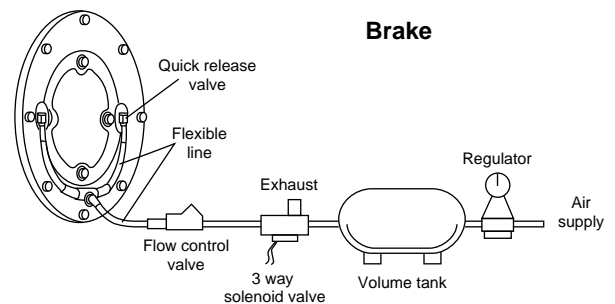
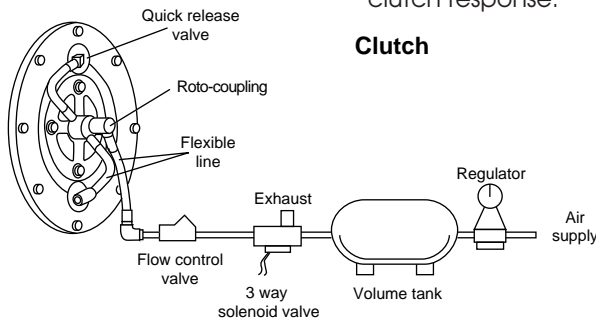

Low Inertia and Very Low Inertia Clutches and Brakes

Inflation Coefficients

Model Size ATD-	Inflation Coefficients Operating Air Pressure					
	50 PSI		75 PSI		100 PSI	
	K	U	K	U	K	U
108	15,800	2.2	7,100	2	265	1.2
208	15,800	2.2	7,100	2	265	1.2
111	890	1.7	880	1.6	5,100	2.2
211	890	1.7	880	1.6	5,100	2.2
114	980	2.3	980	2.3	980	2.3
214	980	2.3	980	2.3	980	2.3
118	9,600	3.1	1,560	2.4	9,600	3.1
218	9,600	3.1	1,560	2.4	9,600	3.1
124H	145	1.8	90	1.6	87	1.6
224H	145	1.8	90	1.6	87	1.6
130H	185	2	150	2	93	1.8
230H	185	2	150	2	93	1.8
136	170	2	250	2.2	160	2
236	170	2	250	2.2	160	2
142	115	2	125	2	111	2
242	115	2	125	2	111	2
148	25	1.6	22	1.6	26	1.8
248	25	1.6	22	1.6	26	1.8
260	28	1.8	22	1.8	20	1.8
360	28	1.8	22	1.8	20	1.8

Exhaust Coefficients

Model Size ATD-	Exhaust Coefficients Operating Air Pressure								
	50 PSI			75 PSI			100 PSI		
	R	E	V	R	E	V	R	E	V
108	60	.016	1.0	525	.02	1.6	240	.02	1.4
208	60	.016	1.0	525	.02	1.6	240	.02	1.4
111	1,000	.032	2	8,200	.04	2.8	4,930	.048	2.8
211	1,000	.032	2	8,200	.04	2.8	4,930	.048	2.8
114	720	.072	2.5	800	.069	2.5	1,840	.082	3
214	720	.072	2.5	800	.069	2.5	1,840	.082	3
118	44	.068	1.4	40	.072	1.4	34	.08	1.4
218	44	.068	1.4	40	.072	1.4	34	.08	1.4
124H	360	.096	2.5	240	.112	2.5	270	.136	2.8
224H	360	.096	2.5	240	.112	2.5	270	.136	2.8
130H	120	.104	2.1	140	.128	2.4	146	.158	2.7
230H	120	.104	2.1	140	.128	2.4	146	.158	2.7
136	124	.112	2.2	92	.128	2.2	76	.152	2.3
236	124	.112	2.2	92	.128	2.2	76	.152	2.3
142	132	.12	2.3	89	.144	2.3	61	.168	2.3
242	132	.12	2.3	89	.144	2.3	61	.168	2.3
148	20	.224	2	20	.256	2.2	19	.308	2.5
248	20	.224	2	20	.256	2.2	19	.308	2.5
260	24	.264	2.4	10	.367	2.3	9.9	.352	2.2
360	24	.264	2.4	10	.367	2.3	9.9	.352	2.2

Note: Very Low Inertia Clutches and Brakes are available in sizes from ATD-108 to ATD-224H. See page 34.

Low Inertia and Very Low Inertia Clutches and Brakes

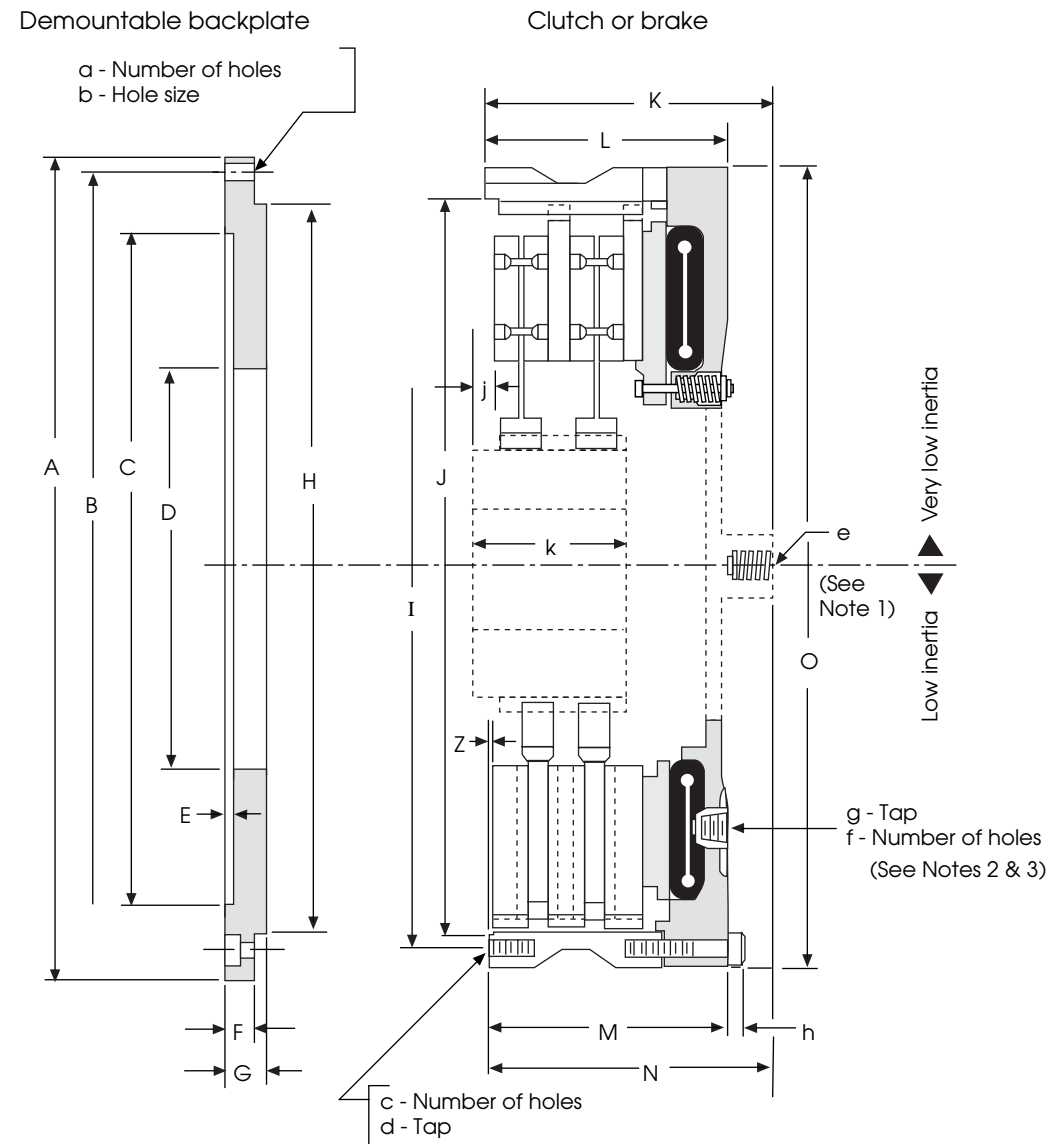

Notes:

1. Roto-couplings, see page 61.
2. Quick Release Valves, see page 61.
3. Air Hose Kits, see page 41.
4. VLI Drive Plates available with bonded or riveted pads.

Dimensions (in)

(Consult factory for drawing before final layout.)

Model Size ATD-	A	B	C	D	E	F	G	H	I	J	K	L
106	8.75	8.000	7.377/7.379	4.19	.06	.562	.69	7.373/7.375	8.000	7.377/7.379	—	—
206	8.75	8.000	7.377/7.379	4.19	.06	.562	.69	7.373/7.375	8.000	7.377/7.379	—	—
108	12.12	11.125	8.375/8.378	5.38	.25	.875	1.00	9.281/9.284	10.187	9.285/9.288	4.25	3.75
208	12.12	11.125	8.375/8.378	5.38	.25	.875	1.00	9.281/9.284	10.187	9.285/9.288	5.50	4.75
111	16.00	14.750	11.375/11.378	7.00	.38	1.125	1.25	12.370/12.373	13.500	12.375/12.378	5.50	3.75
211	16.00	14.750	11.375/11.378	7.00	.38	1.125	1.25	12.370/12.373	13.500	12.375/12.378	7.38	5.63
114	18.75	17.500	14.375/14.378	9.43	.38	1.125	1.25	15.121/15.124	16.250	15.125/15.128	6.25	4.75
214	18.75	17.500	14.375/14.378	9.43	.38	1.125	1.25	15.121/15.124	16.250	15.125/15.128	8.25	6.75
118	23.25	22.000	18.250/18.253	12.50	.38	1.125	1.25	19.495/19.498	20.750	19.500/19.503	6.69	5.19
218	23.25	22.000	18.250/18.253	12.50	.38	1.125	1.25	19.495/19.498	20.750	19.500/19.503	9.00	7.50
124H	30.00	28.750	24.375/24.378	14.50	.25	1.125	1.25	25.497/25.499	26.750	25.500/25.503	7.63	6.13
224H	30.00	28.750	24.375/24.378	14.50	.25	1.125	1.25	25.497/25.499	26.750	25.500/25.503	10.31	8.81
130H	37.00	35.500	30.375/30.378	19.25	.25	1.250	1.43	32.118/32.123	33.250	32.125/32.128	—	—
230H	37.00	35.500	30.375/30.378	19.25	.25	1.250	1.43	32.118/32.123	33.250	32.125/32.128	—	—
136	43.50	42.000	36.375/36.378	23.63	.25	1.500	1.75	38.120/38.123	39.500	38.125/38.128	—	—
236	43.50	42.000	36.375/36.378	23.63	.25	1.500	1.75	38.120/38.123	39.500	38.125/38.128	—	—
142	52.00	49.250	44.625/44.628	29.50	.25	1.500	1.75	44.995/44.998	46.500	45.000/45.003	—	—
242	52.00	49.250	44.625/44.628	29.50	.25	1.500	1.75	44.995/44.998	46.500	45.000/45.003	—	—
148	61.00	58.000	52.000/52.005	32.00	.25	1.500	1.75	51.993/51.998	54.000	52.000/52.005	—	—
248	61.00	58.000	52.000/52.005	32.00	.25	1.500	1.75	51.993/51.998	54.000	52.000/52.005	—	—
260	78.50	74.5000	59.990/60.000	35.50	.38	3.25	3.50	62.740/62.745	66.500	62.750/62.760	—	—
360	78.50	74.5000	59.990/60.000	35.50	.38	3.25	3.50	62.740/62.745	66.500	62.750/62.760	—	—

Model Size ATD-	M	N	O	Z	a	b	c	d	e	f	g	h	j	k
106	3.19	4.63	8.81	.06	4	11/32	4	5/16-18	5/8-18	2	1/4"NPT	.31	.69	2.00
206	4.38	5.81	8.81	.06	4	11/32	4	5/16-18	5/8-18		1/4"NPT	.31	.69	3.25
108	4.50	4.38	11.13	.13	6	17/32	6	1/2-13	1"-14	2	1/2" NPT	.50	.50	1.50
208	4.88	6.63	11.13	.13	6	17/32	6	1/2-13	1"-14		1/2" NPT	.50	.50	2.87
111	3.88	5.63	14.75	.13	6	21/32	6	5/8-11	1"-14	2	1/2" NPT	.63	.75	2.00
211	5.63	7.38	14.75	.13	6	21/32	6	5/8-11	1"-14		1/2" NPT	.63	.75	3.75
114	4.63	6.13	17.50	.13	8	21/32	8	5/8-11	1"-14	2	1/2" NPT	.63	.88	2.25
214	6.63	8.13	17.50	.13	8	21/32	8	5/8-11	1"-14		1/2" NPT	.63	.88	4.25
118	5.63	7.13	22.00	.13	12	21/32	12	5/8-11	1"-14	3	1/2" NPT	.63	.81	2.75
218	7.38	8.88	22.00	.13	12	21/32	12	5/8-11	1"-14		1/2" NPT	.63	.81	4.75
124H	5.88	7.38	29.00	.13	12	21/32	12	5/8-11	1"-14	3	1/2" NPT	.63	.56	3.13
224H	8.75	10.13	29.00	.13	12	21/32	12	5/8-11	1"-14		1/2" NPT	.63	.56	5.13
130H	7.88	9.38	34.75	.19	18	25/32	18	3/4-10	1"-14	4	1/2" NPT	.75	.88	4.00
230H	9.88	11.38	34.75	.19	18	25/32	18	3/4-10	1"-14		1/2" NPT	.75	.88	6.25
136	10.69	10.50	41.00	.19	18	25/32	18	3/4-10	1 1/2-12	4	1/2" NPT	.75	.88	4.25
236	11.75	12.44	41.00	.19	18	25/32	18	3/4-10	1 1/2-12		1/2" NPT	.75	.88	7.50
142	8.38	9.25	49.00	.25	24	1-1/32	24	1-8	1 1/2-12	4	1/2" NPT	1.00	.75	5.62
242	12.13	13.00	49.00	.25	24	1-1/32	24	1-8	1 1/2-12		1/2" NPT	1.00	.75	7.50
148	9.13	13.13	56.75	.25	24	1-1/32	24	1-8	1" NPT	4	1/2" NPT	1.00	1.00	6.00
248	13.43	17.43	56.75	.25	24	1-1/32	24	1-8	1" NPT		1/2" NPT	1.00	1.00	8.75
260	18.00	20.38	70.50	.25	24	2" NC	24	2-4-1/2	2-1/2"	6	1/2" NPT	2.00	1.00	9.37
360	23.00	25.00	70.50	.25	24	2" NC	24	2-4-1/2	2-1/2"		1/2" NPT	2.00	1.00	14.13

Notes: Very Low Inertia Clutches and Brakes are available in sizes from ATD-108 to ATD-224H. See page 34. For mounting, use socket head cap screws conforming to the ASTM-574-97a.

Low Inertia Clutches and Brakes Component Parts

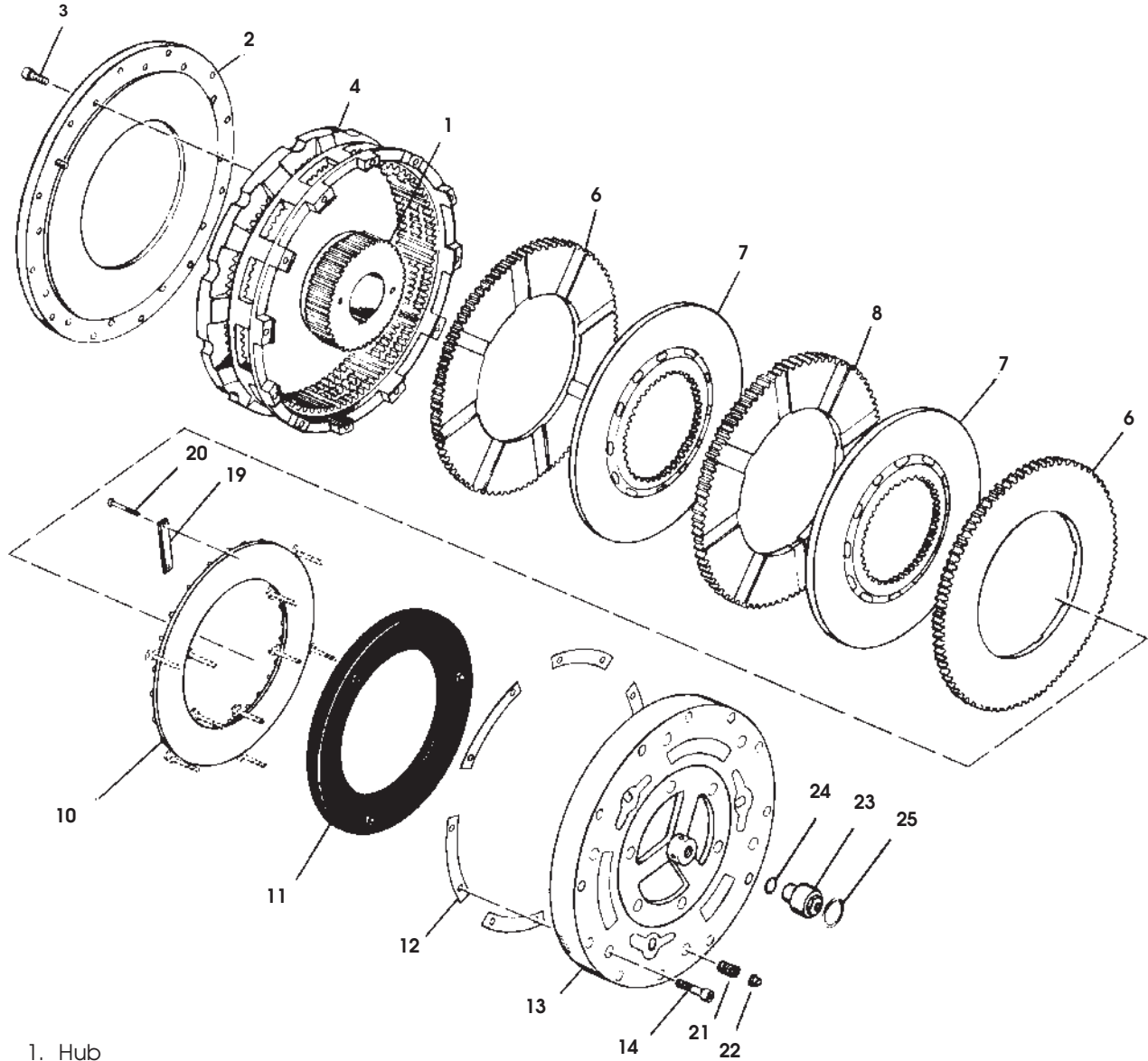

- | | | |
|---|---------------------------|---------------------|
| 1. Hub | 10. Pressure Plate | 21. Release Springs |
| 2. Demountable Back Plate | 11. Airtube | 22. Flexloc Nuts |
| 3. Socket Head Capscrews | 12. Shims | 23. Roto-coupling |
| 4. Ring | 13. Airtube Holding Plate | 24. "O" Ring |
| 6. Grooved Friction Disc
(grooved on one side) | 14. Socket Head Capscrews | 25. Snap Ring |
| 7. Center Plate | 19. Pressure Plate Lugs | |
| 8. Grooved Friction Disc
(grooved on both sides) | 20. Hex Head Capscrews | |



Air Hose Kits

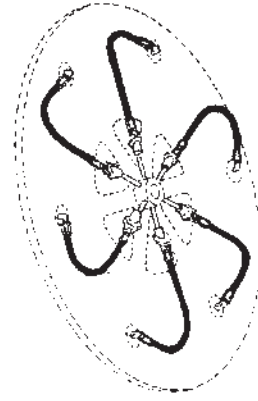
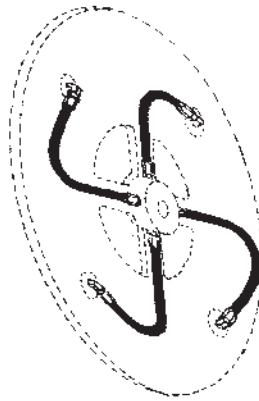
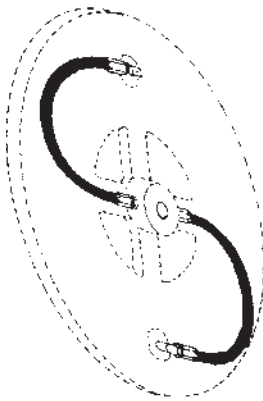

Size	Part Number
8"	8-908-812-200-5 8-908-821-201-5 QRV
11"	8-911-812-201-5 8-911-821-201-5 QRV
14"	8-914-812-200-5 8-914-821-200-5 QRV

Size	Part Number
18"	8-918-812-301-5 8-918-821-300-5 QRV
24"H	8-924-812-300-5 8-924-821-301-5 QRV

Size	Part Number
30"	8-930-812-400-5 8-930-821-400-5 QRV
36"	8-936-821-400-5 QRV
42"	8-942-821-400-5 QRV
48"	8-948-821-400-5 QRV

Size	Part Number
60"	8-960-800-500-7 QRV

Air hose kits contain all necessary parts (fittings, hoses and extensions) to completely plumb the clutch air system.

Optional Quick Release Valves can replace elbows on most units (see page 61).

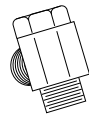

Roto-couplings (see page 61).

Distribuidor Autorizado e Importador - Arten Freios e Embreagens Ltda.
Fone: (11) 5594-8333 • Fax (11) 5589-2422 - arten@arten.com.br • www.arten.com.br

