

Clutch Coupling

SFC-120 Flange Mounted

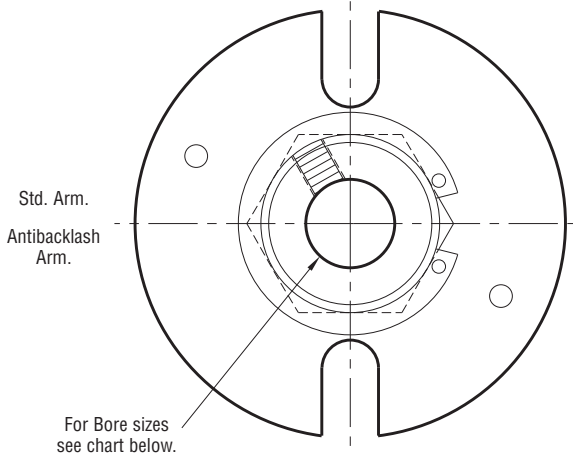

ARMATURE VIEW

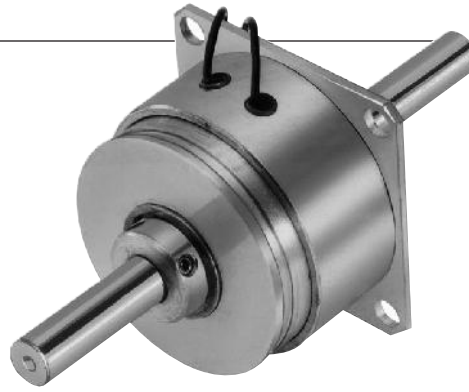
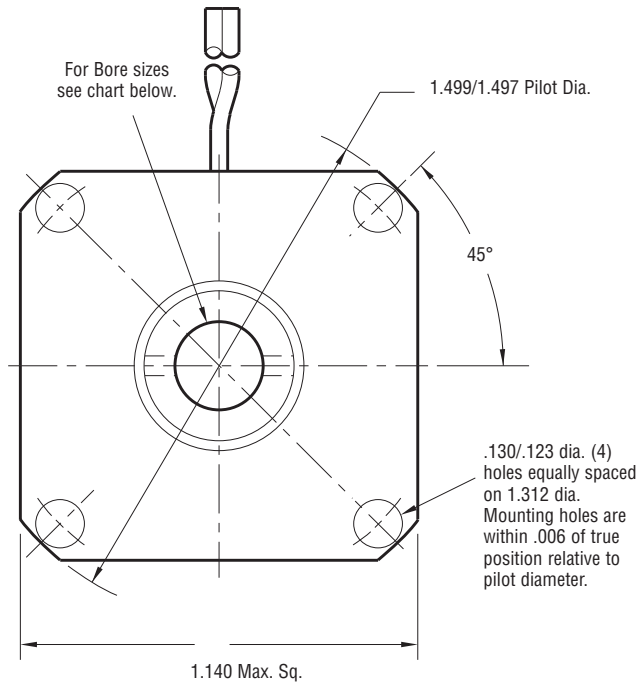

FIELD VIEW

Customer Shall Maintain:

1. Squareness of field mounting face with rotor shaft within .003 T.I.R. measured at pilot diameter
2. Concentricity of field mounting pilot diameter with rotor mounting shaft within .003 T.I.R.
3. Rotor and armature shafts in line within .003 T.I.R.

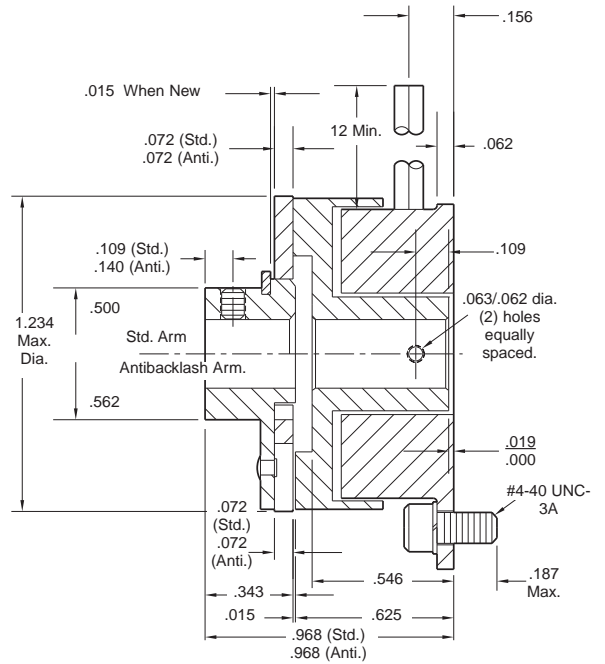

Bore Dimensions

Rotor Bore Dia.	Armature Bore Dia.
.188/.187	.188/.187
.251/.250	.251/.250
.313/.312	(.313/.312)*

*(Antibacklash Armatures)

Static Torque	5 lb. in.
Maximum Speed	3,600 rpm
Standard Voltage	D.C. 6, 24, 90

All dimensions are nominal unless otherwise noted.

Information on inertia and weights begins on page 239. Coil data is on pages 250 and 251.

Drawing I-25503

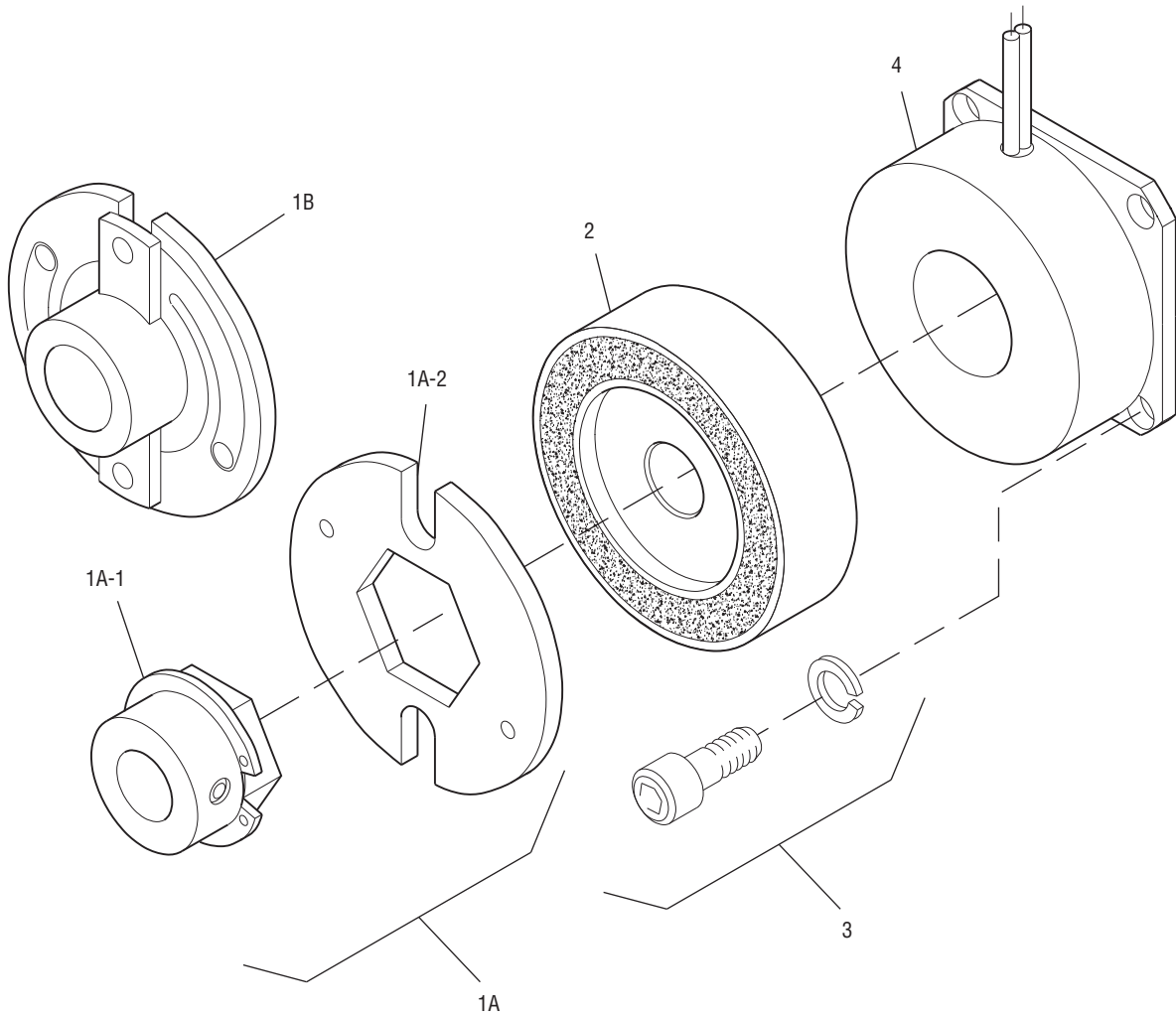

Item	Description	Part Number	Qty.
1A	Armature and Hub		
1A-1	Armature Hub		1
	3/16" Bore	5622-541-009	
	1/4" Bore	5622-541-008	
1A-2	Armature	110-0110	1
1B	Antibacklash Armature		1
	3/16" Bore	5622-111-004	
	1/4" Bore	5622-111-002	
	5/16" Bore	5622-111-003	
2	Rotor		1
	3/16" Bore	5602-751-004	
	1/4" Bore	5602-751-002	
	5/16" Bore	5602-751-003	
3	Mounting Accessory	5101-101-001	1
4	Field		1
	6 Volt	5602-451-003	
	24 Volt	5602-451-005	
	90 Volt	5602-451-007	

How to Order:

1. Specify Type of Armature Desired.
2. Specify Bore Size for Item 1A-1 or 1B and Item 2.
3. Specify Voltage for Item 4.
4. See Controls Section.

Example:

SFC-120 Clutch per I-25503 - 90 Volt
 Standard Armature
 1/4" Armature Hub Bore
 1/4" Rotor Bore

These units meet standards set forth in UL508 and are listed under guide card #NMTR2, file #59164.

These units are CSA certified under file #LR11543.

Refer to Service Manual P-200.

Clutch Coupling

SFC-120 Bearing Mounted

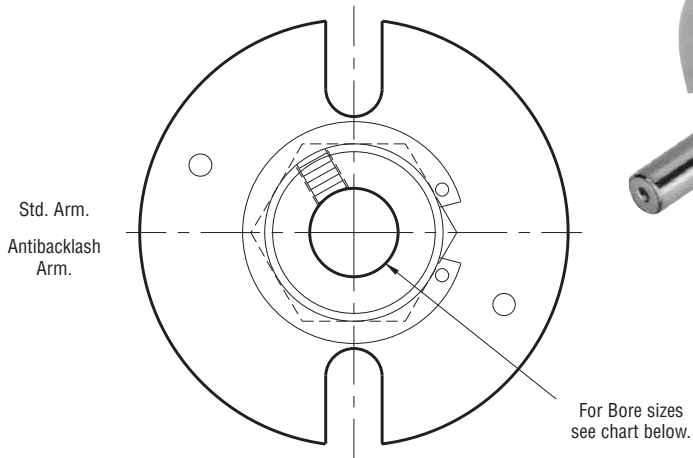
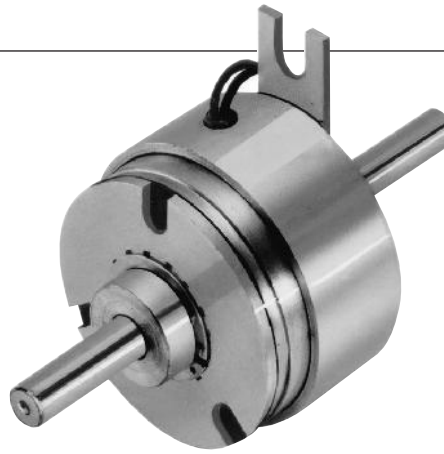

ARMATURE VIEW

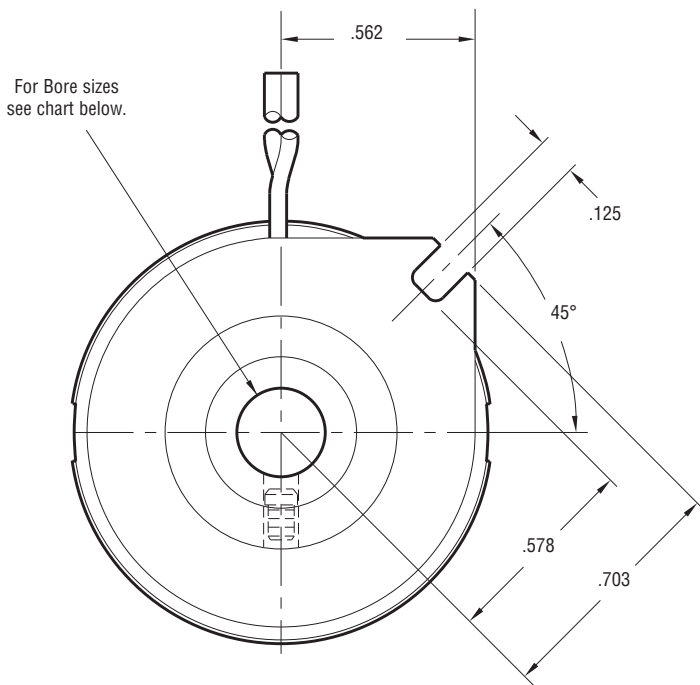

FIELD VIEW

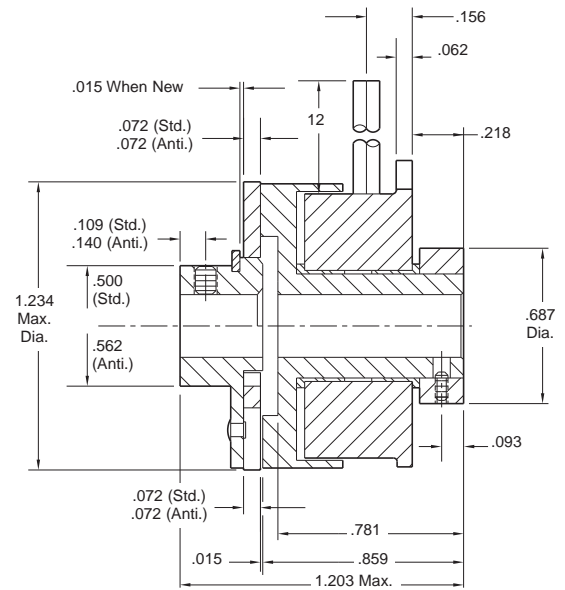

Bore Dimensions

Rotor Bore Dia.	Armature Bore Dia.
.188/.187	.188/.187
.251/.250	.251/.250
.313/.312	(.313/.312)*

*(Antibacklash Armatures)

Static Torque	5 lb. in.
Maximum Speed	3,600 rpm
Standard Voltage	D.C. 6, 24, 90

All dimensions are nominal unless otherwise noted.

Information on inertia and weights begins on page 239. Coil data is on pages 250 and 251.

Customer Shall Maintain:

1. Alignment between rotor and armature shafts to be .003 T.I.R.



Drawing I-25504

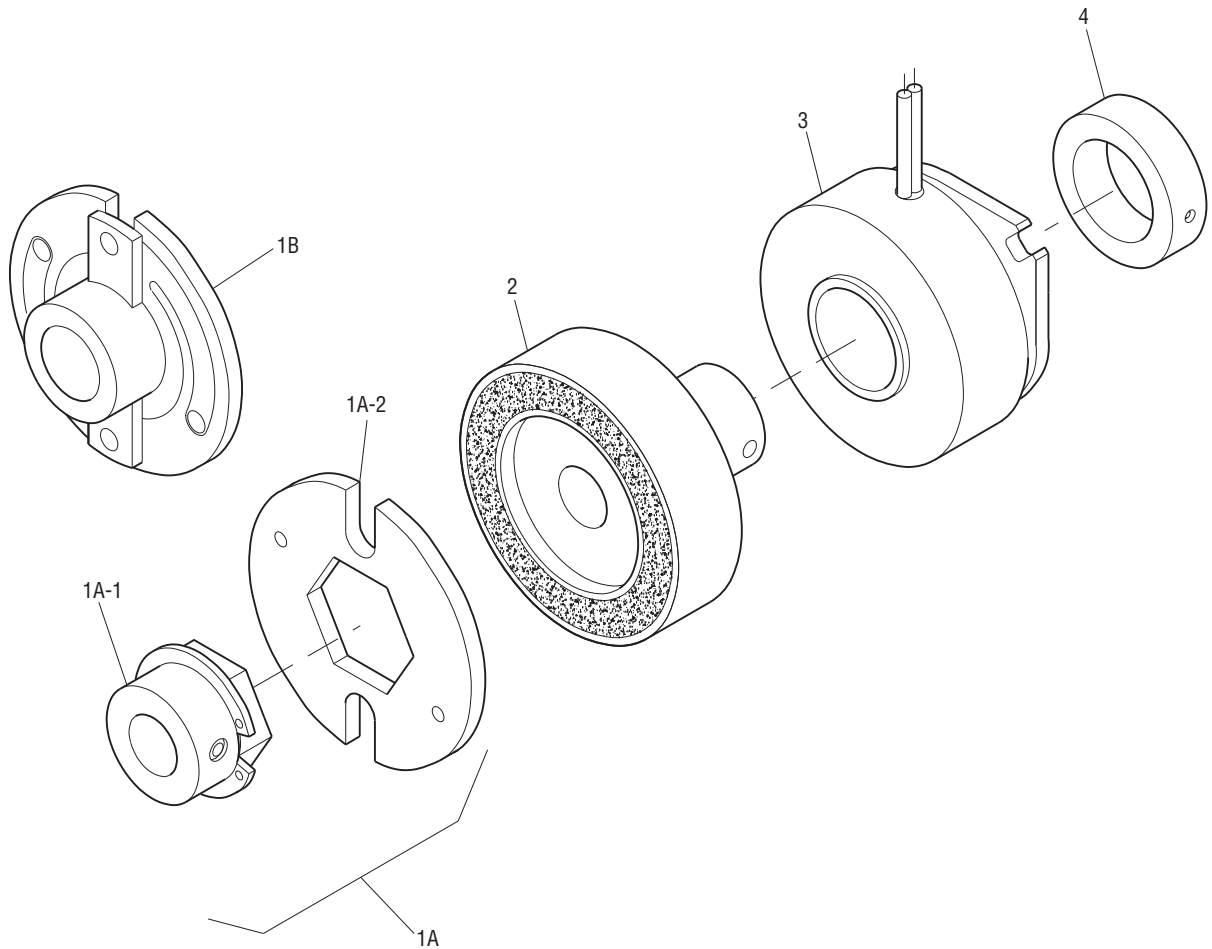

Item	Description	Part Number	Qty.
1A	Armature and Hub		
1A-1	Armature Hub		1
	3/16" Bore	5622-541-009	
	1/4" Bore	5622-541-008	
1A-2	Armature	110-0110	1
1B	Antibacklash Armature		1
	3/16" Bore	5622-111-004	
	1/4" Bore	5622-111-002	
	5/16" Bore	5622-111-003	
2	Rotor		1
	3/16" Bore	5602-751-008	
	1/4" Bore	5602-751-006	
	5/16" Bore	5602-751-007	
3	Field		1
	6 Volt	5602-451-021	
	24 Volt	5602-451-023	
	90 Volt	5602-451-025	
4	Set Collar	5602-266-001	1

How to Order:

1. Specify Type of Armature Desired.
2. Specify Bore Size for Item 1A-1 or 1B and Item 2.
3. Specify Voltage for Item 3.
4. See Controls Section.

Example:

SFC-120 Clutch per I-25504 - 90 Volt
 Standard Armature
 1/4" Armature Hub Bore

These units meet standards set forth in UL508 and are listed under guide card #NMTR2, file #59164.

These units are CSA certified under file #LR11543.

Refer to Service Manual P-200.

Clutch Coupling

SFC-170 Flange Mounted

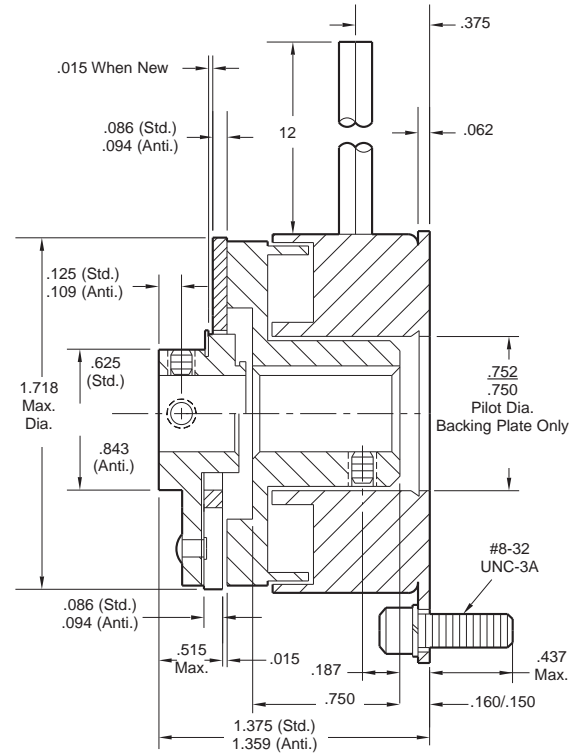
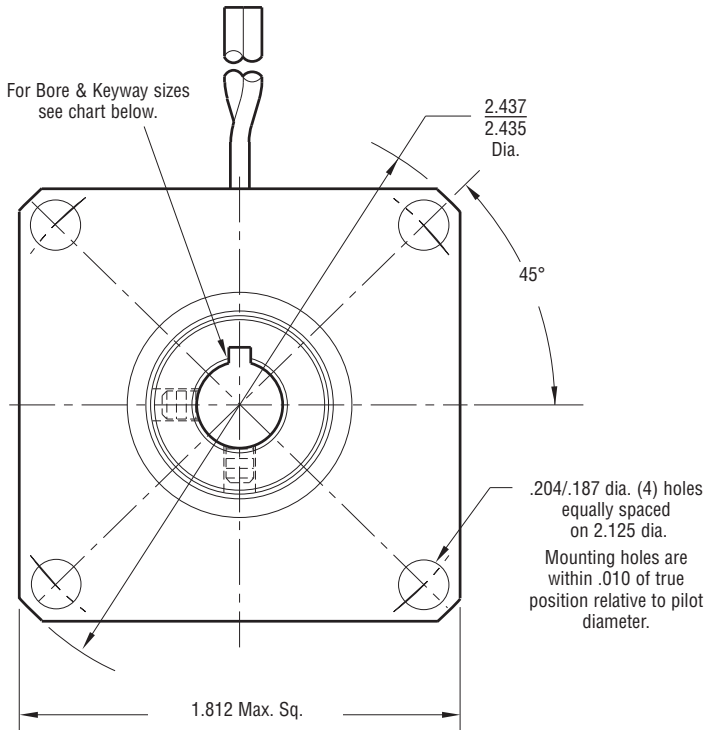
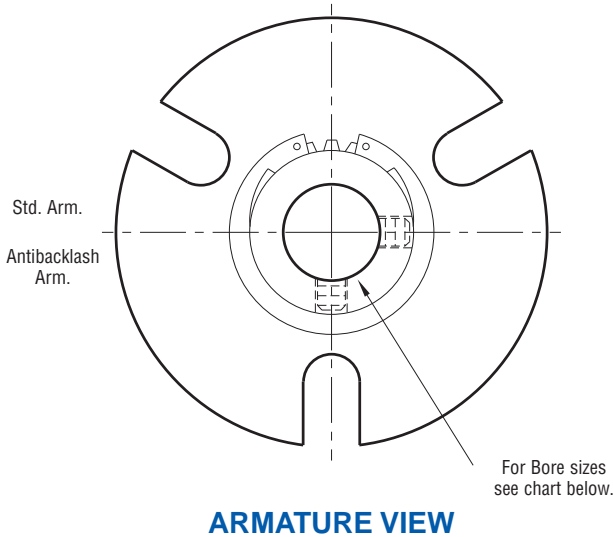
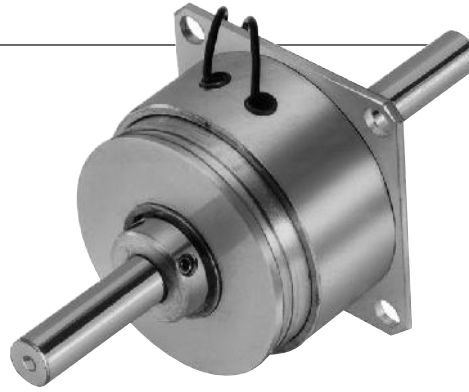

Bore Dimensions

Rotor Bore Dia.	Keyway	Armature Bore Dia.
.251/.250	.062 x .031	.251/.250
.313/.312	.062 x .031	.313/.312
.376/.375	.093 x .046	.376/.375

Static Torque	15 lb. in.
Maximum Speed	5,000 rpm
Standard Voltage	D.C. 6, 24, 90

All dimensions are nominal unless otherwise noted.

Information on inertia and weights begins on page 239. Coil data is on pages 250 and 251.

Customer Shall Maintain:

1. Squareness of field mounting face with rotor shaft within .003 T.I.R. measured at pilot diameter
2. Concentricity of field mounting pilot diameter with rotor mounting shaft within .003 T.I.R.
3. Rotor and armature shafts in line within .003 T.I.R.



Drawing I-25756

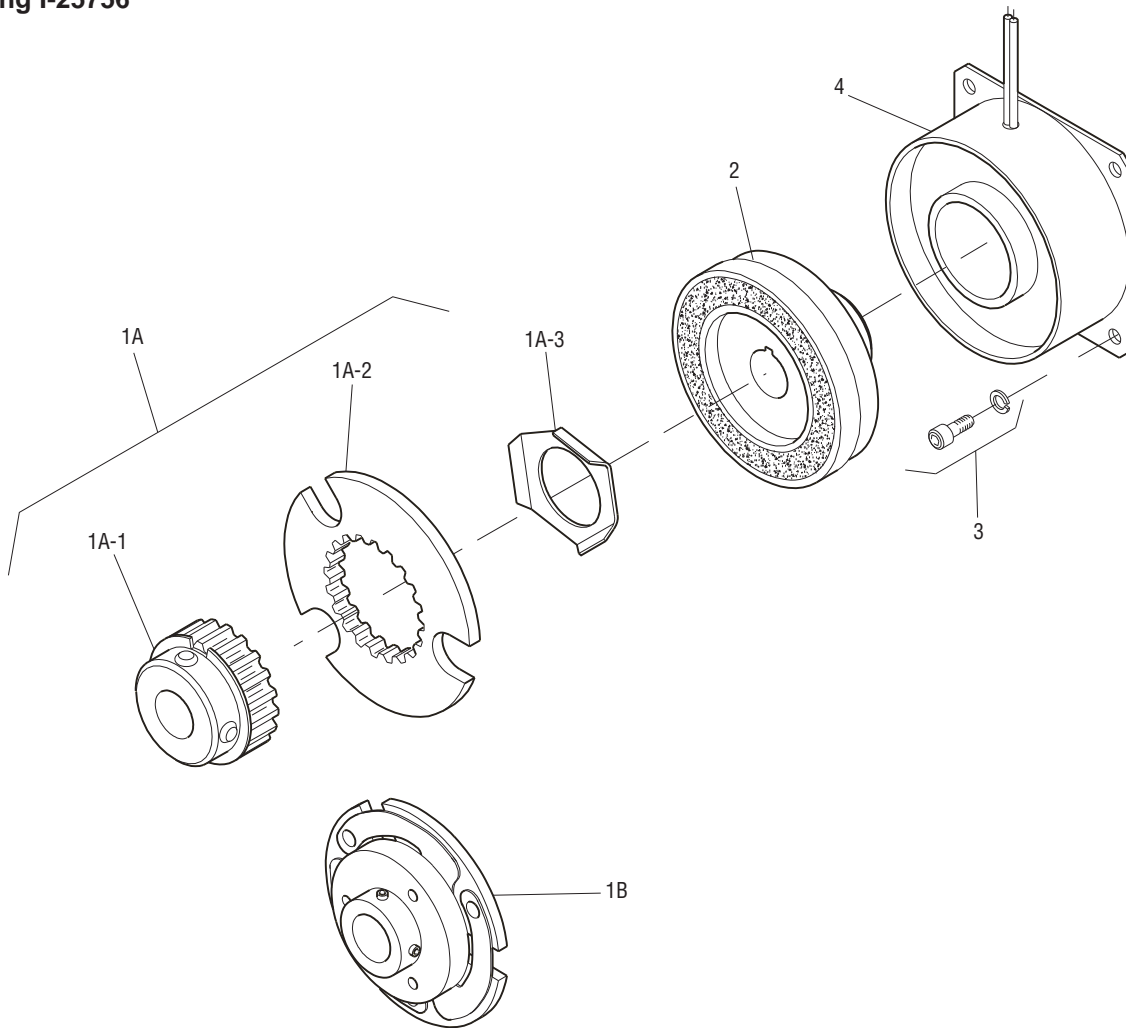

Item	Description	Part Number	Qty.
1A	Armature and Hub		
1A-1	Armature Hub		1
	1/4" Bore	5102-541-002	
	5/16" Bore	5102-541-003	
	3/8" Bore	5102-541-004	
1A-2	Armature	110-0111	1
1A-3	Release Spring	808-0019	1
1B	Antibacklash Armature		1
	1/4" Bore	5623-111-008	
	5/16" Bore	5623-111-009	
	3/8" Bore	5623-111-010	
2	Rotor		1
	1/4" Bore	5603-751-028	
	5/16" Bore	5603-751-029	
	3/8" Bore	5603-751-030	
3	Mounting Accessory	5102-101-001	1
4	Field		1
	6 Volt	5603-451-047	
	24 Volt	5603-451-049	
	90 Volt	5603-451-051	

How to Order:

1. Specify Type of Armature Desired.
2. Specify Bore Size for Item 1A-1 or 1B and Item 2.
3. Specify Voltage for Item 4.
4. See Controls Section.

Example:

SFC-170 Clutch per I-25756 - 90 Volt
 Antibacklash Armature
 1/4" Armature Hub Bore
 1/4" Rotor Bore

These units meet standards set forth in UL508 and are listed under guide card #NMTR2, file #59164.

These units are CSA certified under file #LR11543.

Refer to Service Manual P-200.

Clutch Coupling

SFC-170 Bearing Mounted

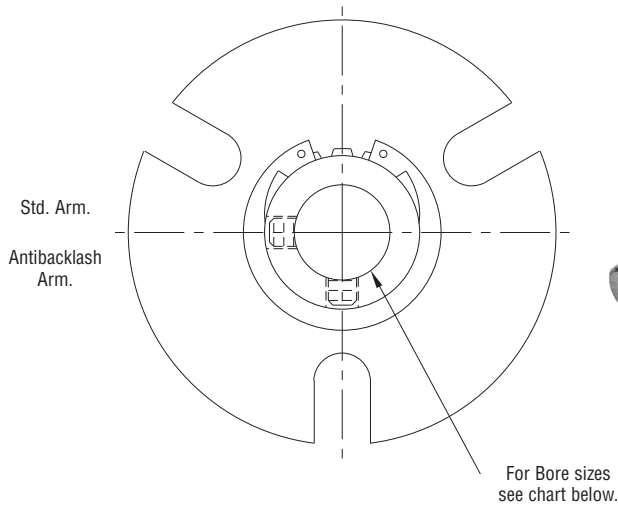
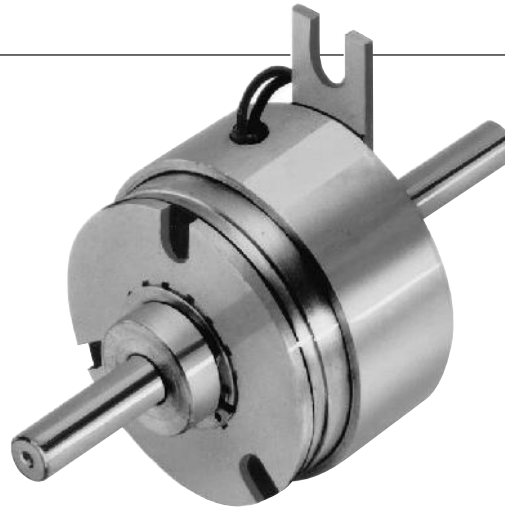

ARMATURE VIEW

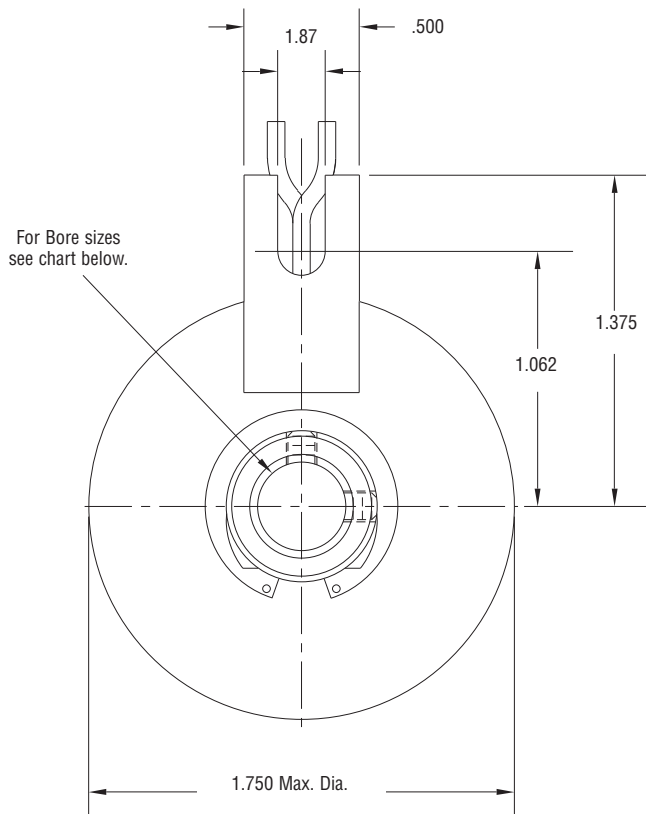

FIELD VIEW

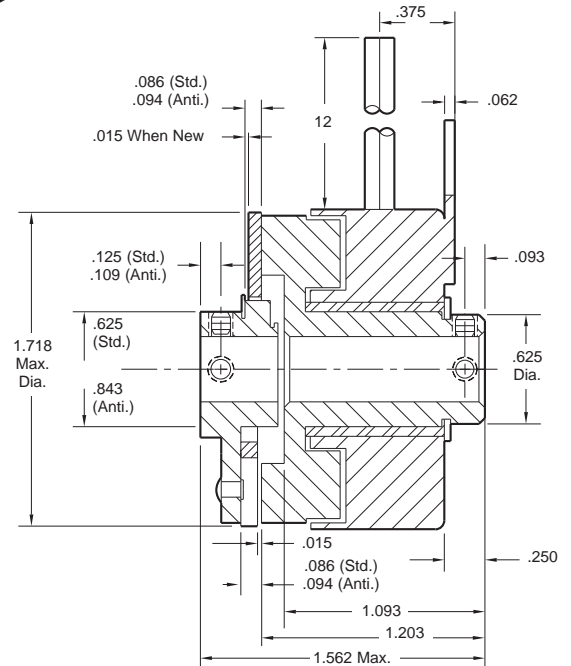

Bore Dimensions

Rotor Bore Dia.	Armature Bore Dia.
.251/.250	.251/.250
.313/.312	.313/.312
.376/.375	.376/.375

Static Torque	15 lb. in.
Maximum Speed	5,000 rpm
Standard Voltage	D.C. 6, 24, 90

Customer Shall Maintain:

1. Alignment between rotor and armature shafts to be .003 T.I.R.

All dimensions are nominal unless otherwise noted.

Information on inertia and weights begins on page 239. Coil data is on pages 250 and 251.



Drawing I-25757

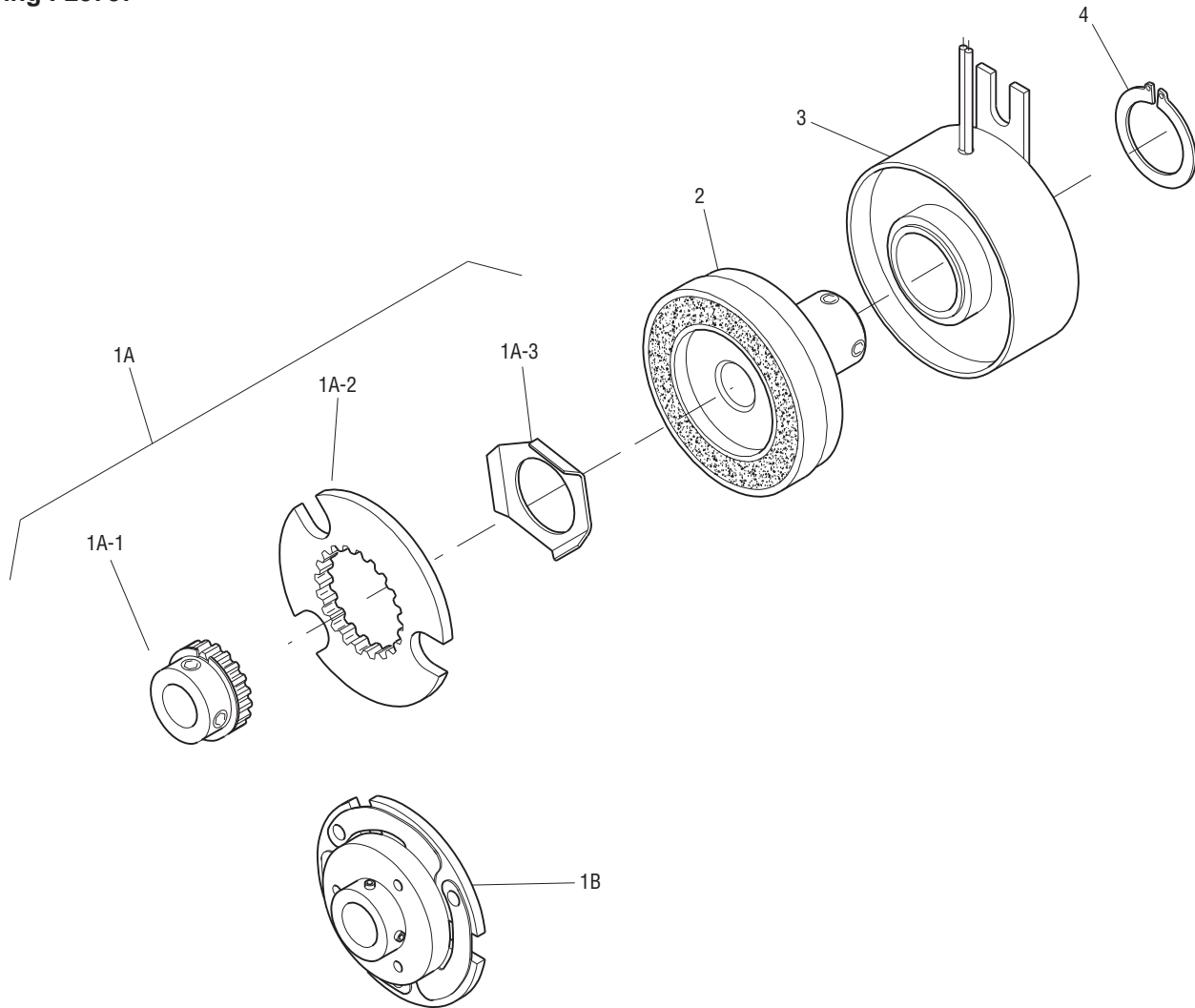

Item	Description	Part Number	Qty.
1A	Armature and Hub		
1A-1	Armature Hub		1
	1/4" Bore	5102-541-002	
	5/16" Bore	5102-541-003	
	3/8" Bore	5102-541-004	
1A-2	Armature	110-0111	1
1A-3	Release Spring	808-0019	1
1B	Antibacklash Armature		1
	1/4" Bore	5623-111-008	
	5/16" Bore	5623-111-009	
	3/8" Bore	5623-111-010	
2	Rotor		1
	1/4" Bore	5603-751-019	
	5/16" Bore	5603-751-021	
	3/8" Bore	5603-751-020	
3	Field		1
	6 Volt	5603-451-039	
	24 Volt	5603-451-041	
	90 Volt	5603-451-043	

Item	Description	Part Number	Qty.
4	Retainer Ring	748-0024	1

How to Order:

1. Specify Type of Armature Desired.
2. Specify Bore Size for Item 1A-1 or 1B and Item 2.
3. Specify Voltage for Item 3.
4. See Controls Section.

Example:

SFC-170 Clutch per I-25757 - 90 Volt
Antibacklash Armature
1/4" Armature Hub Bore

These units meet standards set forth in UL508 and are listed under guide card #NMTR2, file #59164.

These units are CSA certified under file #LR11543.

Refer to Service Manual P-200.

Clutch Coupling

SFC-250 Flange Mounted



For Bore & Keyway sizes see chart below.

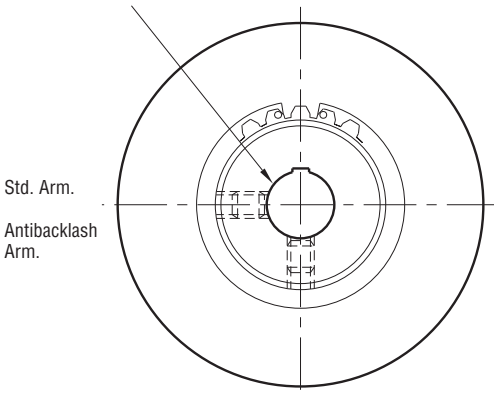

ARMATURE VIEW

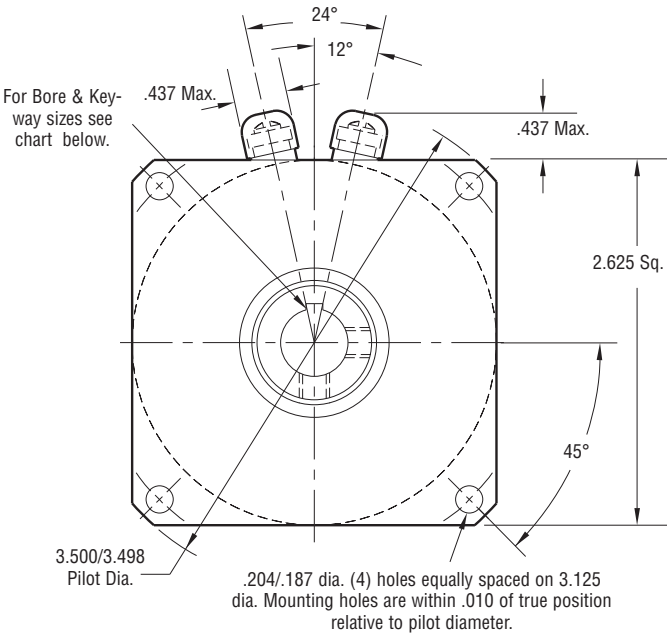

FIELD VIEW

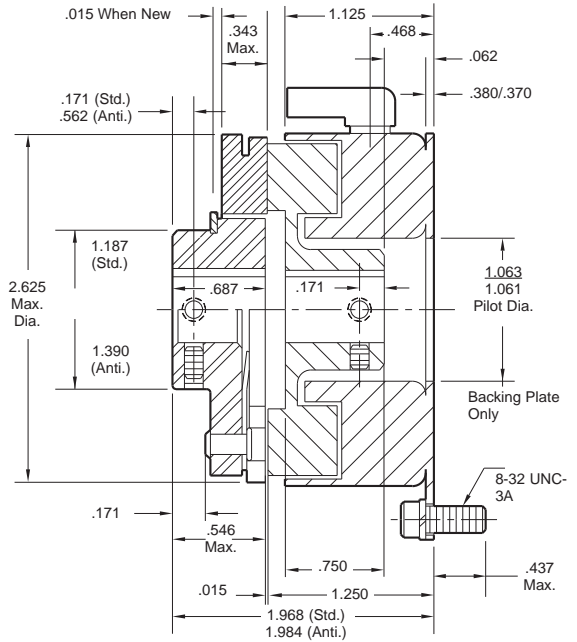

Bore and Keyway Dimensions

Armature Bore Dia.	Keyway	Rotor Bore Dia.	Keyway
.376/.375	.093 x .046		
*.438/.437		.376/.375	.093 x .046
.501/.500	.125 x .062	*.438/.437	.125 x .062
*.563/.562		.501/.500	
.626/.625			
*.688/.687	.187 x .093		
.751/.750			

* Available on special order only.

Customer Shall Maintain:

1. Squareness of field mounting face with rotor shaft within .003 T.I.R. measured at pilot diameter.
2. Concentricity of field mounting pilot diameter with rotor mounting shaft within .003 T.I.R.
3. Rotor and armature shafts in line within .003 T.I.R.

Static Torque	70 lb. in.
Maximum Speed	7,500 rpm
Standard Voltage	D.C. 6, 24, 90

All dimensions are nominal unless otherwise noted.

Information on inertia and weights begins on page 239. Coil data is on pages 250 and 251.



Drawing I-25522

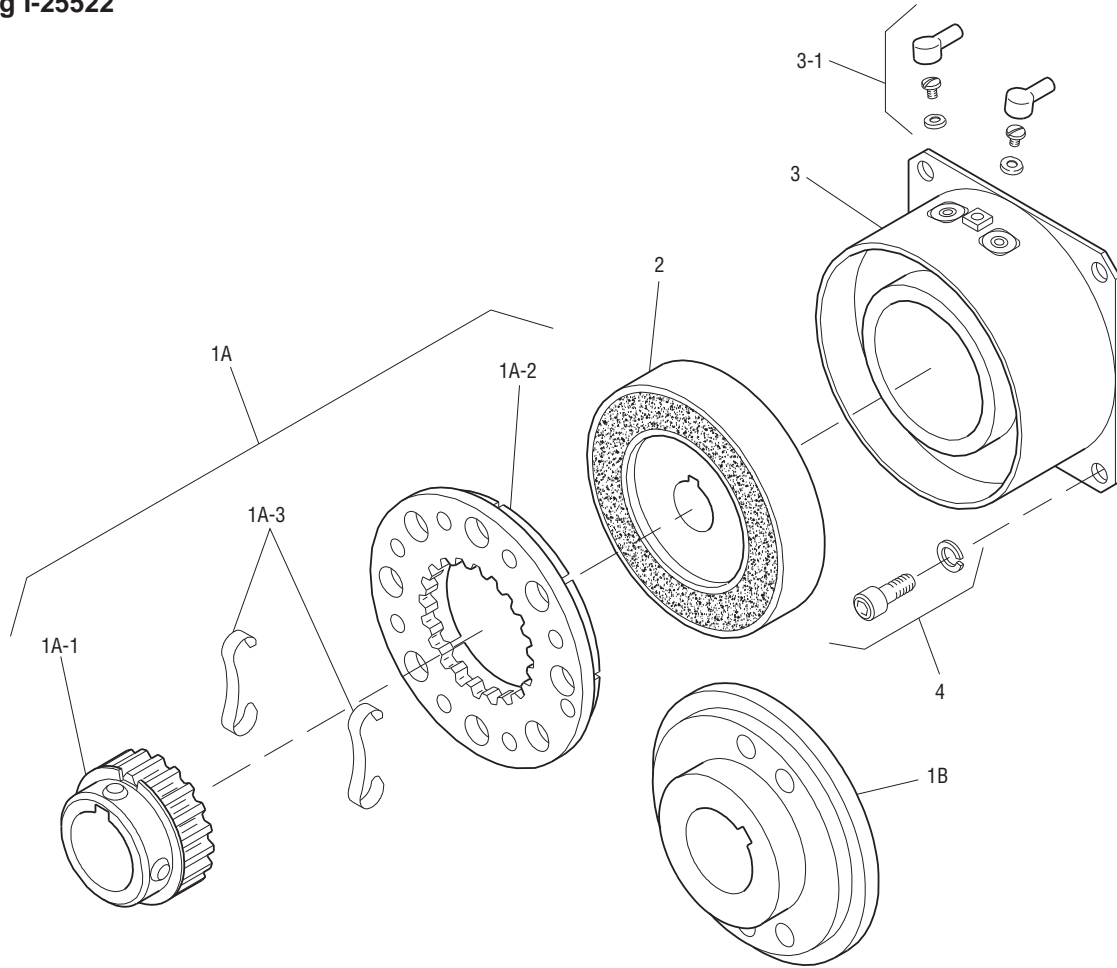

Item	Description	Part Number	Qty.
1A	Armature and Hub		
1A-1	Armature Hub		1
	3/8" Bore	5103-541-002	
	1/2" Bore	5103-541-004	
	5/8" Bore	5103-541-006	
	3/4" Bore	5103-541-008	
1A-2	Armature	5124-111-001	1
1A-3	Release Spring	5103-101-003	1
1B	Antibacklash Armature		1
	3/8" Bore	5365-111-003	
	1/2" Bore	5365-111-005	
	5/8" Bore	5365-111-007	
	3/4" Bore	5365-111-009	
2	Rotor		1
	3/8" Bore	5103-751-008	
	1/2" Bore	5103-751-010	
3	Field		1
	6 Volt	5103-451-002	
	24 Volt	5103-451-004	
	90 Volt	5103-451-007	

Item	Description	Part Number	Qty.
3-1	Terminal Accessory	5103-101-002	1
4	Mounting Accessory	5102-101-001	1

How to Order:

1. Specify Type of Armature Desired.
2. Specify Bore Size for Item 1A-1 or 1-B and Item 2.
3. Specify Voltage for Item 3.
4. See Controls Section.

Example:

SFC-250 Clutch Coupling per I-25522 - 90 Volt
 Standard Armature
 1/2" Armature Hub Bore
 1/2" Rotor Bore

These units meet standards set forth in UL508 and are listed under guide card #NMTR2, file #59164.

These units are CSA certified under file #LR11543.

Refer to Service Manual P-200.

Clutch Coupling

SFC-250 Bearing Mounted



For Bore & Keyway sizes see chart below.

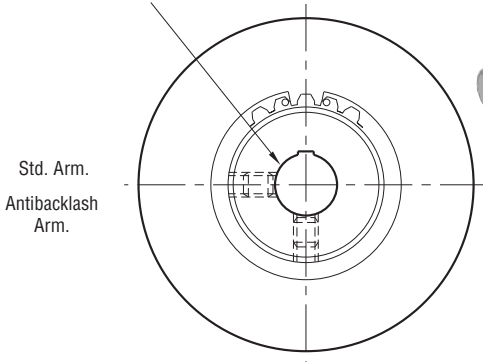

ARMATURE VIEW

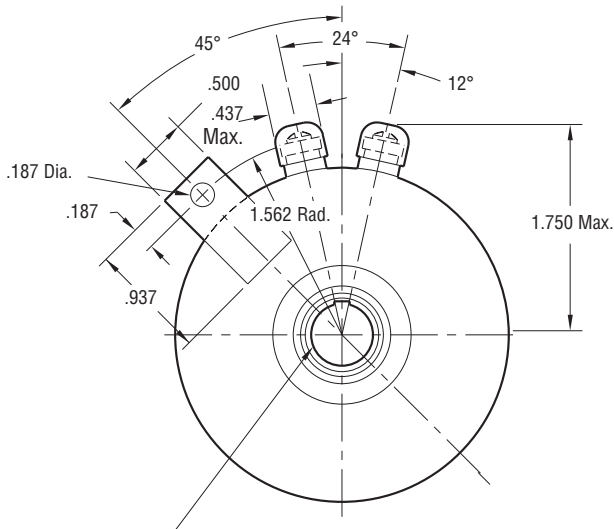

For Bore & Keyway sizes see chart below.

FIELD VIEW

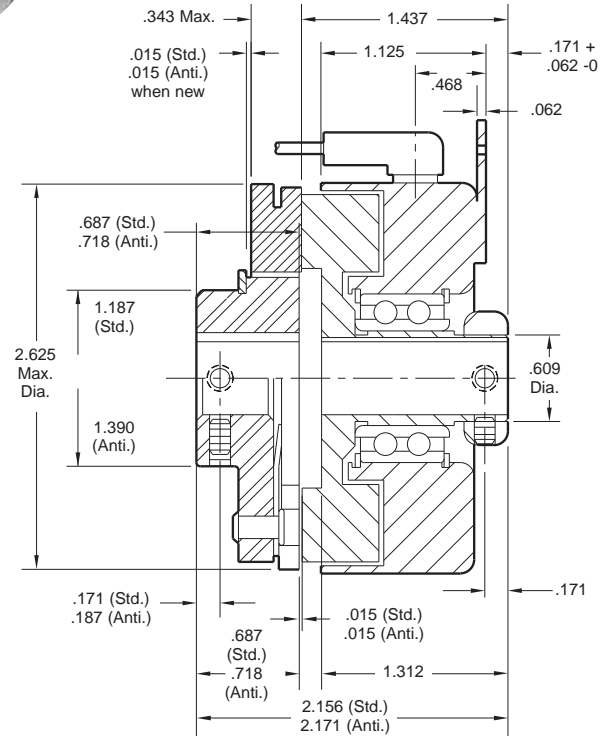

Bore and Keyway Dimensions

Armature Bore Dia.	Keyway	Rotor Bore Dia.	Keyway
.375/.376	.093 x .046	.376/.375	.093 x .046
*.438/.437 .501/.500 .563/.562	.125 x .062	*.438/.437 .501/.500	.125 x .062
.626/.625 *.688/.687 .751/.750	.187 x .093		

* Available on special order only.

Static Torque	70 lb. in.
Maximum Speed	7,500 rpm
Standard Voltage	D.C. 6, 24, 90

All dimensions are nominal unless otherwise noted.

Information on inertia and weights begins on page 239. Coil data is on pages 250 and 251.



Clutch Coupling

SFC-250 Bearing Mounted

Drawing I-25523

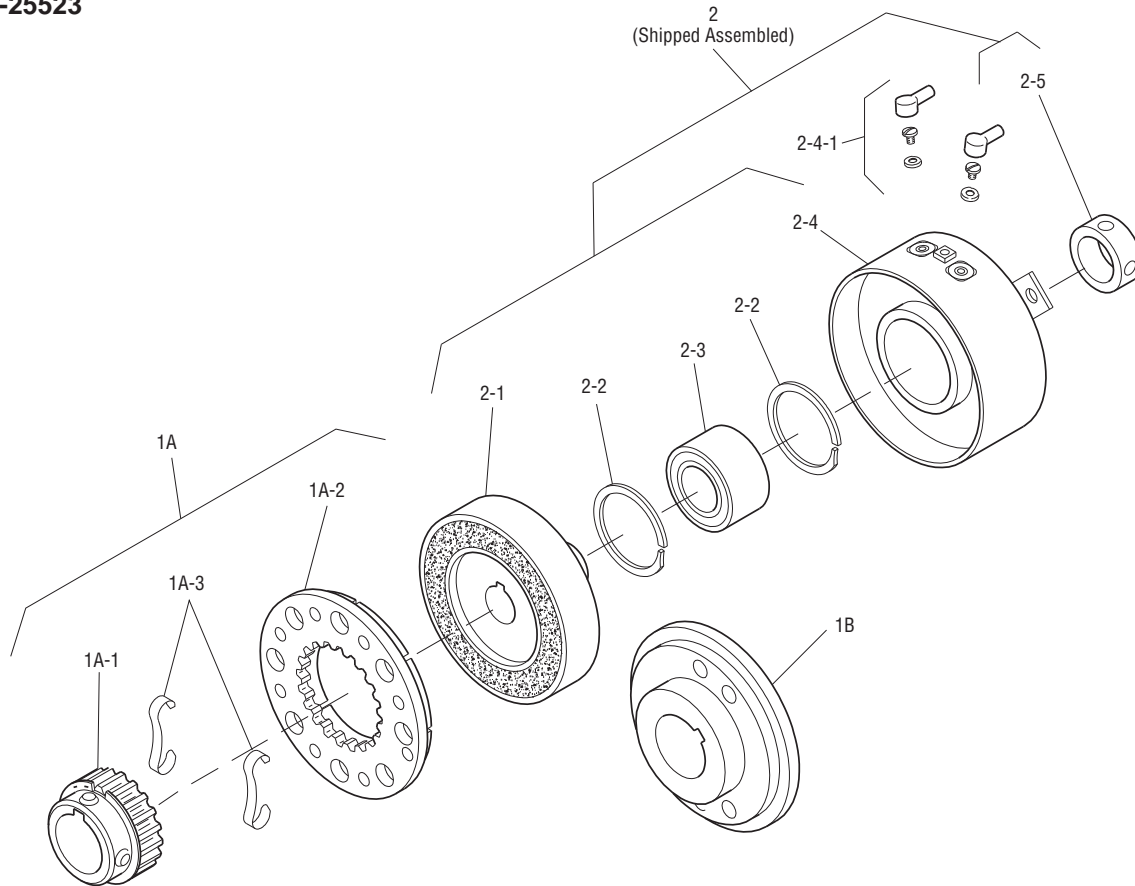

Item	Description	Part Number	Qty.
1A	Armature and Hub		
1A-1	Armature Hub		1
	3/8" Bore	5103-541-002	
	1/2" Bore	5103-541-004	
	5/8" Bore	5103-541-006	
	3/4" Bore	5103-541-008	
1A-2	Armature	5124-111-001	1
1A-3	Release Spring	5103-101-003	1
1B	Antibacklash Armature		1
	3/8" Bore	5365-111-003	
	1/2" Bore	5365-111-005	
	5/8" Bore	5365-111-007	
	3/4" Bore	5365-111-009	
2	Field and Rotor Assembly		1
	6 Volt - 3/8" Bore	5103-452-002	
	24 Volt - 3/8" Bore	5103-452-004	
	90 Volt - 3/8" Bore	5103-452-007	
	6 Volt - 1/2" Bore	5103-452-016	
	24 Volt - 1/2" Bore	5103-452-018	
	90 Volt - 1/2" Bore	5103-452-021	
2-1	Rotor		1
	3/8" Bore	5103-751-014	
	1/2" Bore	5103-751-016	

Item	Description	Part Number	Qty.
2-2	Retainer Ring	748-0371	2
2-3	Ball Bearing	166-0108	1
2-4	Field		1
	6 Volt	5103-451-018	
	24 Volt	5103-451-020	
	90 Volt	5103-451-023	
2-4-1	Terminal Accessory	5103-101-002	1
2-5	Set Collar*	266-0005	1

How to Order:

1. Specify Type of Armature Desired.
2. Specify Bore Size for Item 1A-1 or 1B and Item 2.
3. Specify Voltage for Item 2.
4. See Controls Section.

Example:

SFC-250 Clutch Coupling per I-25523 - 90 Volt
 Standard Armature
 1/2" Armature Hub Bore
 1/2" Rotor Bore

These units meet standards set forth in UL508 and are listed under guide card #NMTR2, file #59164. These units are CSA certified under file #LR11543.

*Used with 1/2" Bore only.

Refer to Service Manual P-200.

Clutch Coupling

SFC-400 Flange Mounted

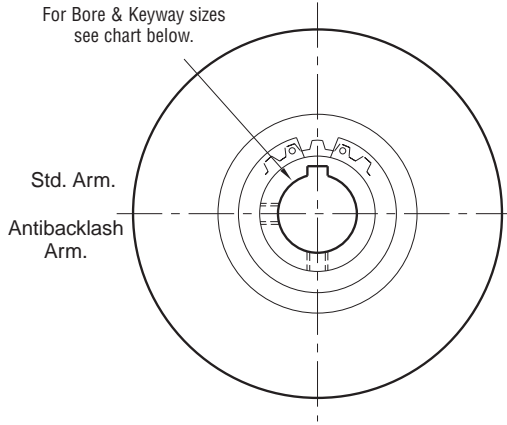

ARMATURE VIEW

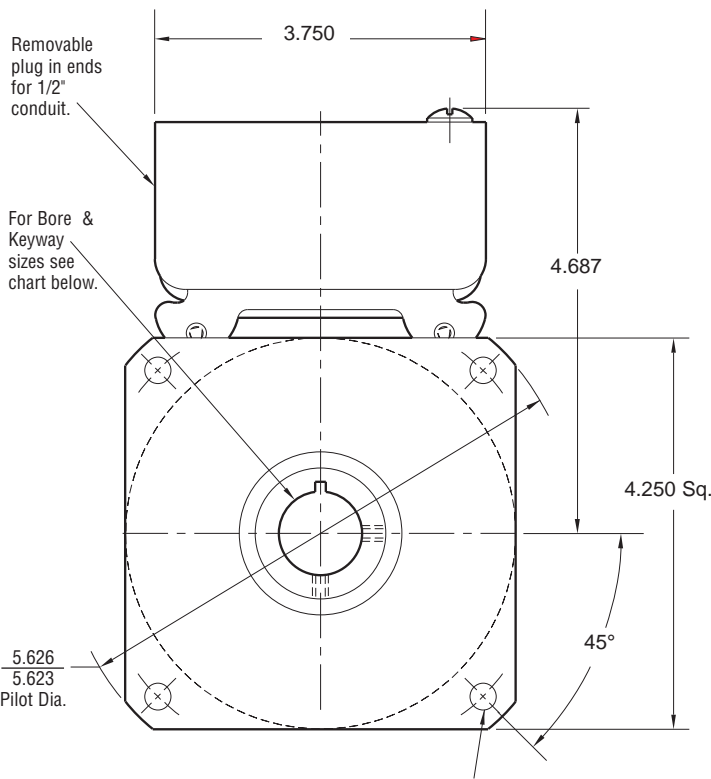

.296/.280 dia. (4) holes equally spaced on 5.000 dia.*

FIELD VIEW

*Mounting holes are within .010 of true position relative to pilot diameter.

Customer Shall Maintain:

1. Squareness of field mounting face with rotor shaft within .003 T.I.R. measured at pilot diameter.
2. Concentricity of field mounting pilot diameter with rotor mounting shaft within .003 T.I.R.
3. Rotor and armature shafts in line within .003 T.I.R.

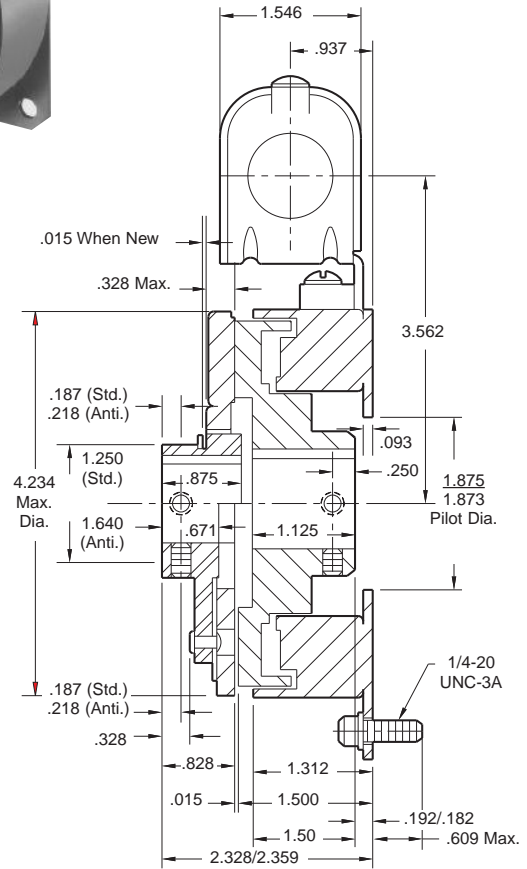

Bore and Keyway Dimensions

Armature Bore Dia.	Keyway	Rotor Bore Dia.	Keyway
.501/.500	.125 x .062	.501/.500	.125 x .062
*.563/.562			
.626/.625		.626/.625	
*.688/.687	.187 x .093	.751/.750	.187 x .093
.751/.750		.876/.875	
.876/.875		1.001/1.000	

*Available on special order only

Static Torque	270 lb. in.
Maximum Speed	4,500 rpm
Standard Voltage	D.C. 6, 24, 90

All dimensions are nominal unless otherwise noted.

Information on inertia and weights begins on page 239. Coil data is on pages 250 and 251.



Drawing I-25697

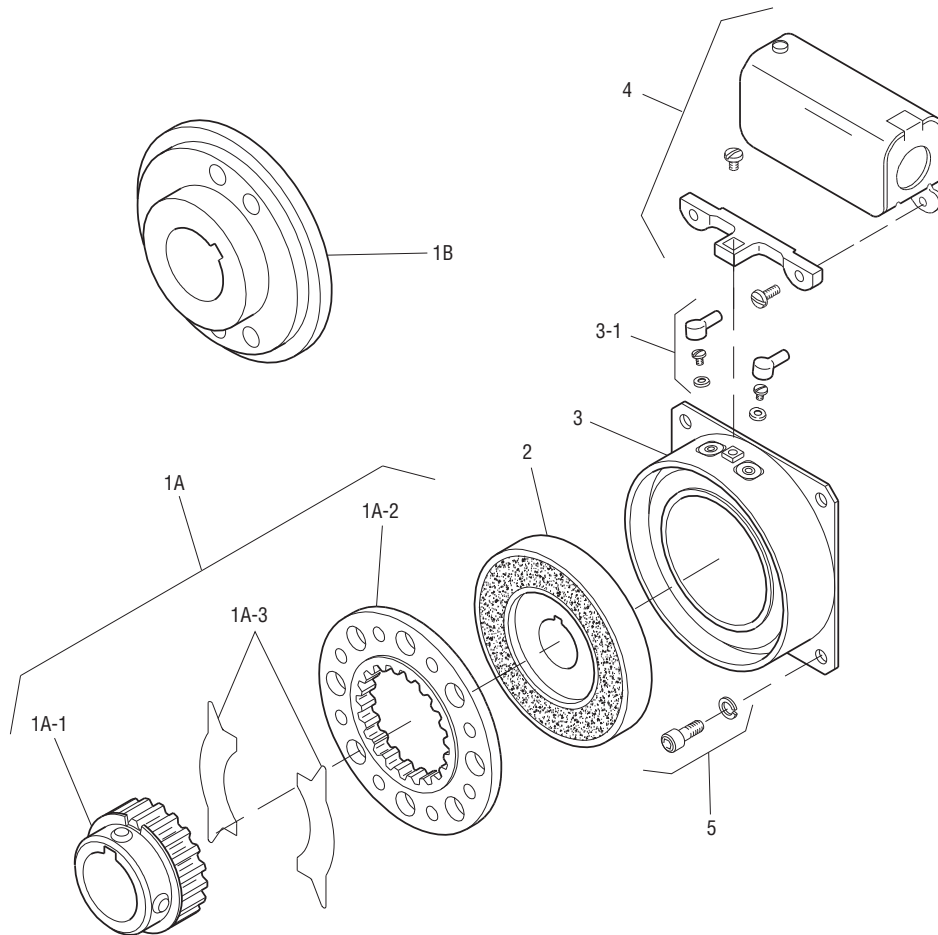

Item	Description	Part Number	Qty.
1A	Armature and Hub		
1A-1	Armature Hub		1
	1/2" Bore	5104-541-002	
	5/8" Bore	5104-541-004	
	3/4" Bore	5104-541-006	
	7/8" Bore	5104-541-007	
1A-2	Armature	5125-111-001	1
1A-3	Release Spring	5104-101-003	1
1B	Antibacklash Armature		1
	1/2" Bore	5367-111-003	
	5/8" Bore	5367-111-005	
	3/4" Bore	5367-111-007	
	7/8" Bore	5367-111-008	
2	Rotor		1
	1/2" Bore	5104-751-033	
	5/8" Bore	5104-751-034	
	3/4" Bore	5104-751-035	
	7/8" Bore	5104-751-036	
	1" Bore	5104-751-037	
3	Field		1
	6 Volt	5104-451-032	
	24 Volt	5104-451-033	
	90 Volt	5104-451-034	

Item	Description	Part Number	Qty.
3-1	Terminal Accessory	5103-101-002	1
4	Conduit Box	5200-101-010	1
5	Mounting Accessory	5104-101-002	1

How to Order:

1. Specify Type of Armature Desired.
2. Specify Bore Size for Item 1A-1 or 1B and Item 2.
3. Specify Voltage for Item 3.
4. See Controls Section.

Example:

SFC-400 Clutch Coupling per I-25697 - 90 Volt
 3/4" Armature Hub Bore
 3/4" Rotor Bore

These units, when used in conjunction with the correct Warner Electric conduit box, meet standards set forth in UL508 and are listed under guide card #NMTR2, file #59164.

These units are CSA certified under file #LR11543.

Refer to Service Manual P-200.

Clutch Coupling

SFC-400 Bearing Mounted



For Bore & Keyway sizes see chart below.

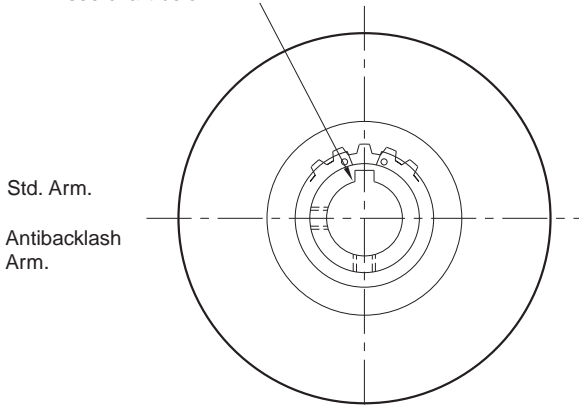

ARMATURE VIEW

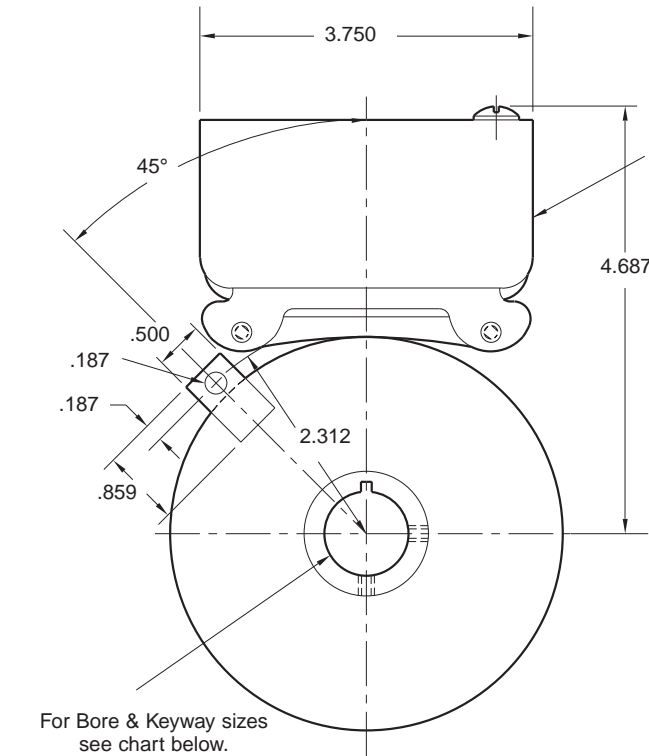

FIELD VIEW

For Bore & Keyway sizes see chart below.

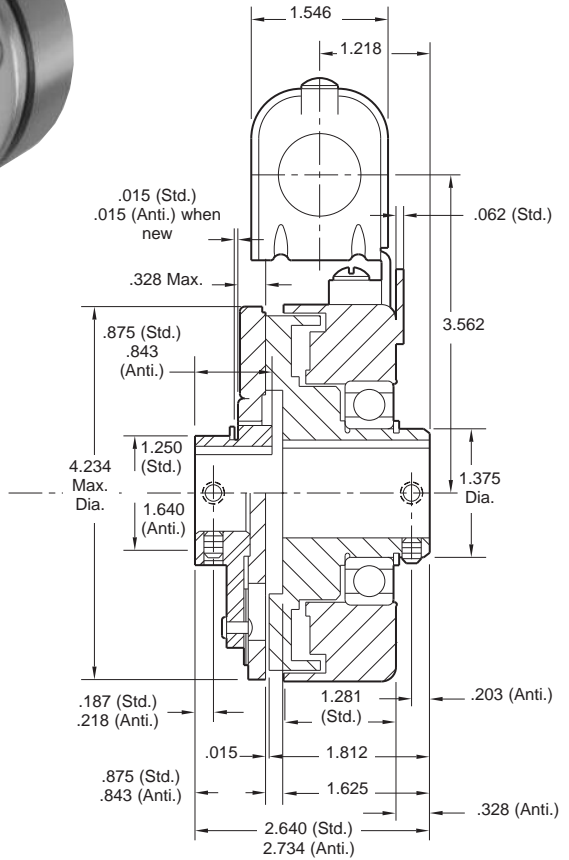

Bore and Keyway Dimensions

Armature Bore Dia.	Keyway	Rotor Bore Dia.	Keyway
.501/.500 *.563/.562	.125 x .062	.501/.500	.125 x .062
.626/.625 *.688/.687	.187 x .093	.626/.625 .751/.750	.187 x .093
.751/.750 .876/.875		.876/.875 1.001/1.000	

* Available on special order only.

Customer Shall Maintain:

1. Armature shaft to be concentric with rotor shaft within .003 T.I.R.

Static Torque	270 lb. in.
Maximum Speed	4,500 rpm
Standard Voltage	D.C. 6, 24, 90

All dimensions are nominal unless otherwise noted.

Information on inertia and weights begins on page 239. Coil data is on pages 250 and 251.



Clutch Coupling

SFC-400 Bearing Mounted

Drawing I-25698

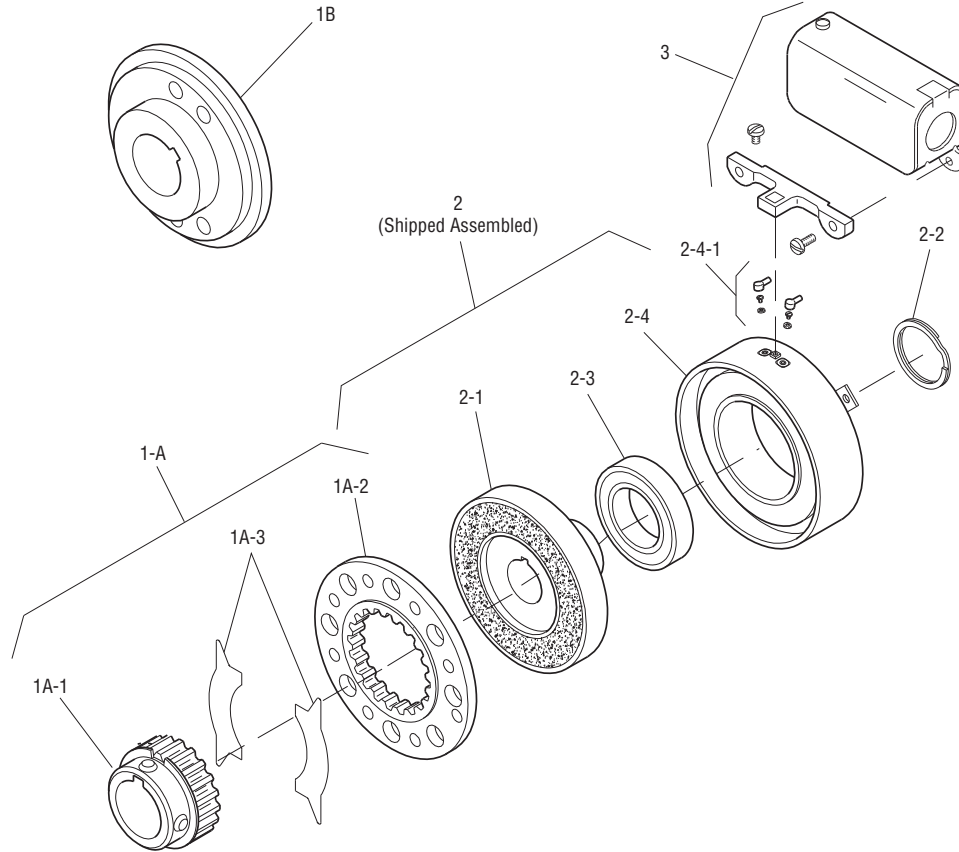

Item	Description	Part Number	Qty.
1A	Armature and Hub		
1A-1	Armature Hub		1
	1/2" Bore	5104-541-002	
	5/8" Bore	5104-541-004	
	3/4" Bore	5104-541-006	
	7/8" Bore	5104-541-007	
1A-2	Armature	5125-111-001	1
1A-3	Release Spring	5104-101-003	1
1B	Antibacklash Armature		1
	1/2" Bore	5367-111-003	
	5/8" Bore	5367-111-005	
	3/4" Bore	5367-111-007	
	7/8" Bore	5367-111-008	
2	Field and Rotor Assembly		1
	6 Volt – 1/2" Bore	5104-452-052	
	24 Volt – 1/2" Bore	5104-452-053	
	90 Volt – 1/2" Bore	5104-452-054	
	6 Volt – 5/8" Bore	5104-452-055	
	24 Volt – 5/8" Bore	5104-452-056	
	90 Volt – 5/8" Bore	5104-452-057	
	6 Volt – 3/4" Bore	5104-452-058	
	24 Volt – 3/4" Bore	5104-452-059	
	90 Volt – 3/4" Bore	5104-452-060	
	6 Volt – 7/8" Bore	5104-452-061	
	24 Volt – 7/8" Bore	5104-452-062	
	90 Volt – 7/8" Bore	5104-452-063	
	6 Volt – 1" Bore	5104-452-064	
	24 Volt – 1" Bore	5104-452-065	
	90 Volt – 1" Bore	5104-452-066	

Item	Description	Part Number	Qty.
2-1	Rotor		1
	1/2" Bore	5104-751-043	
	5/8" Bore	5104-751-044	
	3/4" Bore	5104-751-045	
	7/8" Bore	5104-751-046	
	1" Bore	5104-751-047	
2-2	Retainer Ring	748-0018	1
2-3	Ball Bearing	166-0150	1
2-4	Field		1
	6 Volt	5104-451-038	
	24 Volt	5104-451-039	
	90 Volt	5104-451-040	
2-4-1	Terminal Accessory	5103-101-002	1
3	Conduit Box	5200-101-010	1

How to Order:

1. Specify Type of Armature Desired.
2. Specify Bore Size for Item 1A-1 or 1-B and Item 2.
3. Specify Voltage for Item 2.
4. See Controls Section.

Example:

SFC-400 Clutch Coupling per

I-25698 - 90 Volt
 Antibacklash Armature
 3/4" Armature Hub Bore
 3/4" Rotor Bore

These units meet standards set forth in UL508 and are listed under guide card #NMTR2, file #59164. These units are CSA certified under file #LR11543.

Refer to Service Manual P-200.

Clutch Coupling

SFC-500 Bearing Mounted

Normal Duty



See page 252 for details on Bushings & keyways.

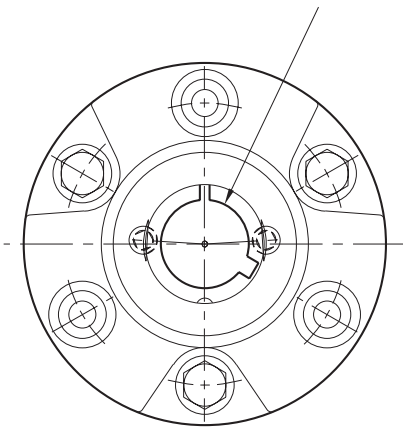

HUB VIEW

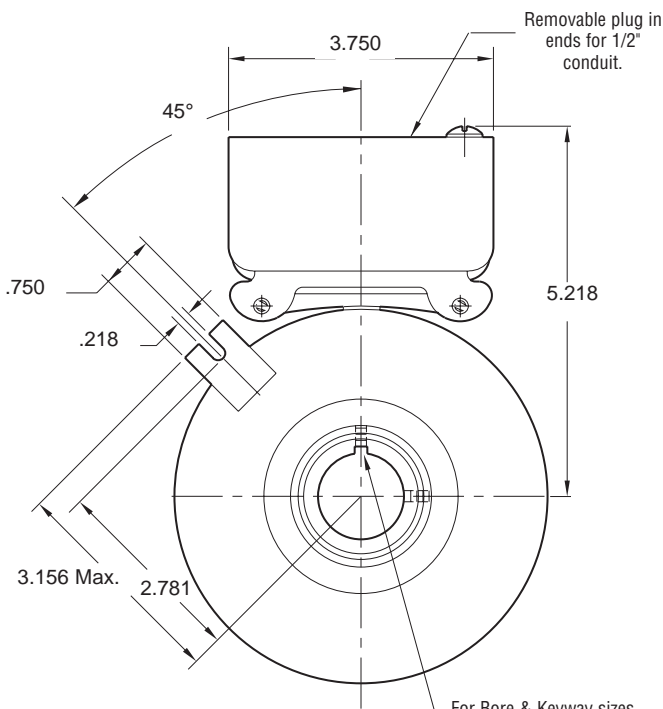

FIELD VIEW

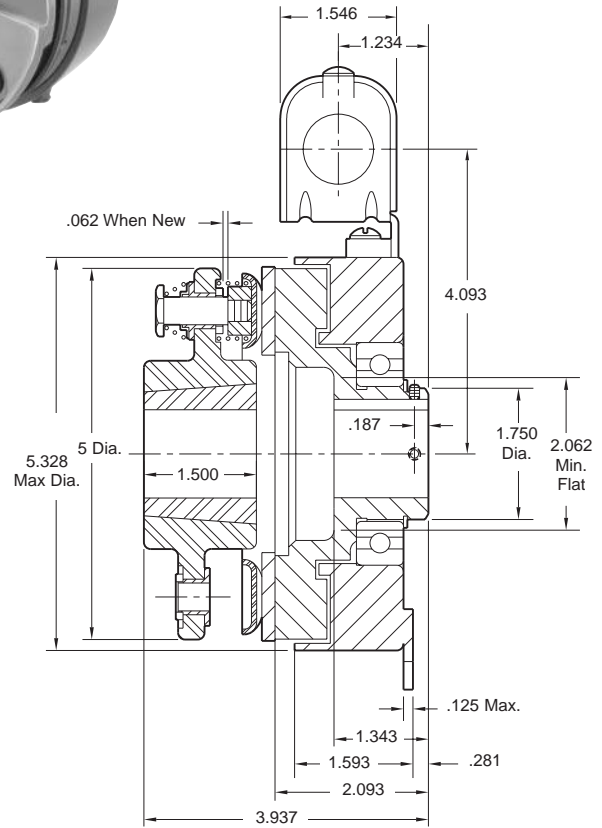

Bore & Keyway Dimensions

Rotor Bore Dia.	Keyway
.751/.750 .876/.875	.187 x .093
.9385/.9375 1.001/1.000 1.126/1.125 1.251/1.250	.250 x .125

Armature Shaft	.500 – 1.250
Rotor Shaft	.750 – 1.250
Static Torque	50 lb.ft.
Maximum Speed	4,000 rpm
Standard Voltage	D.C. 6, 24, 90

All dimensions are nominal unless otherwise noted.

Information on inertia and weights begins on page 239. Coil data is on pages 250 and 251.

Customer Shall Maintain:

1. Armature mounting shaft to be concentric with rotor mounting shaft within .006 T.I.R.



Drawing I-25540

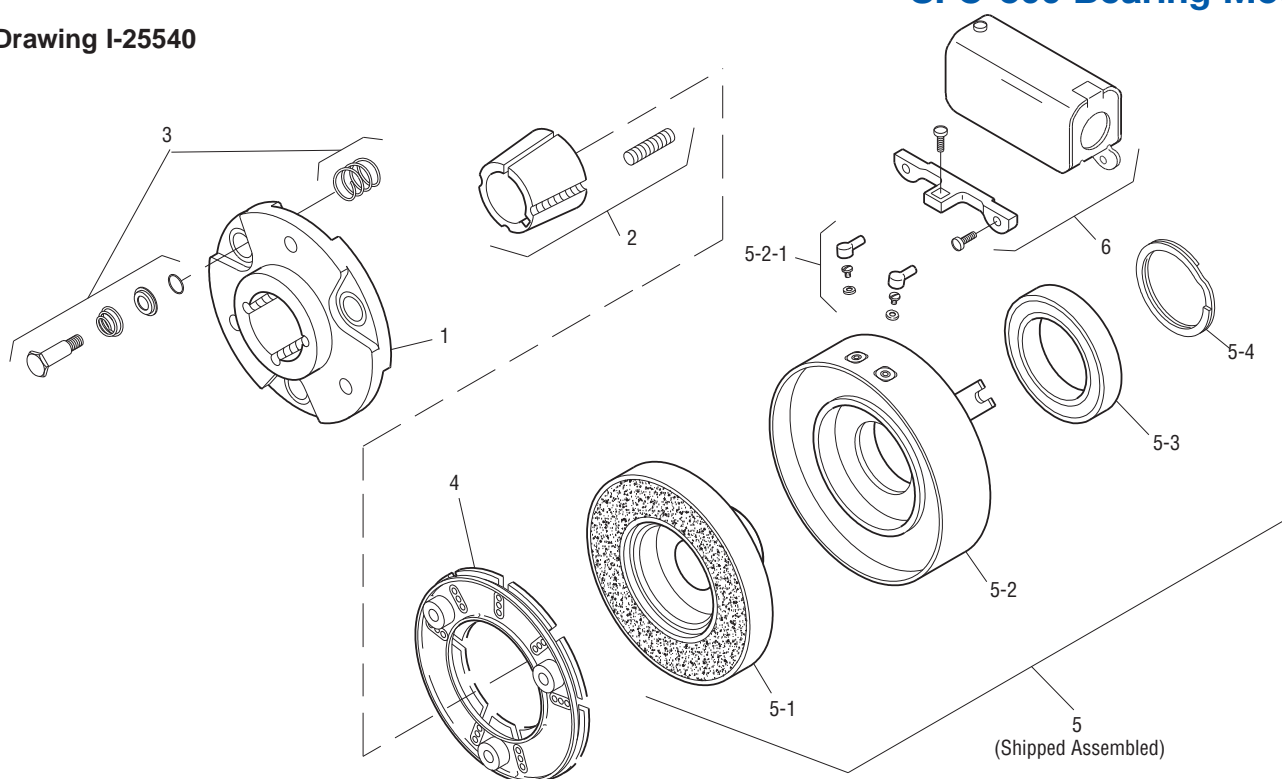

Item	Description	Part Number	Qty.
1	Armature Hub	5300-541-004	1
2	Bushing*		1
	1/2" to 1 1/4" Bore	180-0116 to 180-0128	
3	Autogap Accessory	5200-101-009	3
4	Armature	5300-111-002	1
5	Field and Rotor Assembly		1
	6 Volt – 3/4" Bore	5200-452-002	
	24 Volt – 3/4" Bore	5200-452-004	
	90 Volt – 3/4" Bore	5200-452-005	
	6 Volt – 7/8" Bore	5200-452-008	
	24 Volt – 7/8" Bore	5200-452-010	
	90 Volt – 7/8" Bore	5200-452-011	
	24 Volt – 15/16" Bore	5200-452-016	
	90 Volt – 15/16" Bore	5200-452-017	
	6 Volt – 1" Bore	5200-452-020	
	24 Volt – 1" Bore	5200-452-022	
	90 Volt – 1" Bore	5200-452-023	
	6 Volt – 1-1/8" Bore	5200-452-026	
	24 Volt – 1-1/8" Bore	5200-452-028	
	90 Volt – 1-1/8" Bore	5200-452-029	
	6 Volt – 1-1/4" Bore	5200-452-032	
	24 Volt – 1-1/4" Bore	5200-452-034	
	90 Volt – 1-1/4" Bore	5200-452-035	
5-1	Rotor		1
	3/4" Bore	5200-751-002	
	7/8" Bore	5200-751-003	
	15/16" Bore	5200-751-004	

Item	Description	Part Number	Qty.
	1" Bore	5200-751-005	
	1-1/8" Bore	5200-751-006	
	1-1/4" Bore	5200-751-007	
5-2	Field & Bearing Assembly		1
	6 Volt	5200-451-024	
	24 Volt	5200-451-026	
	90 Volt	5200-451-027	
5-2-1	Terminal Accessory	5311-101-001	1
5-3	Ball Bearing	166-0110	1
5-4	Retainer Ring	748-0002	1
6	Conduit Box	5200-101-010	1

How to Order:

1. Specify Bore Size for Item 2 and Item 5.
2. Specify Voltage for Item 5.
3. See Controls Section.

Example:

SFC-500 Clutch Coupling per I-25540 - 90 Volt
3/4" Bores

These units, when used in conjunction with the correct Warner Electric conduit box, meet the standards set of UL508 and are listed under guide card #NMTR2, file #59164.

These units are CSA certified under file #LR11543

*See page 252 for specific part numbers.

Refer to Service Manual P-202.

Clutch Coupling

Heavy Duty

SFC-500 Bearing Mounted

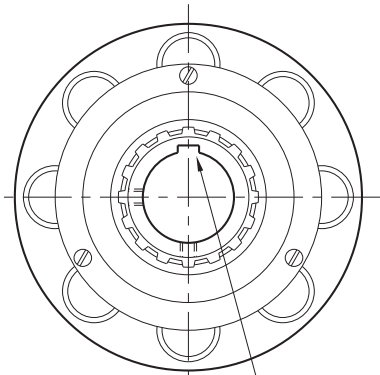

For Bore & Keyway sizes see chart below.

ARMATURE VIEW

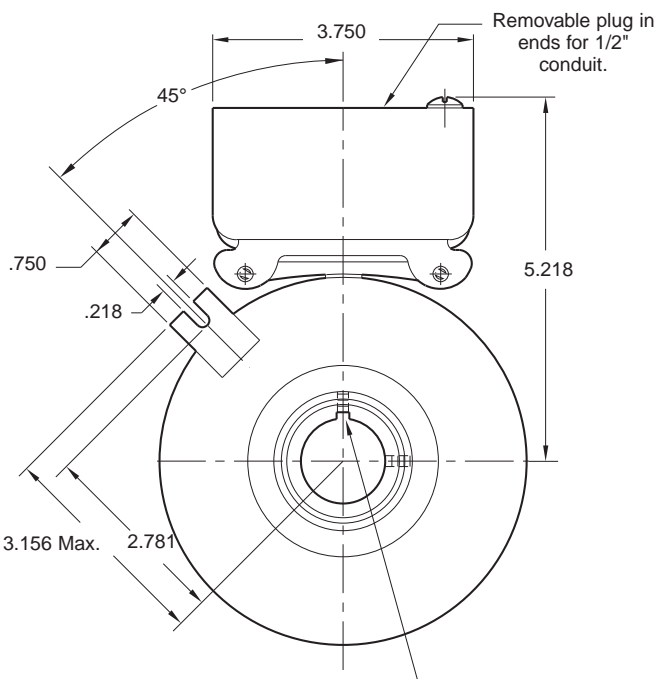

For Bore & Keyway sizes see chart below.

FIELD VIEW

Customer Shall Maintain:

1. Angular alignment of shafts within 1/2 degree.
2. Armature mounting shaft to be concentric with rotor mounting shaft within .006 T.I.R.

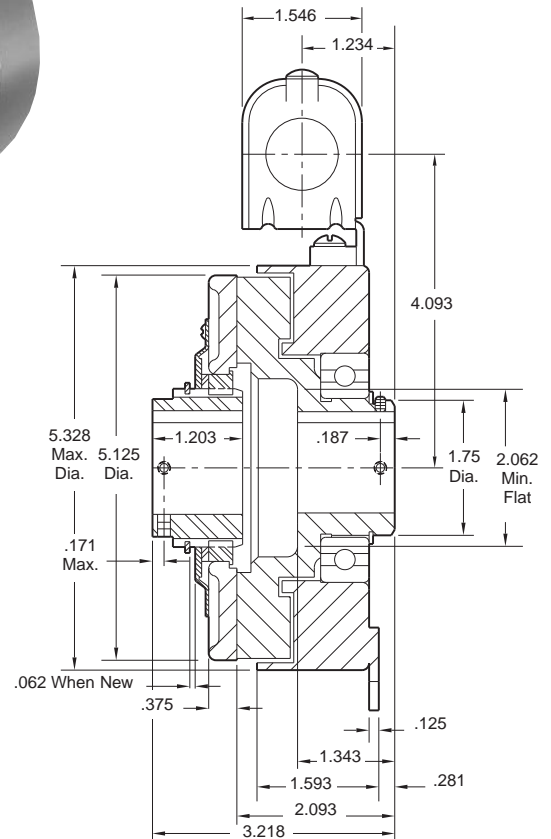

Bore & Keyway Dimensions

Bore Dia.	Keyway
.751/.750	.187 x .093
.876/.875	
.9385/.9375	
1.001/1.000	.250 x .125
1.126/1.125	
1.251/1.250	

Armature Shaft .750 – 1.250

Rotor Shaft .750 – 1.250

Static Torque 50 lb.ft.

Maximum Speed 4,000 rpm

Standard Voltage D.C. 6, 24, 90

All dimensions are nominal unless otherwise noted.

Information on inertia and weights begins on page 239. Coil data is on pages 250 and 251.

SFC-500 Bearing Mounted

Drawing I-25541

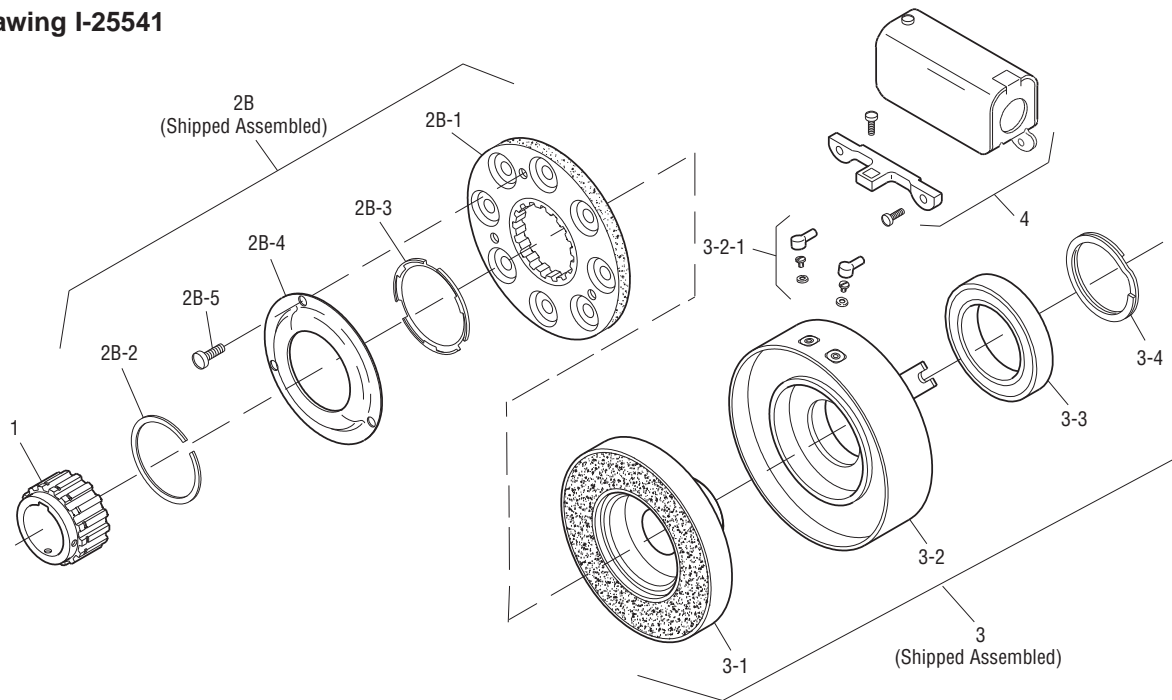

Item	Description	Part Number	Qty.
1	Armature Hub Assembly		1
	3/4" Bore	5200-541-002	
	7/8" Bore	5200-541-003	
	15/16" Bore	5200-541-004	
	1" Bore	5200-541-005	
	1-1/8" Bore	5200-541-006	
	1-1/4" Bore	5200-541-007	
2B	Armature Assembly w/Autogap	5230-111-002	1
2B-1	Armature	5230-111-001	1
2B-2	Retainer Ring	748-0355	1
2B-3	Autogap Spring	808-0412	1
2B-4	Retainer Plate	748-0364	1
2B-5	Screw	797-0028	3
3	Field and Rotor Assembly		1
	6 Volt – 3/4" Bore	5200-452-002	
	24 Volt – 3/4" Bore	5200-452-004	
	90 Volt – 3/4" Bore	5200-452-005	
	6 Volt – 7/8" Bore	5200-452-008	
	24 Volt – 7/8" Bore	5200-452-010	
	90 Volt – 7/8" Bore	5200-452-011	
	24 Volt – 15/16" Bore	5200-452-016	
	90 Volt – 15/16" Bore	5200-452-017	
	6 Volt – 1" Bore	5200-452-020	
	24 Volt – 1" Bore	5200-452-022	
	90 Volt – 1" Bore	5200-452-023	
	6 Volt – 1-1/8" Bore	5200-452-026	
	24 Volt – 1-1/8" Bore	5200-452-028	
	90 Volt – 1-1/8" Bore	5200-452-029	
	6 Volt – 1-1/4" Bore	5200-452-032	
	24 Volt – 1-1/4" Bore	5200-452-034	
	90 Volt – 1-1/4" Bore	5200-452-035	

Item	Description	Part Number	Qty.
3-1	Rotor		1
	3/4" Bore	5200-751-002	
	7/8" Bore	5200-751-003	
	15/16" Bore	5200-751-004	
	1" Bore	5200-751-005	
	1-1/8" Bore	5200-751-006	
	1-1/4" Bore	5200-751-007	
3-2	Field & Bearing Assembly		1
	6 Volt	5200-451-024	
	24 Volt	5200-451-026	
	90 Volt	5200-451-027	
3-2-1	Terminal Accessory	5311-101-001	1
3-3	Ball Bearing	166-0110	1
3-4	Retainer Ring	748-0002	1
4	Conduit Box	5200-101-010	1

How to Order:

1. Specify Bore Size for Item 1 and Item 3.
2. Specify Voltage for Item 3.
3. See Controls Section.

Example:

SFC-500 Clutch Coupling per I-25541- 90 Volt
3/4" Armature Hub Bore
7/8" Rotor Bore

These units, when used in conjunction with the correct Warner Electric conduit box, meet standards set forth in UL508 and are listed under guide card #NMTR2, file #59164.

These units are CSA certified under file #LR11543

Refer to Service Manual P-202.

Clutch Coupling

SFC-650 Flange Mounted

See page 252 for details on Bushings.

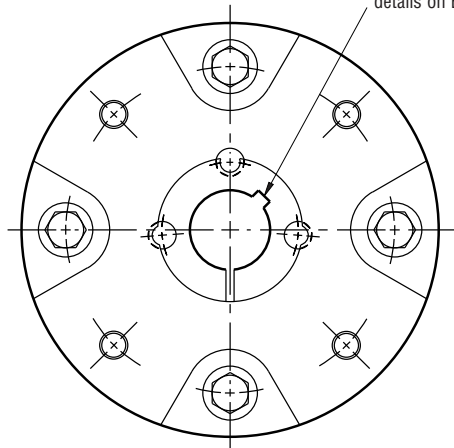

HUB VIEW

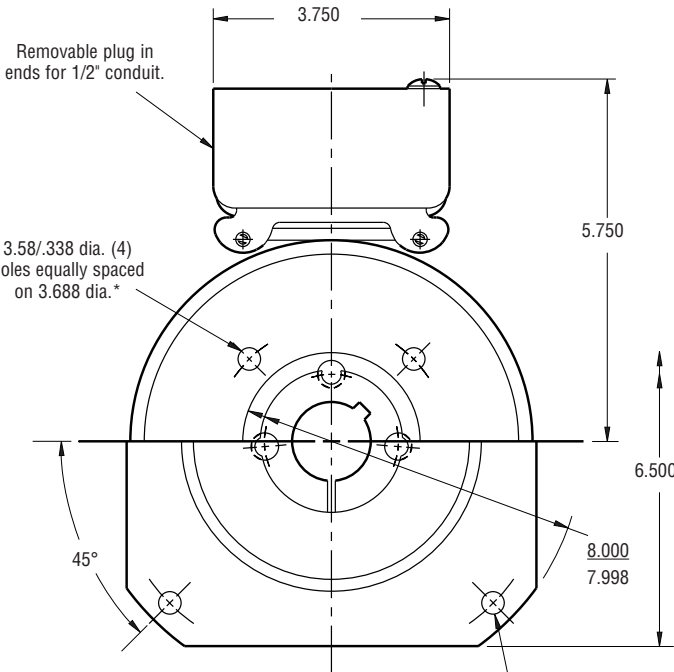

FIELD VIEW

(Inside & Outside Mounted)

3.58/.338 dia. (4) holes equally spaced on 7.250 dia.*

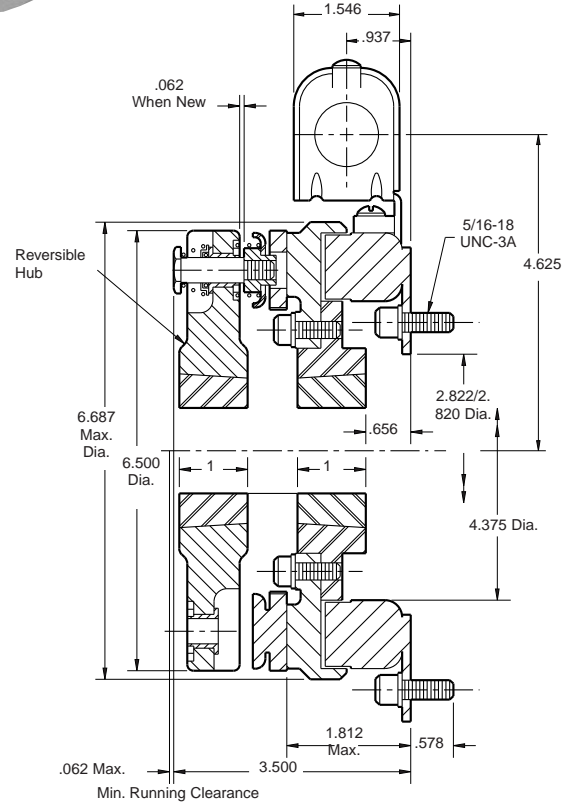

* Mounting holes are within .010 of true position relative to pilot diameter.

Customer Shall Maintain:

1. Concentricity of field mounting pilot diameter with rotor mounting shaft within .006 T.I.R.
2. Squareness of field mounting face with shaft within .006 T.I.R. measured at field mounting bolt circle.
3. Rotor mounting pilot diameter must be concentric with shaft within .006 T.I.R.
4. Armature mounting shaft to be concentric with rotor mounting shaft within .006 T.I.R.

Armature Shaft	.500 – 1.625
Rotor Shaft	.500 – 1.625
Static Torque	95 lb.ft.
Maximum Speed	3,600 rpm
Standard Voltage	D.C. 6, 24, 90

All dimensions are nominal unless otherwise noted.

Information on inertia and weights begins on page 239. Coil data is on pages 250 and 251.



Clutch Coupling

SFC-650 Flange Mounted

Drawing I-25728

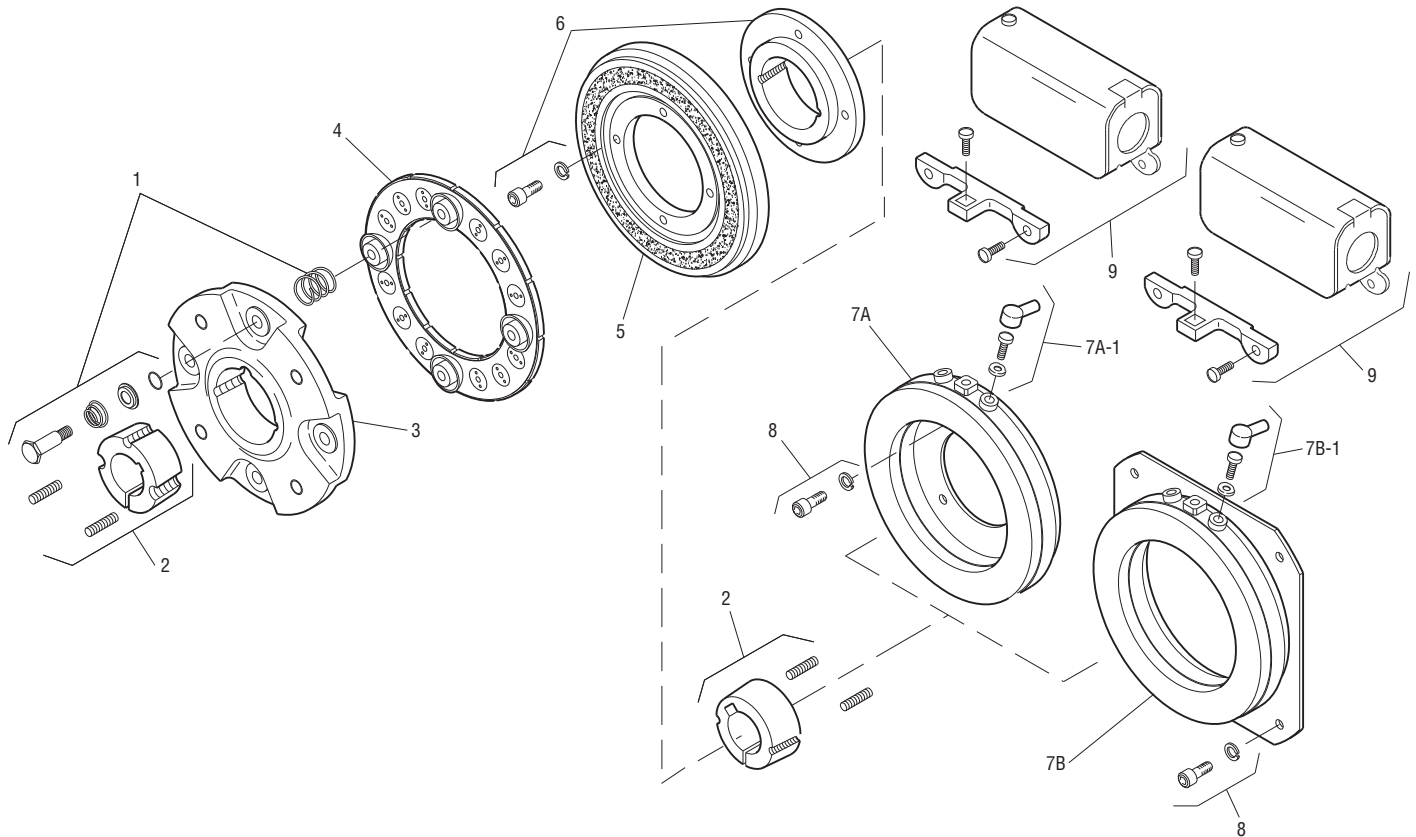

Item	Description	Part Number	Qty.
1	Autogap Accessory	5181-101-010	4
2	Bushing*		2
	1/2" to 1-5/8" Bore	180-0326 to 180-0344	1
3	Armature Hub	5207-541-002	1
4	Armature	5281-111-002	1
5	Rotor	5281-751-001	1
6	Rotor Hub &		
	Mounting Accessory	5207-101-005	1
7A	Field - Inside Mounted		1
	6 Volt	5207-451-009	
	24 Volt	5207-451-012	
	90 Volt	5207-451-011	
7A-1	Terminal Accessory	5311-101-001	1
7B	Field - Outside Mounted		1
	6 Volt	5207-451-003	
	24 Volt	5207-451-006	
	90 Volt	5207-451-005	
7B-1	Terminal Accessory	5311-101-001	1

Item	Description	Part Number	Qty.
8	Mounting Accessory	5321-101-002	1
9	Conduit Box	5200-101-010	1

How to Order:

1. Specify Bore Size for Item 2 (both shafts).
2. Specify Voltage for Item 7.
3. Specify Inside or Outside Mounted for Item 7.
4. See Controls Section.

Example:

SFC-650 Clutch Coupling
Flange Mounted per I-25728 - 90 Volt
1" Bore

These units, when used in conjunction with the correct Warner Electric conduit box, meet the standards of UL508 and are listed under guide card #NMTR, file #59164.

These units are CSA certified under file #LR11543.

*See page 252 for specific part numbers.

Refer to Service Manual P-202.

Clutch Coupling

SFC-650 Bearing Mounted



See page 252 for details on Bushings.

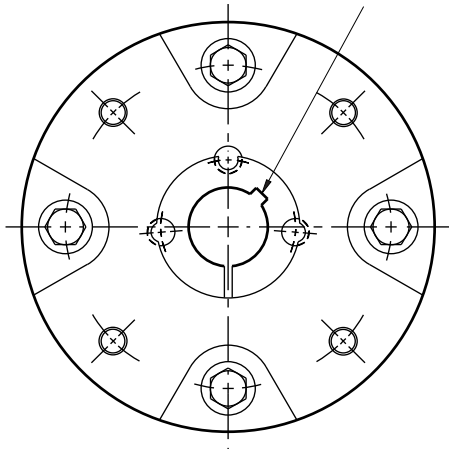

HUB VIEW

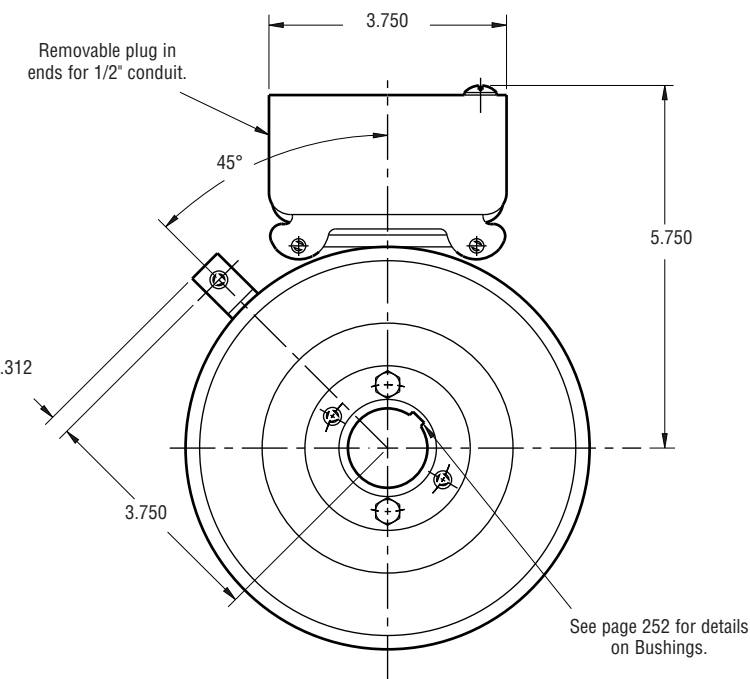

FIELD VIEW

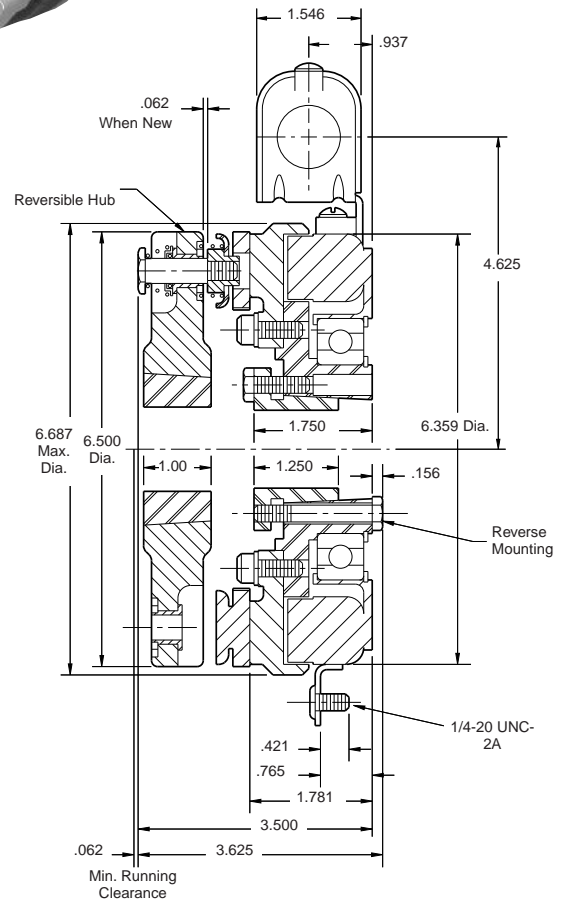

Armature Shaft	.500 – 1.625
----------------	--------------

Rotor Shaft	.500 – 1.500
-------------	--------------

Static Torque	95 lb.ft.
---------------	-----------

Maximum Speed	3,600 rpm
---------------	-----------

Standard Voltage	D.C. 6, 24, 90
------------------	----------------

Customer Shall Maintain:

1. Armature mounting shaft to be concentric with rotor mounting shaft within .006 T.I.R.

All dimensions are nominal unless otherwise noted.

Information on inertia and weights begins on page 239. Coil data is on pages 250 and 251.



Clutch Coupling

SFC-650 Bearing Mounted

Drawing I-25729

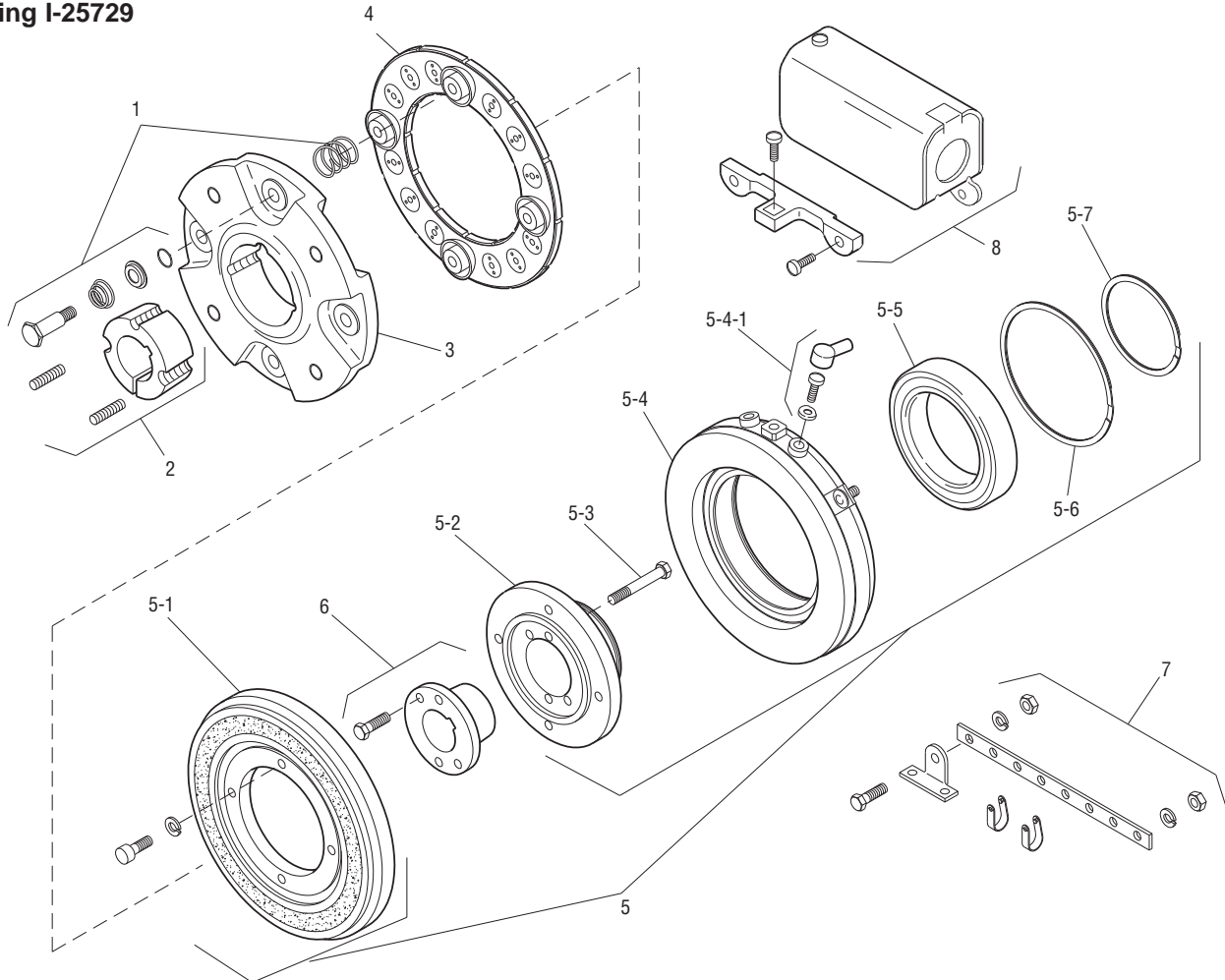

Item	Description	Part Number	Qty.
1	Autogap Accessory	5181-101-010	4
2	Bushing*		1
	1/2" to 1-5/8" Bore	180-0326 to 180-0344	
3	Armature Hub	5207-541-002	1
4	Armature	5281-111-002	1
5	Field and Rotor Assembly		1
	6 Volt	5207-452-002	
	24 Volt	5207-452-005	
	90 Volt	5207-452-004	
5-1	Rotor Assembly	5281-751-001	1
5-2	Rotor Hub	540-0614	1
5-3	Reverse Mounting Accessory	5201-101-005	1
5-4	Field Assembly		1
	6 Volt	5281-451-002	
	24 Volt	5281-451-004	
	90 Volt	5281-451-005	
5-4-1	Terminal Accessory	5311-101-001	1
5-5	Ball Bearing	166-0104	1
5-6	Retainer Ring - Exterior	748-0004	1

Item	Description	Part Number	Qty.
5-7	Retainer Ring - Interior	748-0104	1
6	Bushing*		1
	1/2" to 1-1/2" Bore	180-0002 to 180-0018	
†7	Torque Arm Accessory	5207-101-003	1
8	Conduit Box	5200-101-010	1

How to Order:

1. Specify Bore Size of Item 2 and Item 6.
2. Specify Voltage for Item 5.
3. See Controls Section.

Example:

SFC-650 Clutch Coupling,
Bearing Mounted per I-25729 - 90 Volt, 1" Bore

These units, when used in conjunction with the correct Warner Electric conduit box, meet the standards of UL508 and are listed under guide card #NMTR, file #59164.

These units are CSA certified under file #LR11543

*See page 252 for specific part numbers.

Refer to Service Manual P-202.

†Optional – not included in price.

Clutch Coupling

SFC-825 Flange Mounted



See page 252 for details on Bushings.

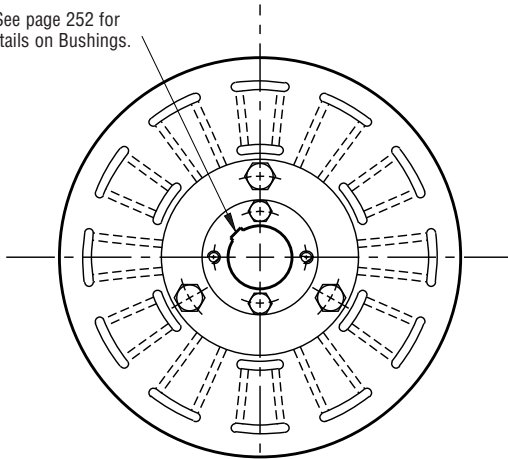

ARMATURE VIEW

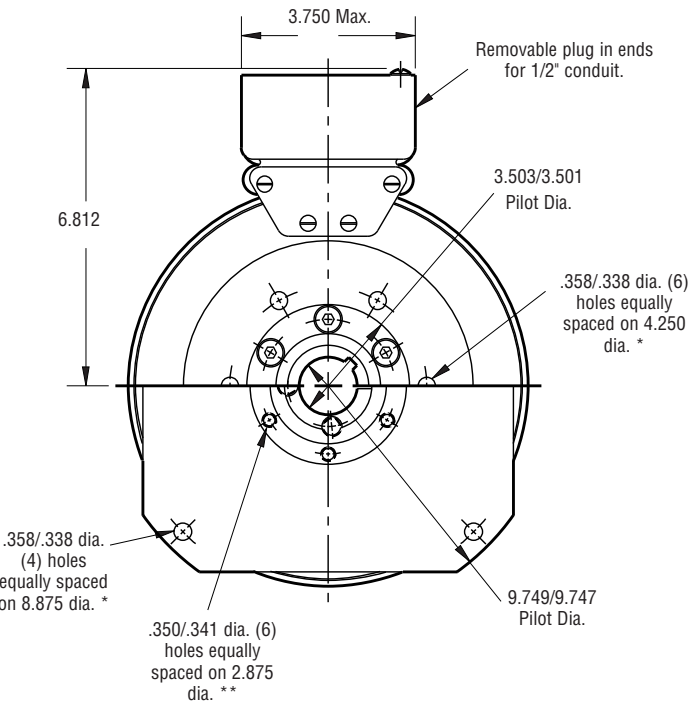

FIELD VIEW

(Inside & Outside Mounted)

Customer Shall Maintain:

1. Concentricity of field mounting pilot diameter with rotor mounting shaft within .006 T.I.R.
2. Squareness of field mounting face with rotor shaft within .006 T.I.R. measured at field mounting bolt circle.
3. Rotor mounting shaft concentric with armature mounting shaft within .006 T.I.R.
4. Angular alignment of shafts within 1/2 degree.

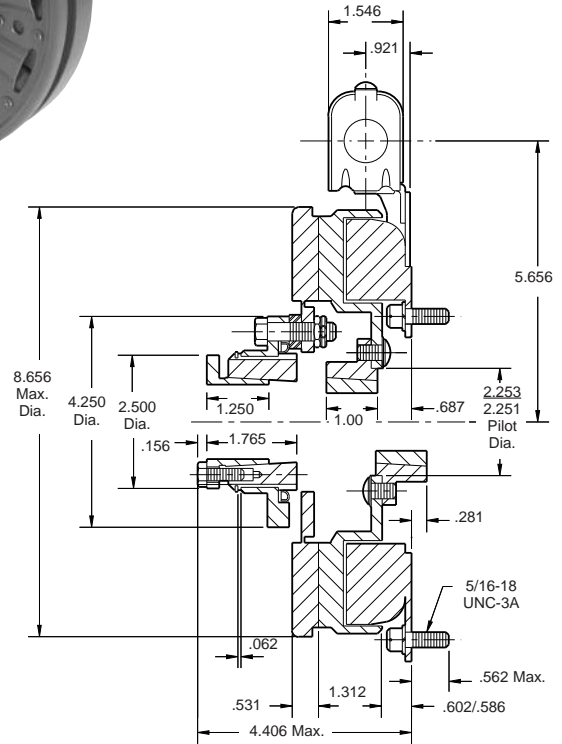

* Mounting holes are within .010 of true position relative to pilot diameter.

** Mounting holes are within .008 of true position relative to pilot diameter.

Armature Shaft	.500 – 1.500
Rotor Shaft	.500 – 1.250
Static Torque	125 lb. ft.
Maximum Speed	4,000 rpm
Standard Voltage	D.C. 6, 24, 90

All dimensions are nominal unless otherwise noted.

Information on inertia and weights begins on page 239. Coil data is on pages 250 and 251.

Note: The two mating shafts on which the clutch is mounted must be mounted rigidly to prevent flexing during engagement. Any flexing will cause vibration and rapid clutchwear. The drive motor should not be mounted on the reducer "scoop" mount or other flexible mounts.

Drawing I-25564

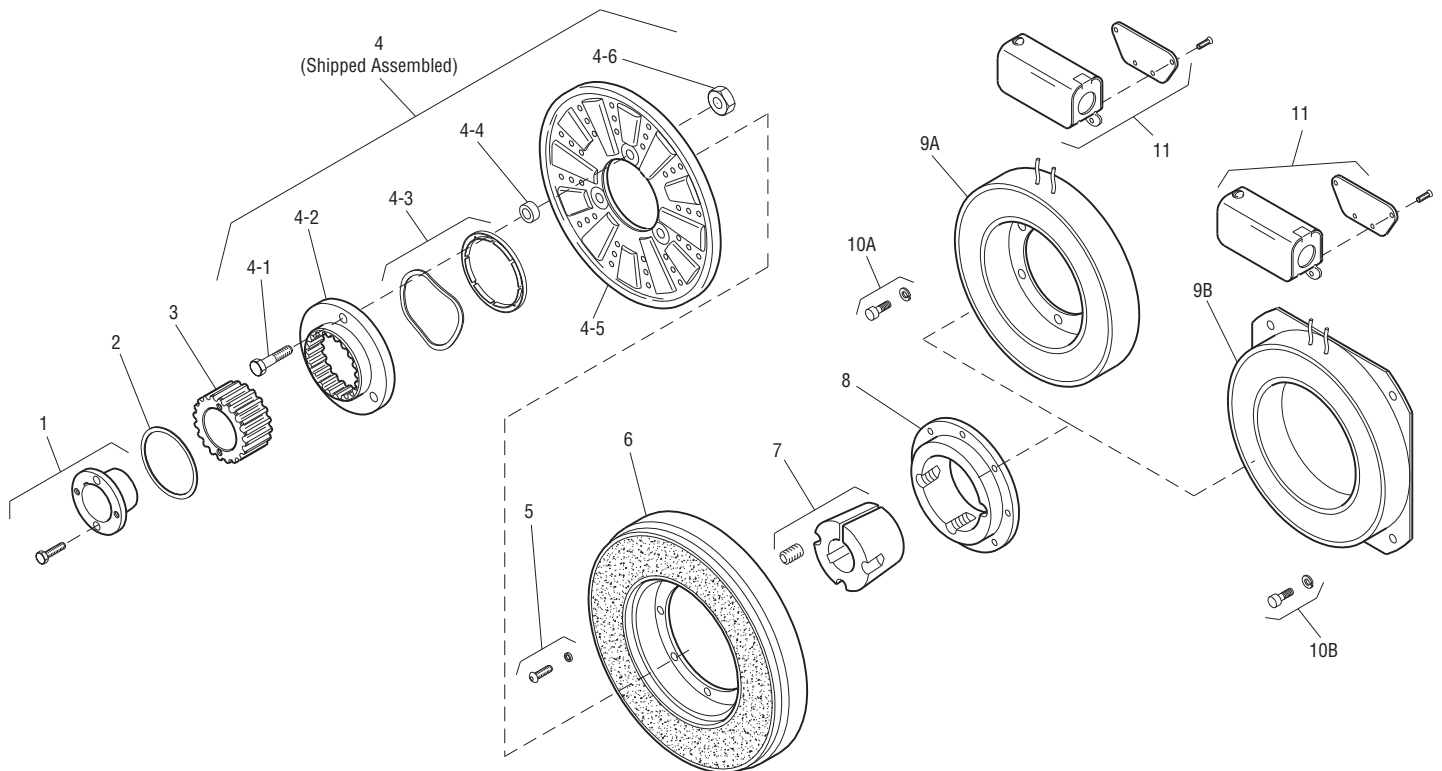

Item	Description	Part Number	Qty.
1	Bushing*		1
	1/2" to 1-1/2" Bore	180-0002 to 180-0018	
2	Retainer Ring	748-0006	1
3	Splined Hub	540-0057	1
4	Armature & Splined Adapter	5201-111-001	1
4-1	Capscrew	797-0341	3
4-2	Splined Adapter	104-0008	1
4-3	Autogap Accessory	5321-101-006	1
4-4	Spacer	748-0333	3
4-5	Armature	5321-111-022	1
4-6	Locknut	661-0004	3
5	Mounting Accessory	5201-101-007	1
6	Rotor		1
	Standard Friction Material	5201-751-003	
	†Optional LK Facing	5201-751-007	
7	Bushing*		1
	1/2" to 1-1/4" Bore	180-0101 to 180-0013	
8	Rotor Hub	540-0013	1
9A	Field - Inside Mounted		1
	6 Volt	5201-451-006	
	24 Volt	5201-451-008	
	90 Volt	5201-451-010	

Item	Description	Part Number	Qty.
9B	Field - Outside Mounted		1
	6 Volt	5201-451-014	
	24 Volt	5201-451-016	
	90 Volt	5201-451-018	
10A	Mounting Accessory - I.M.	5321-101-001	1
10B	Mounting Accessory - O.M.	5321-101-002	1
11	Conduit Box	5200-101-012	1

How to Order:

1. Specify Bore Size for Item 1.
2. Specify Bore Size for Item 7.
3. Specify Voltage for Item 9A or 9B.
4. Specify Inside Mounted for Items 9A and 10A or Outside Mounted for Items 9B and 10B.
5. See Controls Section.

Example:

SFC-825 Clutch Coupling per I-25564 - 90 Volt, Inside Mounted, 1" Bore (Item 1), 1" Bore (Item 7)

These units, when used in conjunction with the correct Warner Electric conduit box, meet standards of UL508 and are listed under guide card #NMTR, file #59164. These units are CSA certified under file #LR11543.

*See page 252 for specific part numbers.

Refer to Service Manual P-207.

†Optional LK facing available. For more information, see page 232.

Clutch Coupling

SFC-825 Bearing Mounted



See page 252 for details on Bushings.

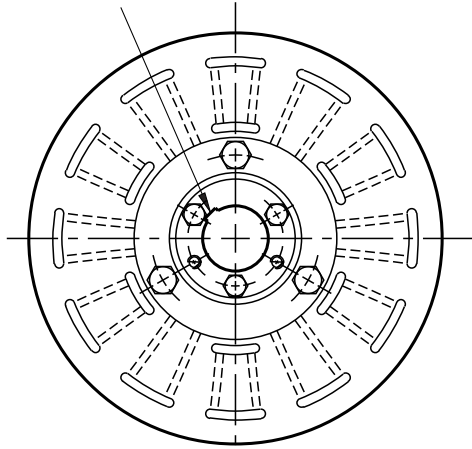

ARMATURE VIEW

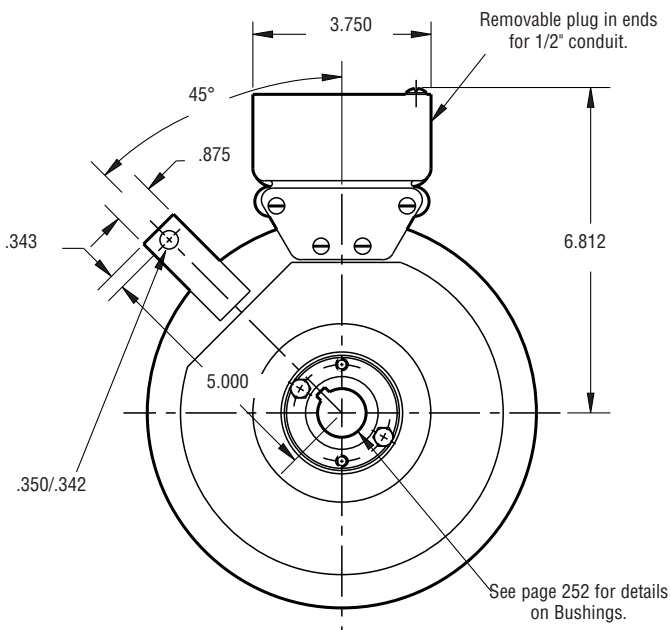

FIELD VIEW

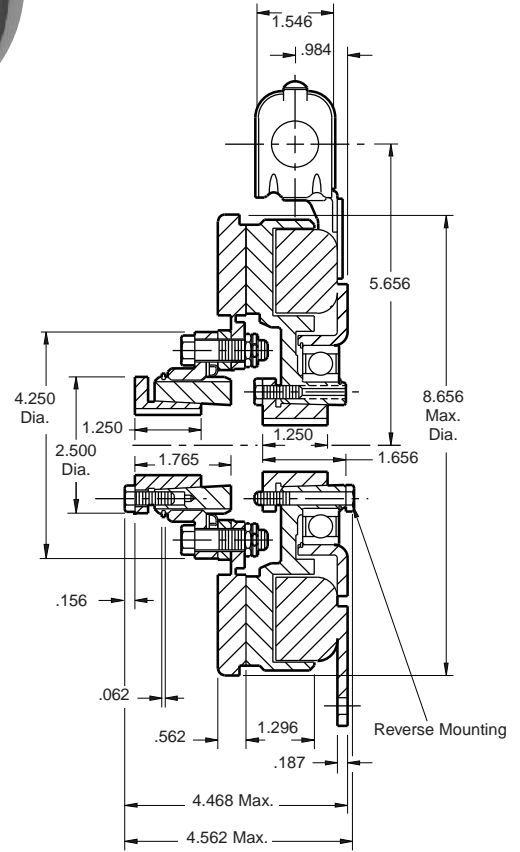

Armature Shaft	.500 – 1.500
Rotor Shaft	.500 – 1.500
Static Torque	150 lb. ft.
Maximum Speed	3,600 rpm
Standard Voltage	D.C. 6, 24, 90

All dimensions are nominal unless otherwise noted.

Information on inertia and weights begins on page 239. Coil data is on pages 250 and 251.

Customer Shall Maintain:

1. Armature mounting shaft concentric with field and rotor mounting shaft within .006 T.I.R.
2. Angular alignment of shafts within 1/2 degree.



Drawing I-25574

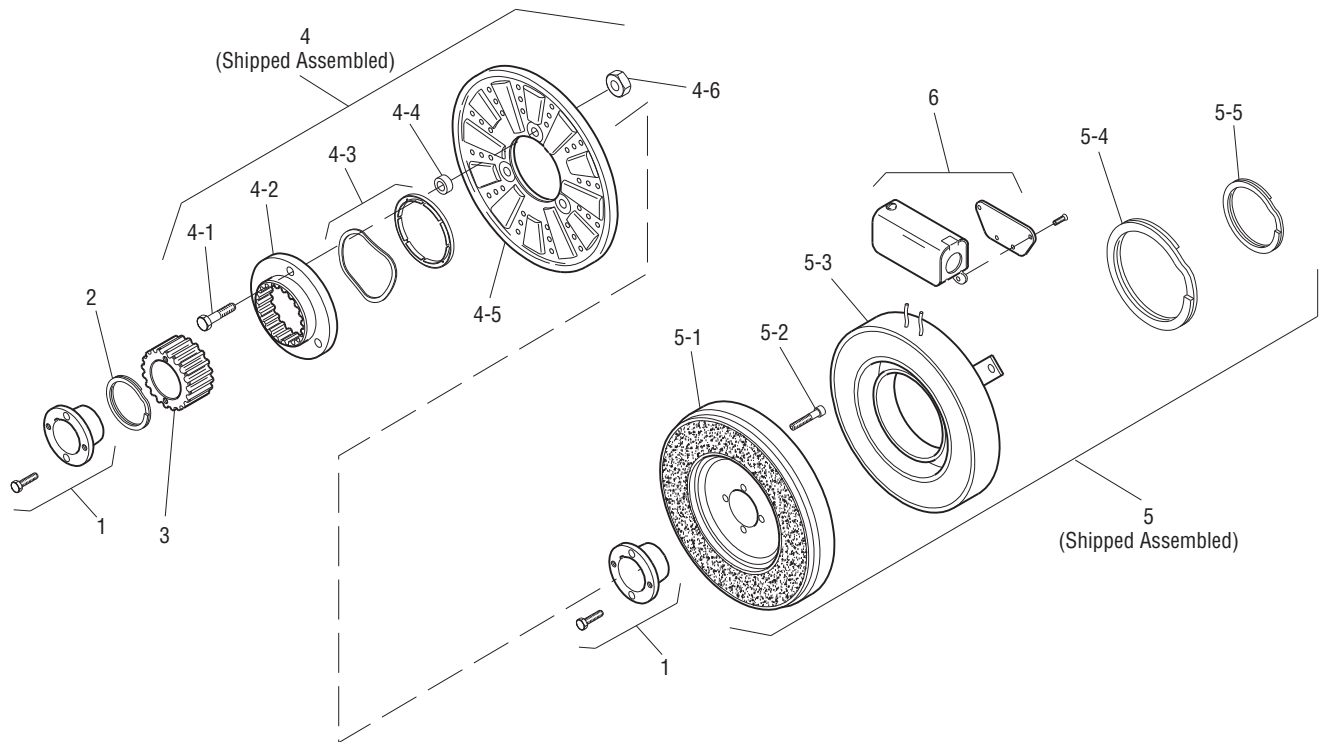

Item	Description	Part Number	Qty.
1	Bushing*		2
	1/2" to 1-1/2" Bore	180-0002 to 180-0018	
2	Retainer Ring	748-0006	1
3	Splined Hub	540-0057	1
4	Armature & Splined Adapter	5201-111-001	1
4-1	Capscrew	797-0341	3
4-2	Splined Adapter	104-0008	1
4-3	Autogap Accessory	5321-101-006	1
4-4	Spacer	748-0333	3
4-5	Armature	5321-111-022	1
4-6	Locknut	661-0004	3
5	Field & Rotor Assembly		1
	6 Volt	5201-452-002	
	24 Volt	5201-452-004	
	90 Volt	5201-452-006	
5-1	Rotor		1
	Standard Friction Material	5201-751-008	
5-2	Mounting Accessory	5201-101-005	1
5-3	Field		1
	6 Volt	5201-451-054	
	24 Volt	5201-451-056	
	90 Volt	5201-451-057	

Item	Description	Part Number	Qty.
5-4	Retainer Ring	748-0111	1
5-5	Retainer Ring	748-0016	1
6	Conduit Box	5200-101-012	1

How to Order:

1. Specify Bore Size for Item 1 (both shafts).
2. Specify Voltage for Item 5.
3. See Controls Section.

Example:

SFC-825 Clutch Coupling per I-25574 - 90 Volt, 1" Bore

These units, when used in conjunction with the correct Warner Electric conduit box, meet the standards of UL508 and are listed under guide card #NMTR, file #59164.

These units are CSA certified under file #LR11543.

*See page 252 for specific part numbers.

Refer to Service Manual P-207.

Clutch Coupling

SFC-1000 Flange Mounted



See page 252 for details on Bushings.

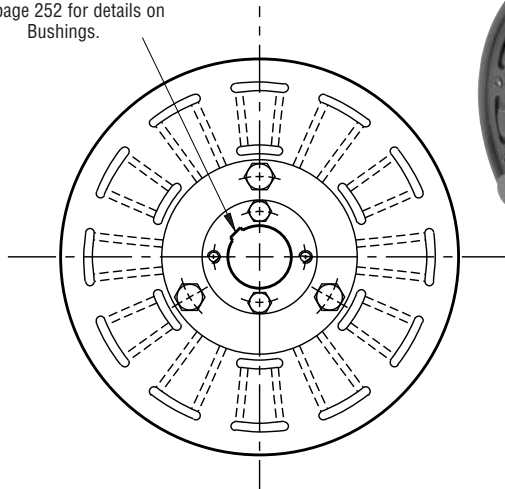

ARMATURE VIEW

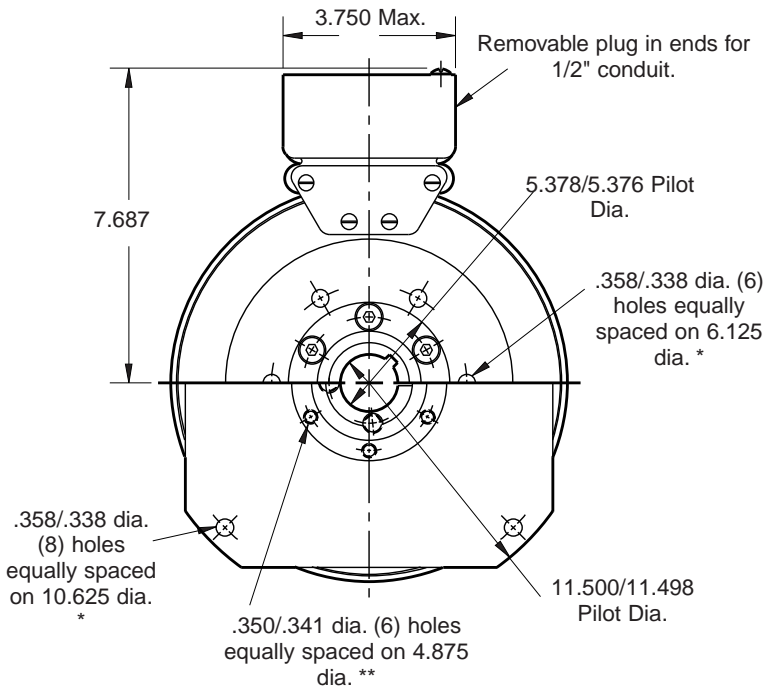

FIELD VIEW

(Inside & Outside Mounted)

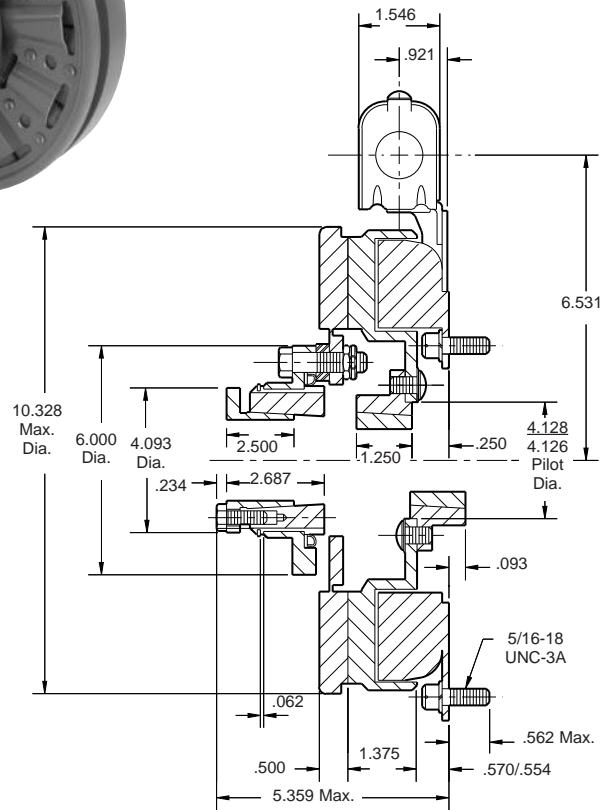

* Mounting holes are within .010 of true position relative to pilot diameter.

** Mounting holes are within .008 of true position relative to pilot diameter.

Armature Shaft	.750 – 2.687
Rotor Shaft	.500 – 2.000
Static Torque	240 lb. ft.
Maximum Speed	3,600 rpm
Standard Voltage	D.C. 6, 24, 90

All dimensions are nominal unless otherwise noted.

Information on inertia and weights begins on page 239. Coil data is on pages 250 and 251.

Note: The two mating shafts on which the clutch is mounted must be mounted rigidly to prevent flexing during engagement. Any flexing will cause vibration and rapid clutchwear. The drive motor should not be mounted on the reducer "scoop" mount or other flexible mounts.

Customer Shall Maintain:

1. Concentricity of field mounting pilot diameter with rotor mounting shaft within .006 T.I.R.
2. Squareness of field mounting face with rotor shaft within .006 T.I.R. measured at field mounting bolt circle.
3. Rotor mounting shaft concentric with armature mounting shaft within .006 T.I.R.
4. Angular alignment of shafts within 1/2 degree.



Clutch Coupling

SFC-1000 Flange Mounted

Drawing I-25584

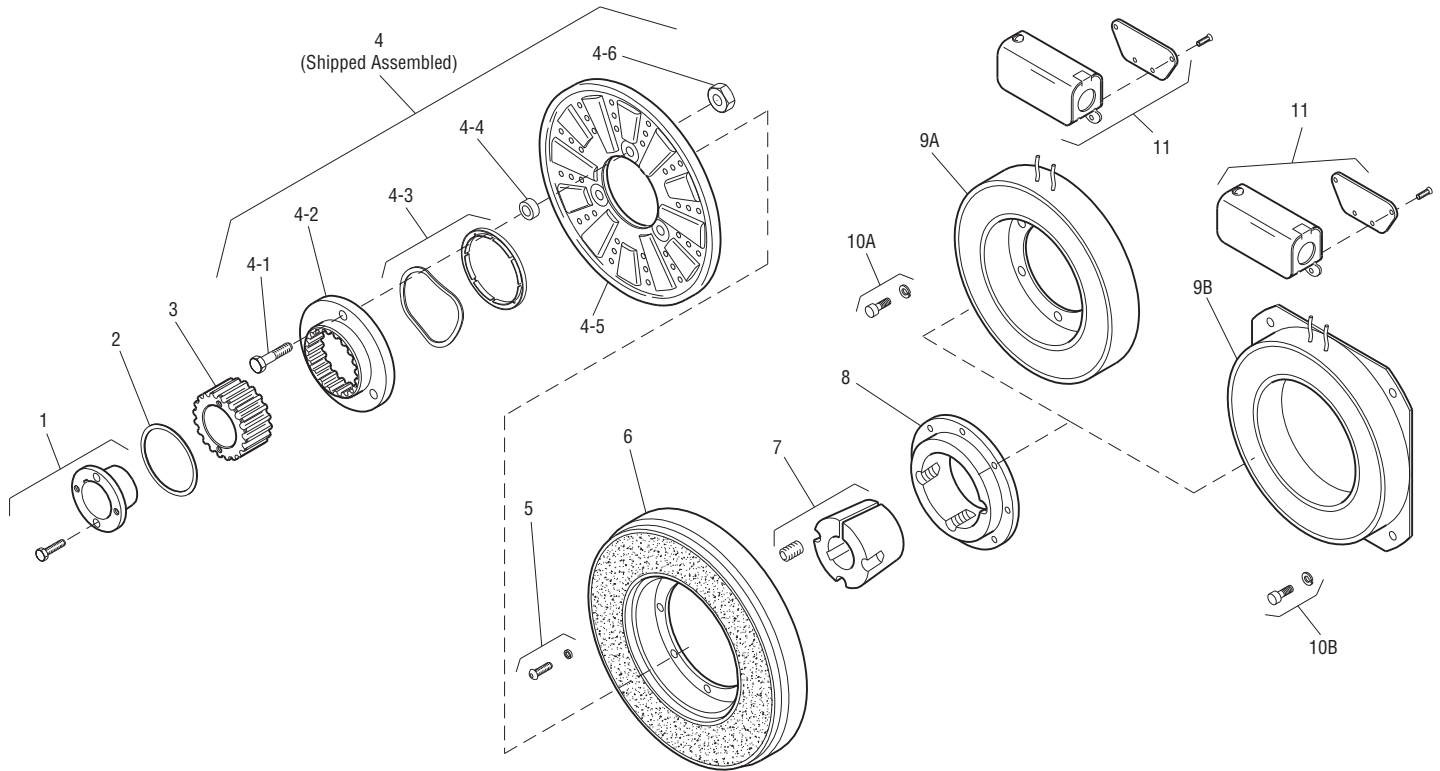

Item	Description	Part Number	Qty.
1	Bushing*		1
	3/4" to 2-11/16" Bore	180-0026 to 180-0057	
2	Retainer Ring	748-0007	1
3	Splined Hub	540-0062	1
4	Armature & Splined Adapter	5202-111-001	1
4-1	Capscrew	797-0341	3
4-2	Splined Adapter	104-0009	1
4-3	Autogap Accessory	5322-101-004	1
4-4	Spacer	748-0333	3
4-5	Armature	5322-111-036	1
4-6	Locknut	661-0004	3
5	Mounting Accessory	5201-101-007	1
6	Rotor		1
	Standard Friction Material	5202-751-003	
	†Optional LK Facing	5202-751-007	
7	Bushing*		1
	1/2" to 2" Bore	180-0155 to 180-0179	
8	Rotor Hub	540-0315	1
9A	Field - Inside Mounted		1
	6 Volt	5202-451-004	
	24 Volt	5202-451-006	
	90 Volt	5202-451-007	

Item	Description	Part Number	Qty.
9B	Field - Outside Mounted		1
	6 Volt	5202-451-011	
	24 Volt	5202-451-013	
	90 Volt	5202-451-014	
10A	Mounting Accessory - I.M.	5321-101-001	1
10B	Mounting Accessory - O.M.	5321-101-002	2
11	Conduit Box	5200-101-012	1

How to Order:

1. Specify Bore Size for Item 1.
2. Specify Bore Size for Item 7.
3. Specify Voltage for Item 9A or 9B.
4. Specify Inside Mounted for Items 9A and 10A or Outside Mounted for Items 9B and 10B.
5. See Controls Section.

Example:

SFC-1000 Clutch Coupling per I-25584 - 90 Volt, Inside Mounted, 1-1/4" Bore (Item 1), 1-1/2" Bore (Item 7)

These units, when used in conjunction with the correct Warner Electric conduit box, meet standards of UL508 and are listed under guide card #NMTR, file #59164. These units are CSA certified under file #LR11543.

*See page 252 for specific part numbers.

Refer to Service Manual P-207.

†Optional LK facing available. For more information, see page 232.

Clutch Coupling

SFC-1000 Bearing Mounted



See page 252 for details on Bushings.

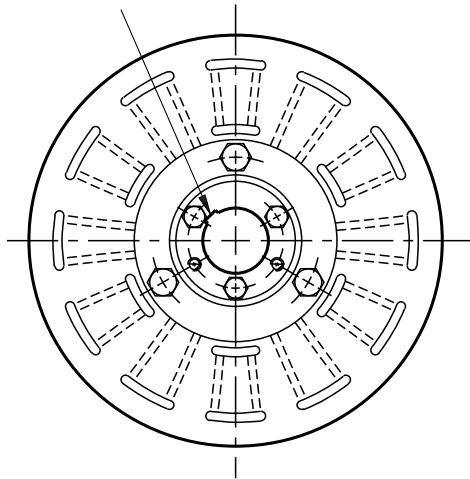

ARMATURE VIEW

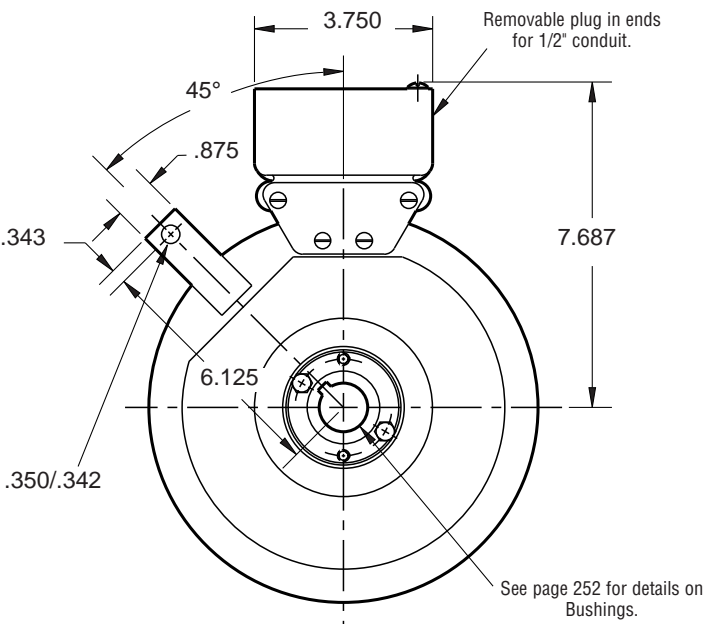

FIELD VIEW

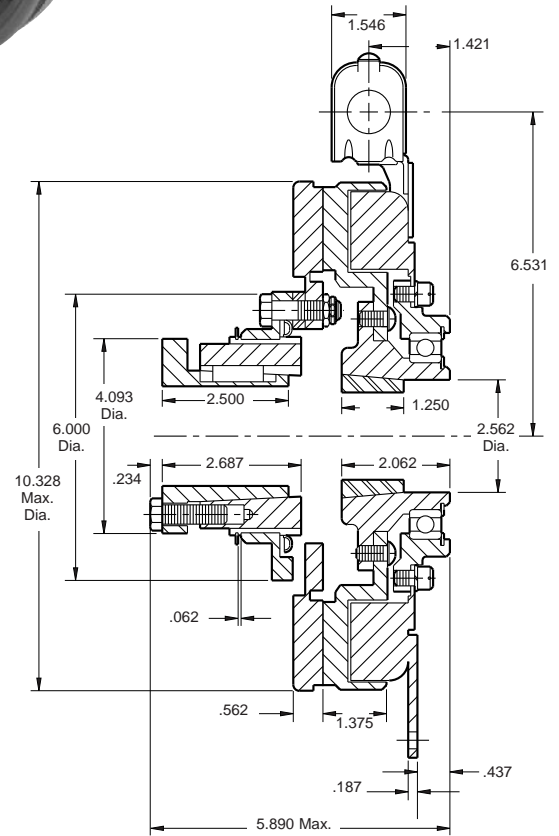

Armature Shaft	.750 – 2.687
Rotor Shaft	.500 – 2.000
Static Torque	240 lb. ft.
Maximum Speed	2,500 rpm
Standard Voltage	D.C. 6, 24, 90

Customer Shall Maintain:

1. Armature mounting shaft concentric with field and rotor mounting shaft within .006 T.I.R.
2. Angular alignment of shafts within 1/2 degree.

All dimensions are nominal unless otherwise noted.

Information on inertia and weights begins on page 239. Coil data is on pages 250 and 251.



Clutch Coupling

SFC-1000 Bearing Mounted

Drawing I-25598

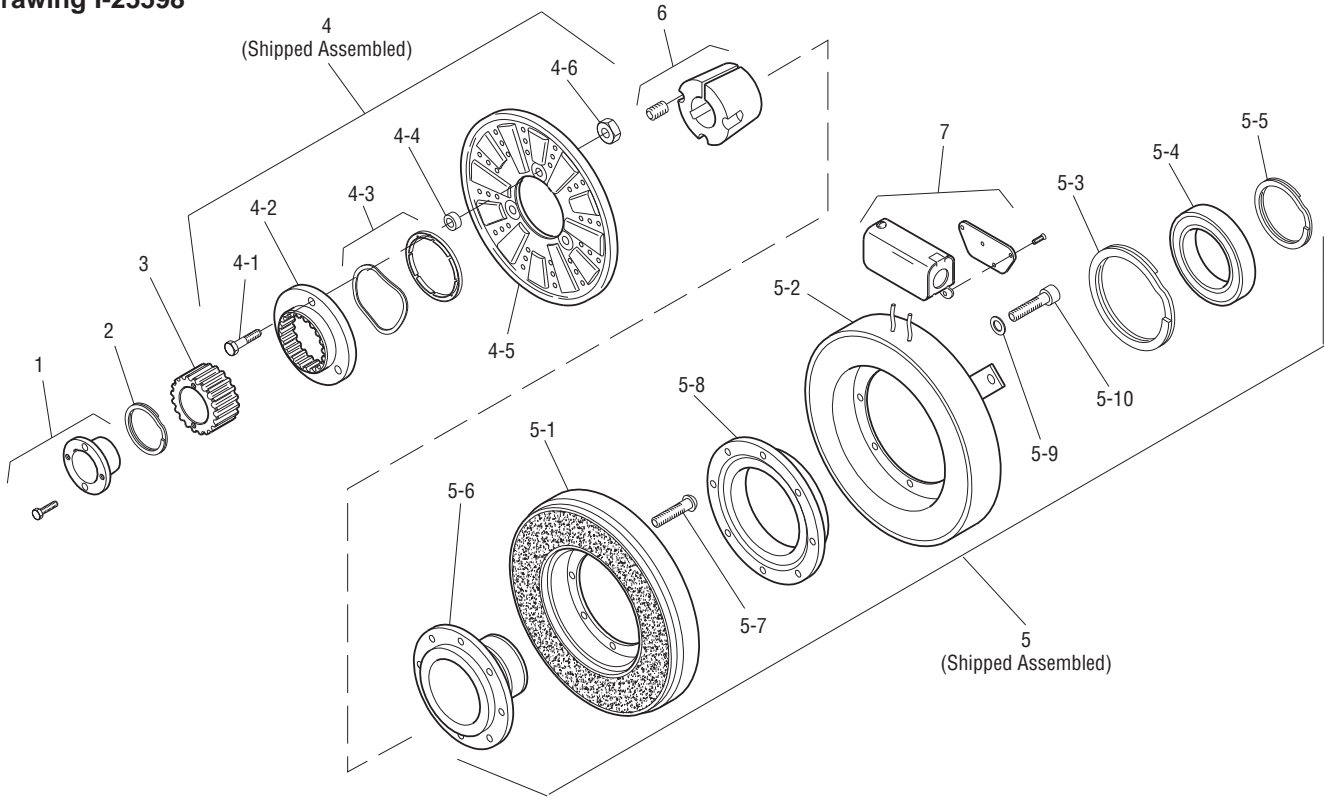

Item	Description	Part Number	Qty.
1	Bushing*		1
	3/4" to 2-11/16" Bore	180-0026 to 180-0057	
2	Retainer Ring	748-0007	1
3	Splined Hub	540-0062	1
4	Armature & Splined Adapter	5202-111-001	1
4-1	Capscrew	797-0341	3
4-2	Splined Adapter	104-0009	1
4-3	Autogap Accessory	5322-101-004	1
4-4	Spacer	748-0333	3
4-5	Armature	5322-111-036	1
4-6	Locknut	661-0004	3
5	Field & Rotor Assembly		1
	6 Volt	5202-452-012	
	24 Volt	5202-452-014	
	90 Volt	5202-452-015	
5-1	Rotor		1
	Standard Friction Material	5202-751-003	
	†Optional LK Facing	5202-751-007	
5-2	Field & Bearing Assembly		1
	6 Volt	5202-451-040	
	24 Volt	5202-451-042	
	90 Volt	5202-451-043	
5-3	Retainer Ring	748-0116	1
5-4	Ball Bearing	166-1046	1

Item	Description	Part Number	Qty.
5-5	Retainer Ring	748-0582	1
5-6	Rotor Hub	540-1300	1
5-7	Buttonhead Capscrew	797-1261	6
5-8	Ring Adapter	748-1047	1
5-9	Lockwasher	950-0359	6
5-10	Socket Head Capscrew	797-0422	6
6	Bushing*		1
	1/2" to 2" Bore	180-0155 to 180-0179	
7	Conduit Box	5200-101-012	1

How to Order:

1. Specify Bore Size for Items 1 and 6.
2. Specify Voltage for Item 5.
3. See Controls Section.

Example:

SFC-1000 Clutch Coupling per I-25598 - 90 Volt, 1" Bore

These units, when used in conjunction with the correct Warner Electric conduit box, meet the standards of UL508 and are listed under guide card #NMTR, file #59164. These units are CSA certified under file #LR11543.

*See page 252 for specific part numbers.

Refer to Service Manual P-207.

†Optional LK facing available. For more information, see page 232.

Clutch Coupling

SFC-1225 Flange Mounted

See page 252 for details on bushings.

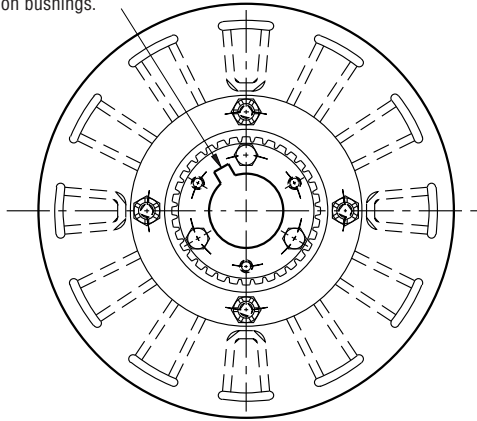
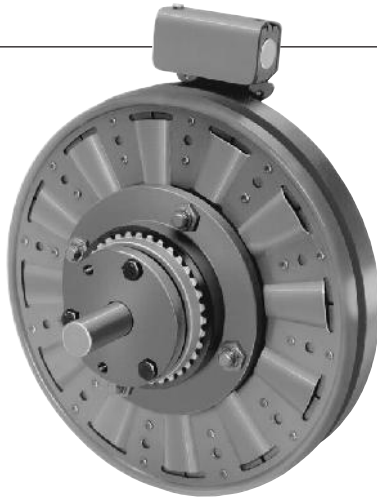

ARMATURE VIEW

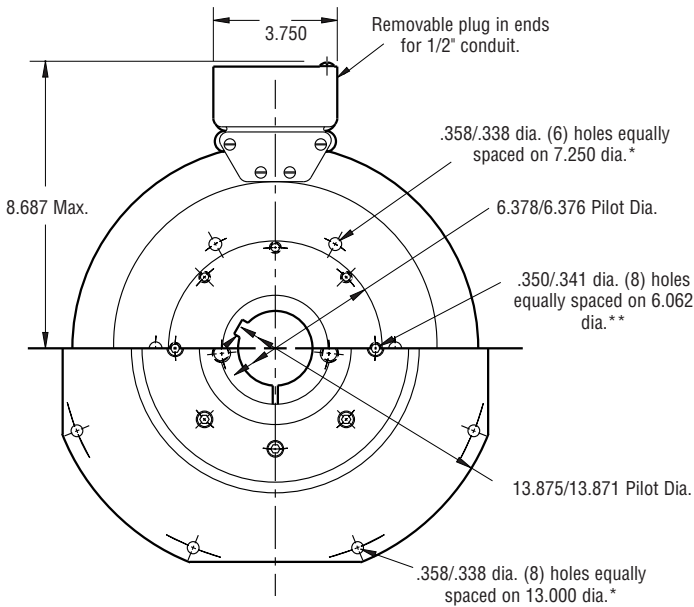

FIELD VIEW
(Inside & Outside Mounted)

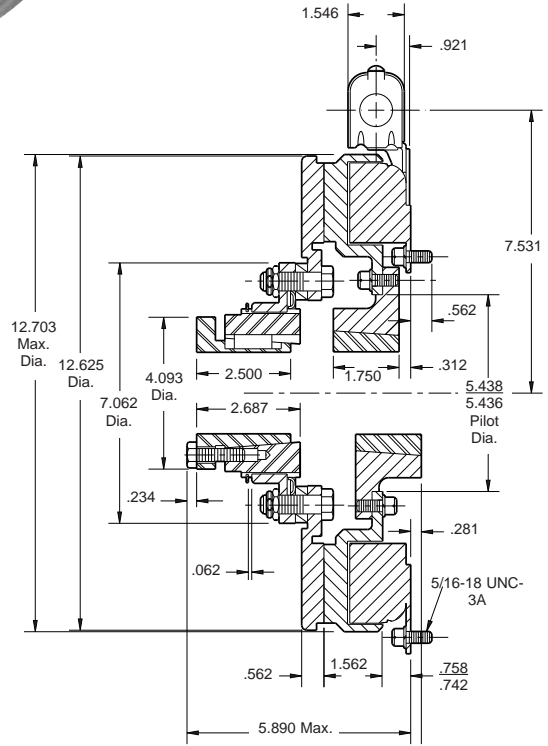

* Mounting holes are within .010 of true position relative to pilot diameter.

** Mounting holes are within .008 of true position relative to pilot diameter.

Customer Shall Maintain:

1. Concentricity of field mounting pilot diameter with rotor mounting shaft within .006 T.I.R.
2. Squareness of field mounting face with rotor mounting shaft within .006 T.I.R. measured at field mounting bolt circle.
3. Rotor mounting shaft concentric with armature mounting shaft within .006 T.I.R.
4. Angular alignment of shafts within 1/2 degree.

When Hub is Furnished by Customer:

Rotor mounting pilot diameter must be concentric with rotor mounting shaft within .006 T.I.R.

Armature Shaft	.750 – 2.687
Rotor Shaft	.500 – 2.500
Static Torque	465 lb. ft.
Maximum Speed	3,000 rpm
Standard Voltage	D.C. 6, 24, 90

All dimensions are nominal unless otherwise noted.

Information on inertia and weights begins on page 239. Coil data is on pages 250 and 251.



Clutch Coupling

SFC-1225 Flange Mounted

Drawing I-25604

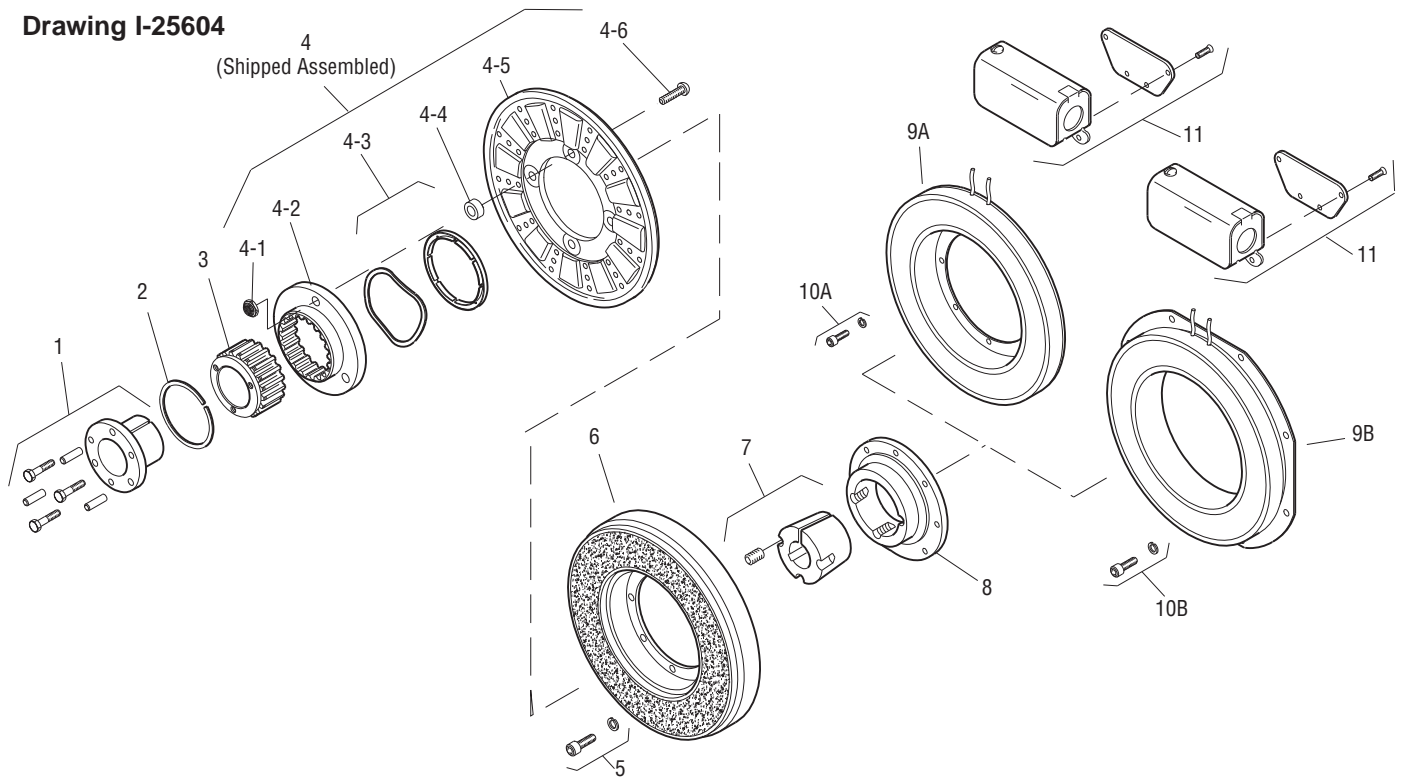

Item	Description	Part Number	Qty.
1	Bushing*		1
	3/4" to 2-11/16" Bore	180-0026 to 180-0057	
2	Retainer Ring	748-0005	1
3	Splined Hub	540-0064	1
4	Armature & Splined Adapter	5203-111-001	1
4-1	Locknut	661-0004	4
4-2	Splined Adapter	104-0010	1
4-3	Autogap Accessory	5323-101-002	1
4-4	Spacer	266-0004	4
4-5	Armature	5323-111-034	1
4-6	Screw	797-0356	4
5	Mounting Accessory	5321-101-002	2
6	Rotor		1
	Standard Friction Material	5203-751-001	
	†Optional LK Facing	5203-751-004	
7	Bushing*		1
	1/2" to 2-1/2" Bore	180-0185 to 180-0217	
8	Rotor Hub	540-0318	1
9A	Field - Inside Mounted		1
	6 Volt	5203-451-002	
	24 Volt	5203-451-006	
	90 Volt	5203-451-005	
9B	Field - Outside Mounted		1
	6 Volt	5203-451-010	
	24 Volt	5203-451-013	
	90 Volt	5203-451-011	

Item	Description	Part Number	Qty.
10A	Mounting Accessory - I.M.	5321-101-001	1
10B	Mounting Accessory - O.M.	5321-101-002	2
11	Conduit Box	5200-101-012	1

How to Order:

1. Specify Bore Size for Item 1.
2. Specify Bore Size for Item 7.
3. Specify Voltage for Item 9A or 9B.
4. Specify Inside or Outside Mounted for Item 5.
5. Specify Inside Mounted for Items 9A and 10A or Outside Mounted for Items 9B and 10B.
6. See Controls Section.

Example:

SFC-1225 Clutch Coupling per I-25604 - 90 Volt, Inside Mounted, 1-1/2" Bore (Item 1), 1-3/4" Bore (Item 7).

These units, when used in conjunction with the correct Warner Electric conduit box, meet the standards of UL508 and are listed under guide card #NMTR, file #59164. These units are CSA certified under file #LR11543.

*See page 252 for specific part numbers.

Refer to Service Manual P-207.

†Optional LK facing available. For more information, see page 232.

Clutch Coupling

SFC-1225 Bearing Mounted



See page 252 for details on bushings.

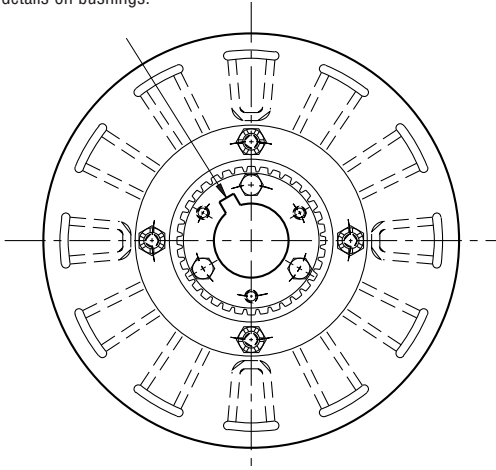

ARMATURE VIEW

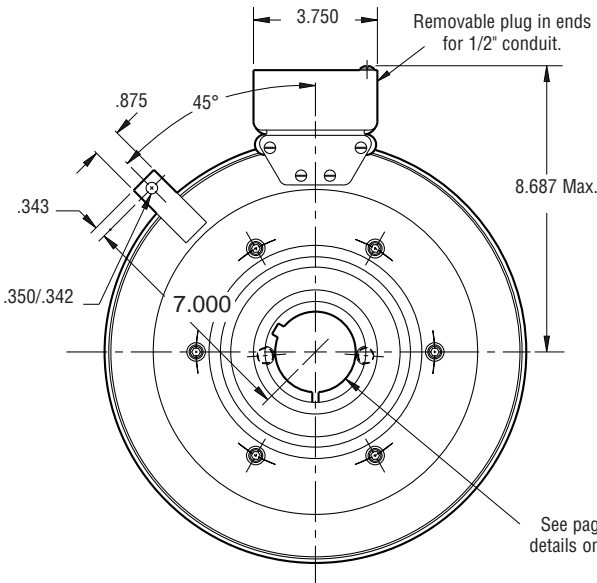

FIELD VIEW

See page 252 for details on bushings.

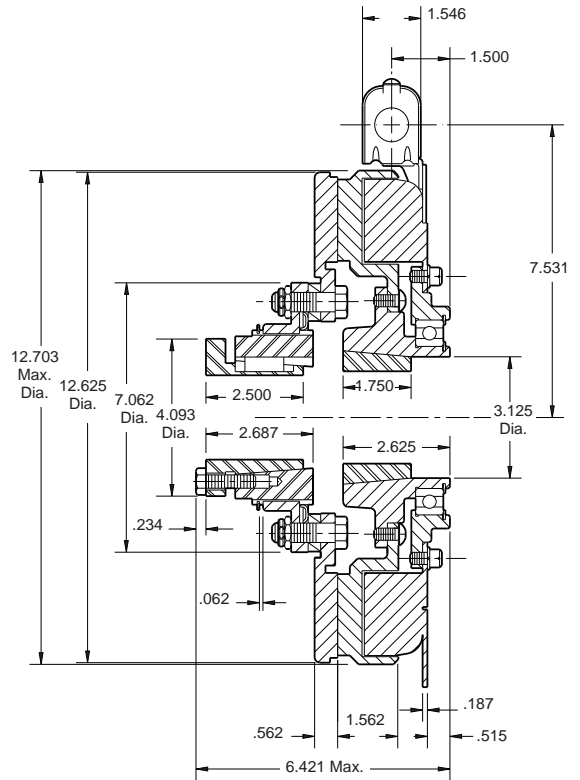

Armature Shaft	.750 – 2.687
Rotor Shaft	.500 – 2.500
Static Torque	465 lb. ft.
Maximum Speed	2,200 rpm
Standard Voltage	D.C. 6, 24, 90

Customer Shall Maintain:

1. Armature mounting shaft concentric with field and rotor mounting shaft within .006 T.I.R.
2. Angular alignment of shafts within 1/2 degree.

All dimensions are nominal unless otherwise noted.

Information on inertia and weights begins on page 239. Coil data is on pages 250 and 251.



Clutch Coupling

SFC-1225 Bearing Mounted

Drawing I-25623

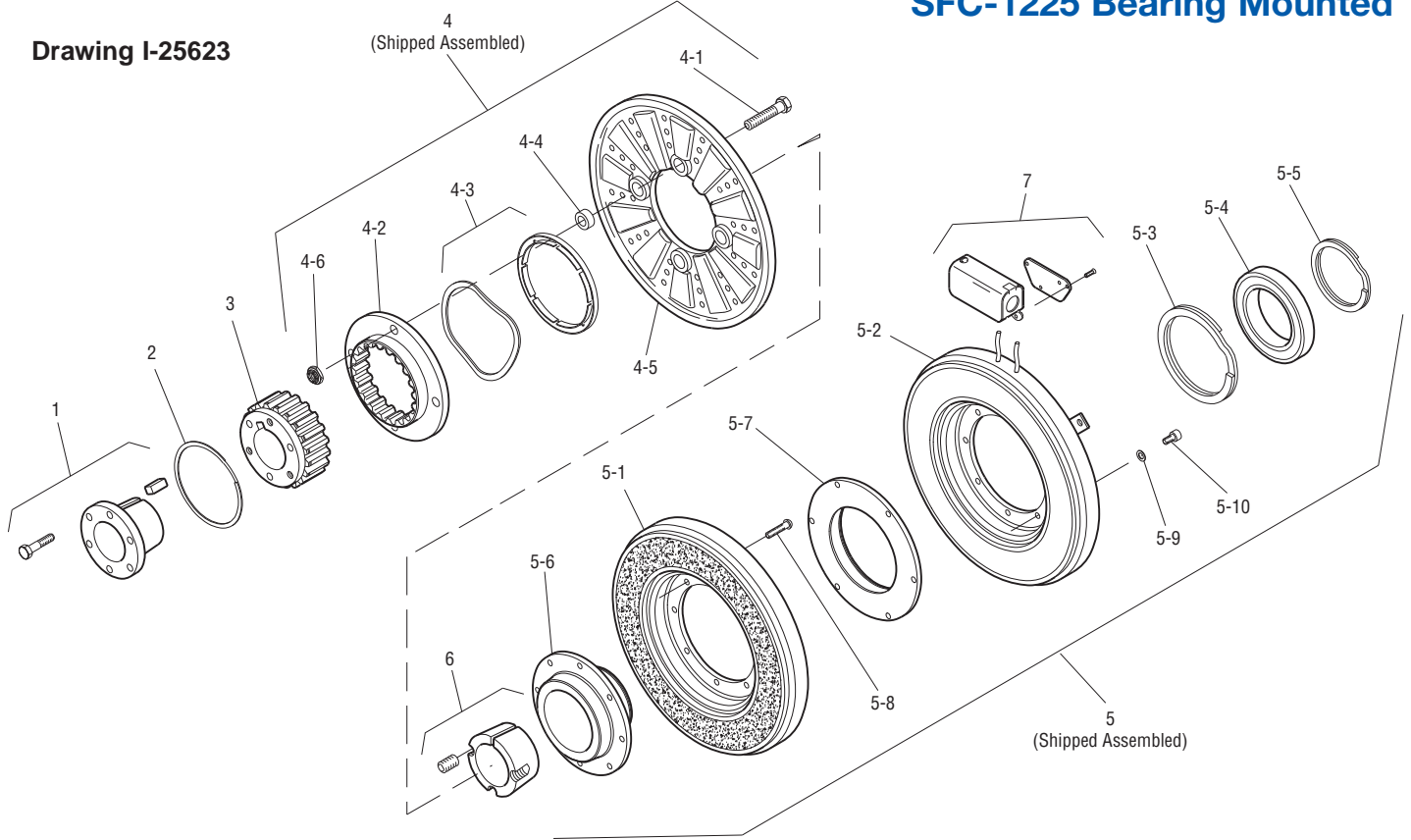

Item	Description	Part Number	Qty.
1	Bushing*		1
	3/4" to 2-11/16" Bore	180-0026 to 180-0057	
2	Retainer Ring	748-0005	1
3	Splined Hub	540-0064	1
4	Armature & Splined Adapter	5203-111-001	1
4-1	Capscrew	797-0356	4
4-2	Splined Adapter	104-0010	1
4-3	Autogap Accessory	5323-101-002	1
4-4	Spacer	266-0004	4
4-5	Armature	5323-111-034	1
4-6	Locknut	661-0005	4
5	Field & Rotor Assembly		1
	6 Volt	5203-452-009	
	24 Volt	5203-452-011	
	90 Volt	5203-452-012	
5-1	Rotor		1
	Standard Friction Material	5203-751-001	
	†Optional LK Facing	5203-751-004	
5-2	Field		1
	6 Volt	5203-451-034	
	24 Volt	5203-451-036	
	90 Volt	5203-451-037	
5-3	Retainer Ring	748-0119	1
5-4	Ball Bearing	166-1047	1

Item	Description	Part Number	Qty.
5-5	Retainer Ring	748-0011	1
5-6	Rotor Hub	540-1304	1
5-7	Ring Adapter	748-0591	1
5-8	Buttonhead Capscrew	797-1261	6
5-9	Lockwasher	950-0359	6
5-10	Sockethead Capscrew	797-0424	6
6	Bushing*		1
	1/2" to 2-1/2" Bore	180-0185 to 180-0217	
7	Conduit Box	5200-101-012	1

How to Order:

1. Specify Bore Size for Item 1.
2. Specify Bore Size for Item 6.
3. Specify Voltage for Item 5.
4. See Controls Section.

Example:

SFC-1225 Clutch Coupling per I-25623 - 90 Volt, 1" Bore

These units, when used in conjunction with the correct Warner Electric conduit box, meet the standards of UL508 and are listed under guide card #NMTR, file #59164. These units are CSA certified under file #LR11543.

*See page 252 for specific part numbers.

Refer to Service Manual P-207.

†Optional LK facing available. For more information, see page 232.

Clutch Coupling

SFC-1525 Flange Mounted

See page 252 for details on bushings.

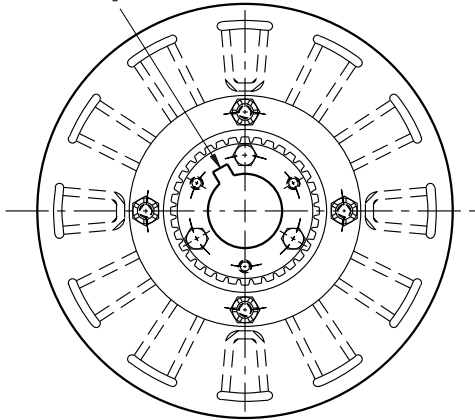

ARMATURE VIEW

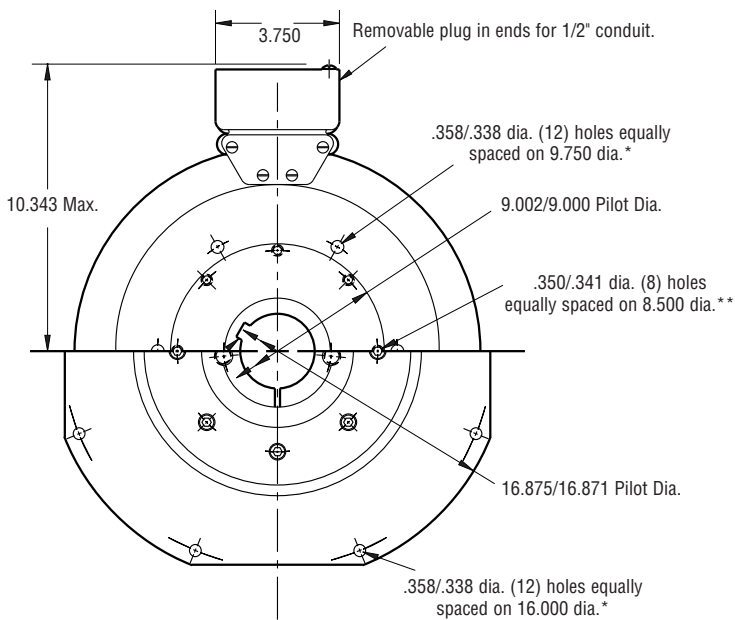

FIELD VIEW

(Inside & Outside Mounted)

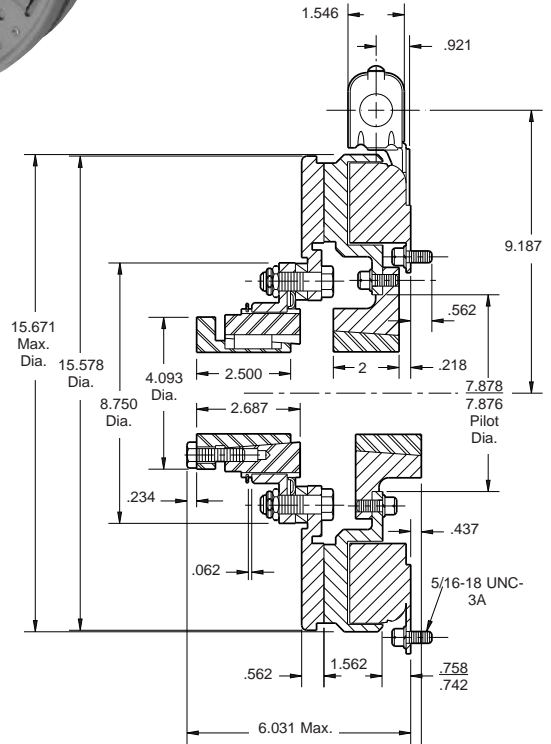

* Mounting holes are within .010 of true position relative to pilot diameter.

** Mounting holes are within .008 of true position relative to pilot diameter.

Customer Shall Maintain:

1. Concentricity of field mounting pilot diameter with rotor mounting shaft within .006 T.I.R.
2. Squareness of field mounting face with rotor mounting shaft within .006 T.I.R. measured at field mounting bolt circle.
3. Rotor mounting shaft concentric with armature mounting shaft within .006 T.I.R.
4. Angular alignment of shafts within 1/2 degree.

When Hub is Furnished by Customer:

Rotor mounting pilot diameter must be concentric with rotor mounting shaft within .006 T.I.R.

Armature Shaft	.750 – 2.687
Rotor Shaft	.937 – 3.000
Static Torque	700 lb. ft.
Maximum Speed	2,000 rpm
Standard Voltage	D.C. 6, 24, 90

All dimensions are nominal unless otherwise noted.

Information on inertia and weights begins on page 239. Coil data is on pages 250 and 251.



Clutch Coupling

SFC-1525 Flange Mounted

Drawing I-25630

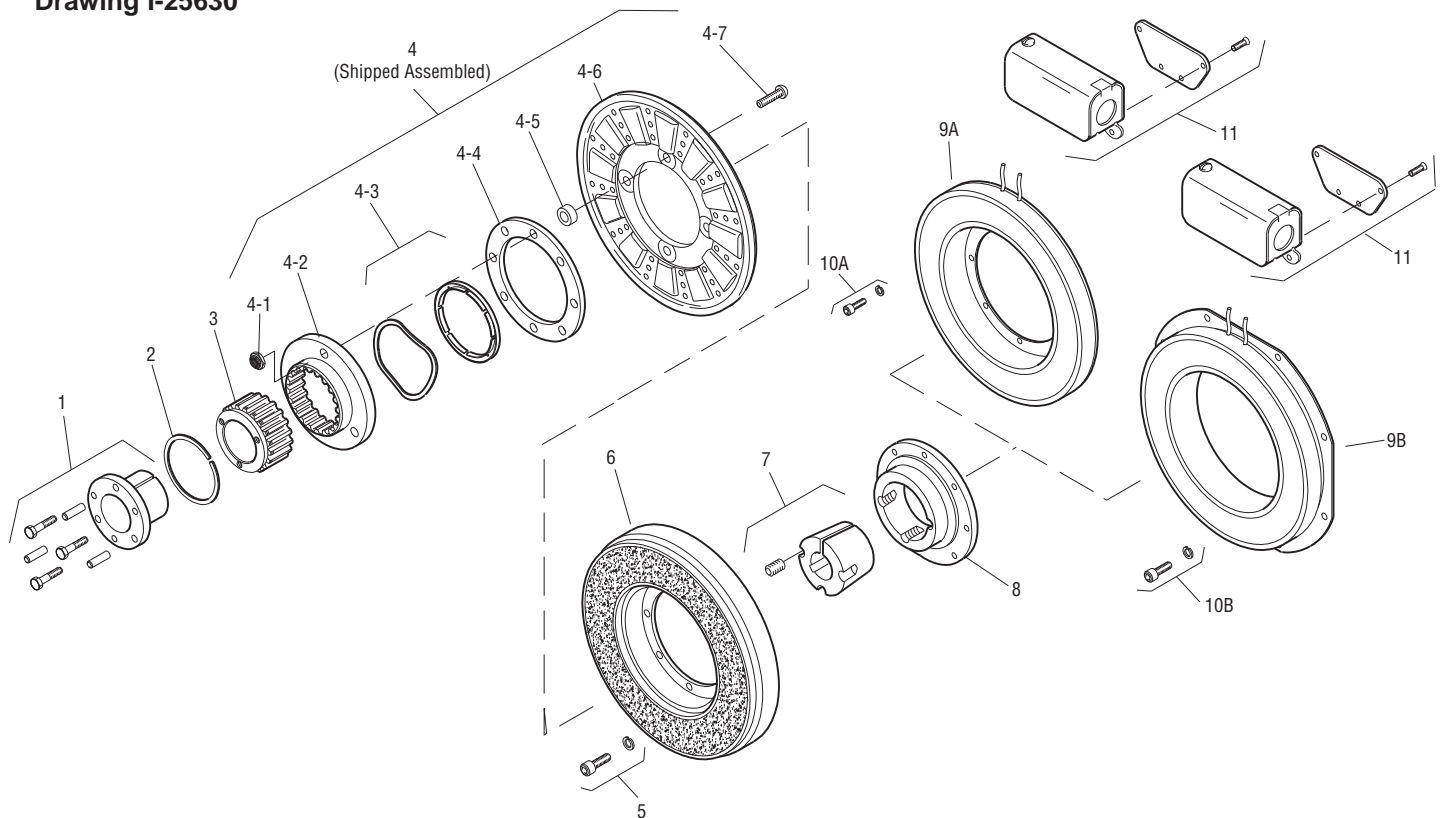

Item	Description	Part Number	Qty.
1	Bushing*		1
	3/4" to 2-11/16" Bore	180-0026 to 180-0057	
2	Retainer Ring	748-0005	1
3	Splined Hub	540-0064	1
4	Armature & Splined Adapter	5204-111-004	1
4-1	Locknut	661-0004	8
4-2	Splined Adapter	104-0011	1
4-3	Autogap Accessory	5323-101-002	1
4-4	Retainer Plate	686-0003	1
4-5	Spacer	748-0333	8
4-6	Armature	5324-111-034	1
4-7	Screw	797-0342	8
5	Mounting Accessory	5321-101-002	2
6	Rotor		1
	Standard Friction Material	5204-751-002	
	†Optional LK Facing	5204-751-004	
7	Bushing*		1
	15/16" to 3" Bore	180-0223 to 180-0256	
8	Rotor Hub	540-0004	1
9A	Field - Inside Mounted		1
	6 Volt	5204-451-013	
	24 Volt	5204-451-015	
	90 Volt	5204-451-016	

Item	Description	Part Number	Qty.
9B	Field - Outside Mounted		1
	6 Volt	5204-451-055	
	24 Volt	5204-451-056	
	90 Volt	5204-451-057	
10A	Mounting Accessory - I.M.	5321-101-001	2
10B	Mounting Accessory - O.M.	5321-101-001	2
11	Conduit Box	5200-101-012	1

How to Order:

1. Specify Bore Size for Item 1.
2. Specify Bore Size for Item 7.
3. Specify Voltage for Item 9A or 9B.
4. Specify Inside Mounted for Items 9A and 10A or Outside Mounted for Items 9B and 10B.
5. See Controls Section.

Example:

SFC-1525 Clutch Coupling per I-25630 - 90 Volt, Inside Mounted, 1-1/2" Bore (Item 1), 1-3/4" Bore (Item 7).

These units, when used in conjunction with the correct Warner Electric conduit box, meet the standards of UL508 and are listed under guide card #NMTR, file #59164. These units are CSA certified under file #LR11543.

*See page 252 for specific part numbers.

Refer to Service Manual P-207.

†Optional LK facing available. For more information, see page 232.

Clutch Coupling

SFC-1525 Bearing Mounted

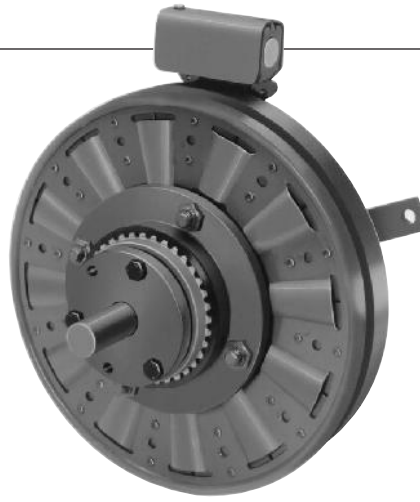

See page 252 for details on bushings.

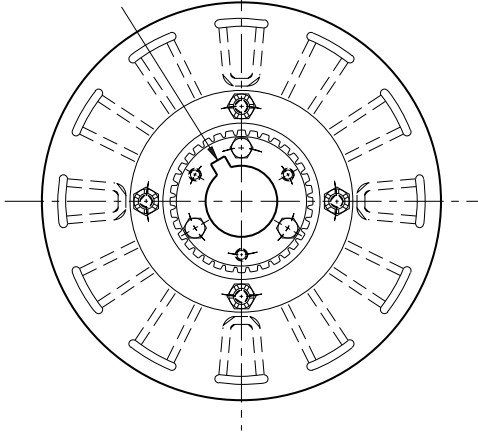

ARMATURE VIEW

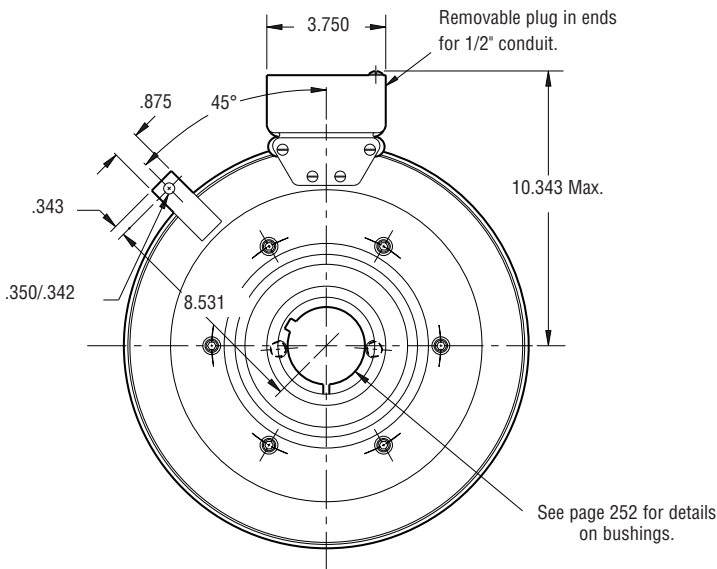

FIELD VIEW

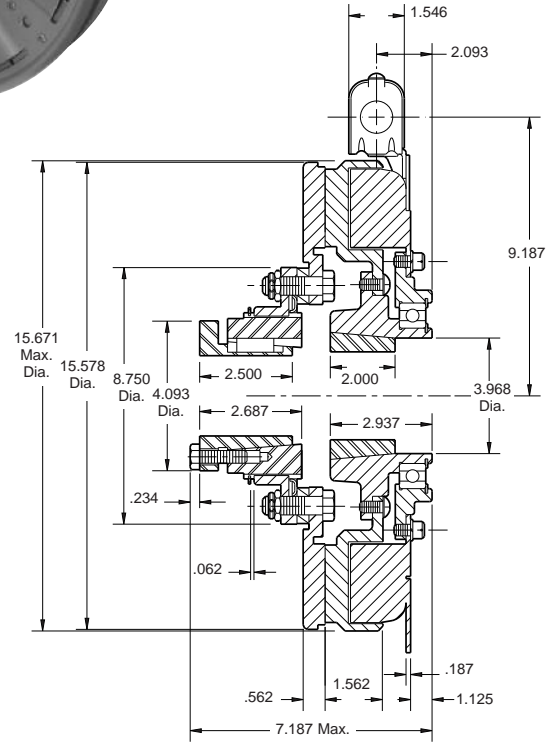

Armature Shaft	.750 – 2.687
Rotor Shaft	.937 – 3.000
Static Torque	700 lb. ft.
Maximum Speed	1,800 rpm
Standard Voltage	D.C. 6, 24, 90

All dimensions are nominal unless otherwise noted.

Information on inertia and weights begins on page 239. Coil data is on pages 250 and 251.

Customer Shall Maintain:

1. Armature mounting shaft concentric with field and rotor mounting shaft within .006 T.I.R.
2. Angular alignment of shafts within 1/2 degree.



Clutch Coupling

SFC-1525 Bearing Mounted

Drawing I-25641

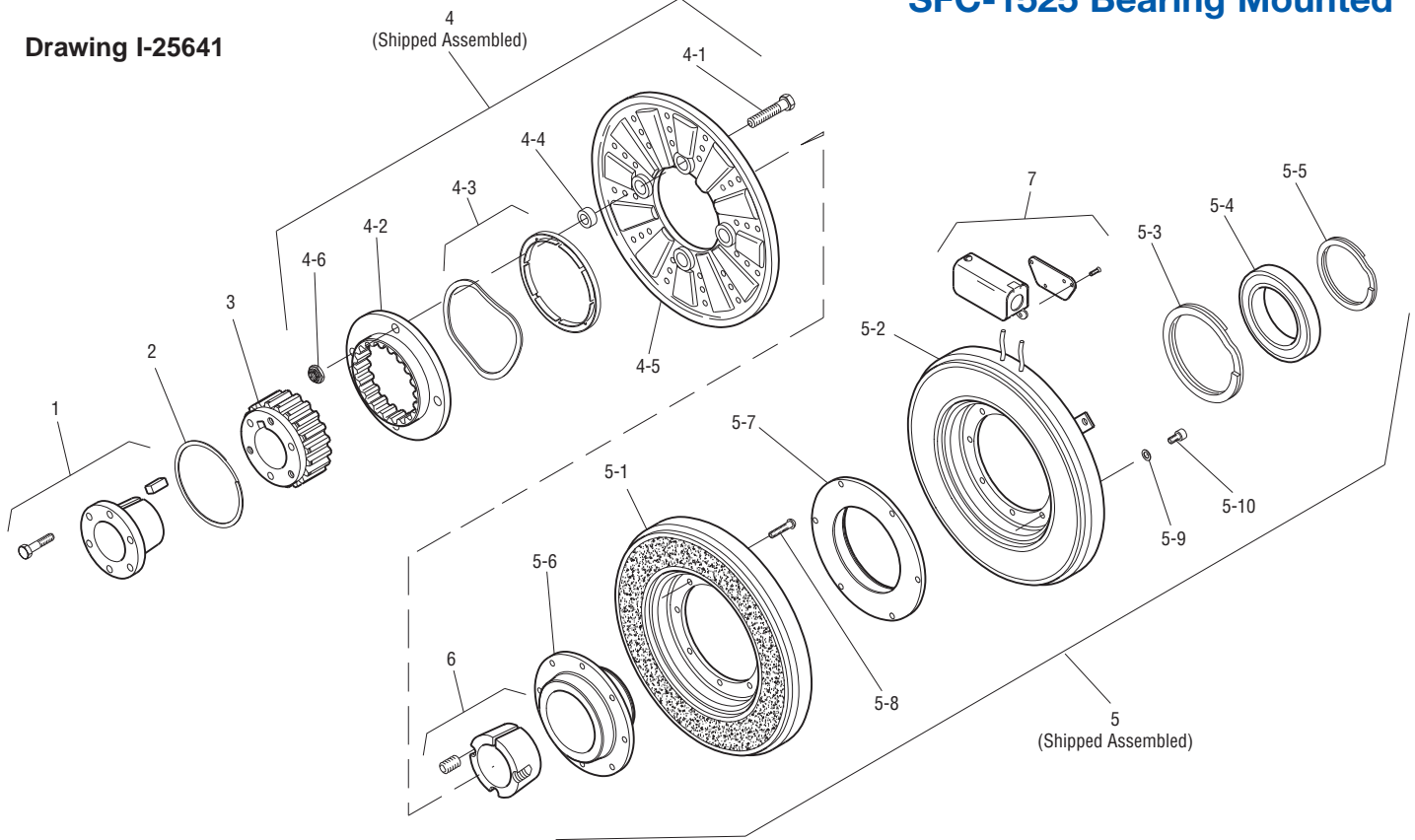

Item	Description	Part Number	Qty.
1	Bushing*		1
	3/4" to 2-11/16" Bore	180-0026 to 180-0057	
2	Retainer Ring	748-0005	1
3	Splined Hub	540-0064	1
4	Armature & Splined Adapter	5204-111-004	1
4-1	Capscrow	797-0342	8
4-2	Splined Adapter	104-0011	1
4-3	Autogap Accessory	5323-101-002	1
4-4	Spacer	748-0333	8
4-5	Armature	5324-111-034	1
4-6	Locknut	661-0004	8
5	Field & Rotor Assembly		1
	6 Volt	5204-452-009	
	24 Volt	5204-452-011	
	90 Volt	5204-452-012	
5-1	Rotor		1
	Standard Friction Material	5204-751-002	
	†Optional LK Facing	5204-751-004	
5-2	Field		1
	6 Volt	5204-451-084	
	24 Volt	5204-451-086	
	90 Volt	5204-451-087	
5-3	Retainer Ring	748-0114	1
5-4	Ball Bearing	166-0163	1

Item	Description	Part Number	Qty.
5-5	Retainer Ring	748-0583	1
5-6	Rotor Hub	540-1306	1
5-7	Ring Adapter	748-1048	1
5-8	Buttonhead Capscrow	797-1261	8
5-9	Lockwasher	950-0359	6
5-10	Sockethead Capscrow	797-0424	6
6	Bushing*		1
	15/16" to 3" Bore	180-0223 to 180-0256	
7	Conduit Box	5200-101-012	1

How to Order:

1. Specify Bore Size for Item 1.
2. Specify Bore Size for Item 6.
3. Specify Voltage for Item 5.
4. See Controls Section.

Example:

SFC-1525 Clutch Coupling per I-25641 - 90 Volt, 1" Bore

These units, when used in conjunction with the correct Warner Electric conduit box, meet the standards of UL508 and are listed under guide card #NMTR, file #59164. These units are CSA certified under file #LR11543.

*See page 252 for specific part numbers.

Refer to Service Manual P-207.

†Optional LK facing available. For more information, see page 232.

Clutch Coupling, Hi-Torque

SFC-1525 H.T. Flange Mounted

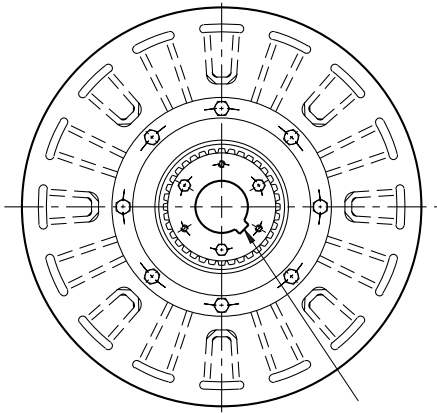

See page 252 for details on bushings.

ARMATURE VIEW

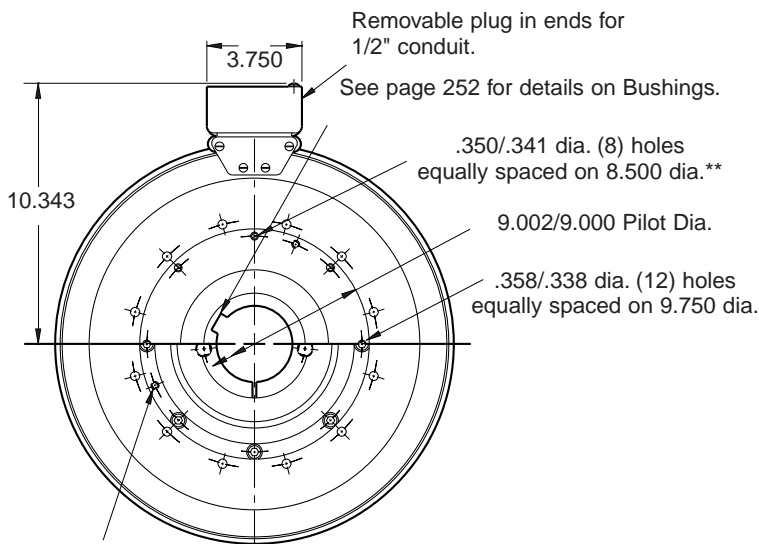

FIELD VIEW

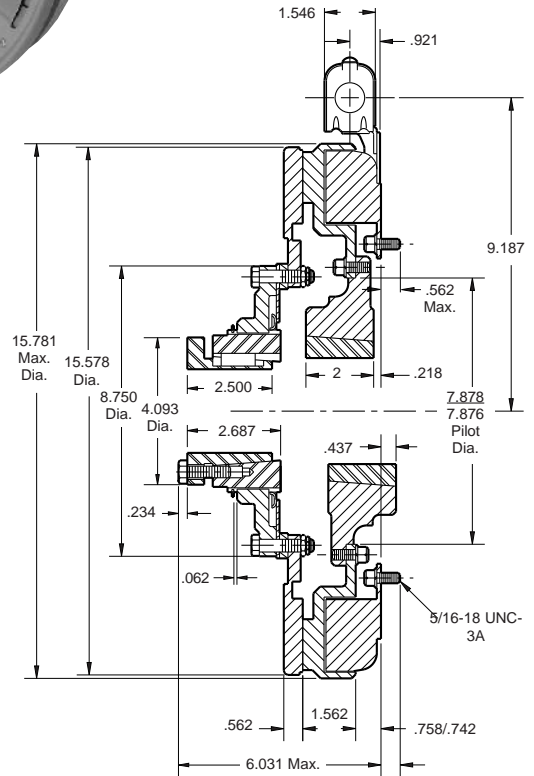

*Mounting holes are within .010 of true position relative to pilot diameter.

**Mounting holes are within .008 of true position relative to pilot diameter.

Customer Shall Maintain:

1. Concentricity of field mounting pilot diameter with rotor mounting shaft within .006 T.I.R.
2. Squareness of field mounting face with rotor mounting shaft within .006 T.I.R. measured at field mounting bolt circle.
3. Rotor mounting shaft concentric with armature mounting shaft within .006 T.I.R.
4. Angular alignment of shafts within 1/2 degree.

When Hub is Furnished by Customer:

Rotor mounting pilot diameter must be concentric with rotor mounting shaft within .006 T.I.R.

Armature Shaft	.750 – 2.687
Rotor Shaft	.937 – 3.000
Static Torque	1,350 lb.ft.
Maximum Speed	2,000 rpm
Standard Voltage	D.C. 6, 90

All dimensions are nominal unless otherwise noted.

Information on inertia and weights begins on page 239. Coil data is on pages 250 and 251.



Clutch Coupling, Hi-Torque

SFC-1525 H.T Flange Mounted.

Drawing I-25631

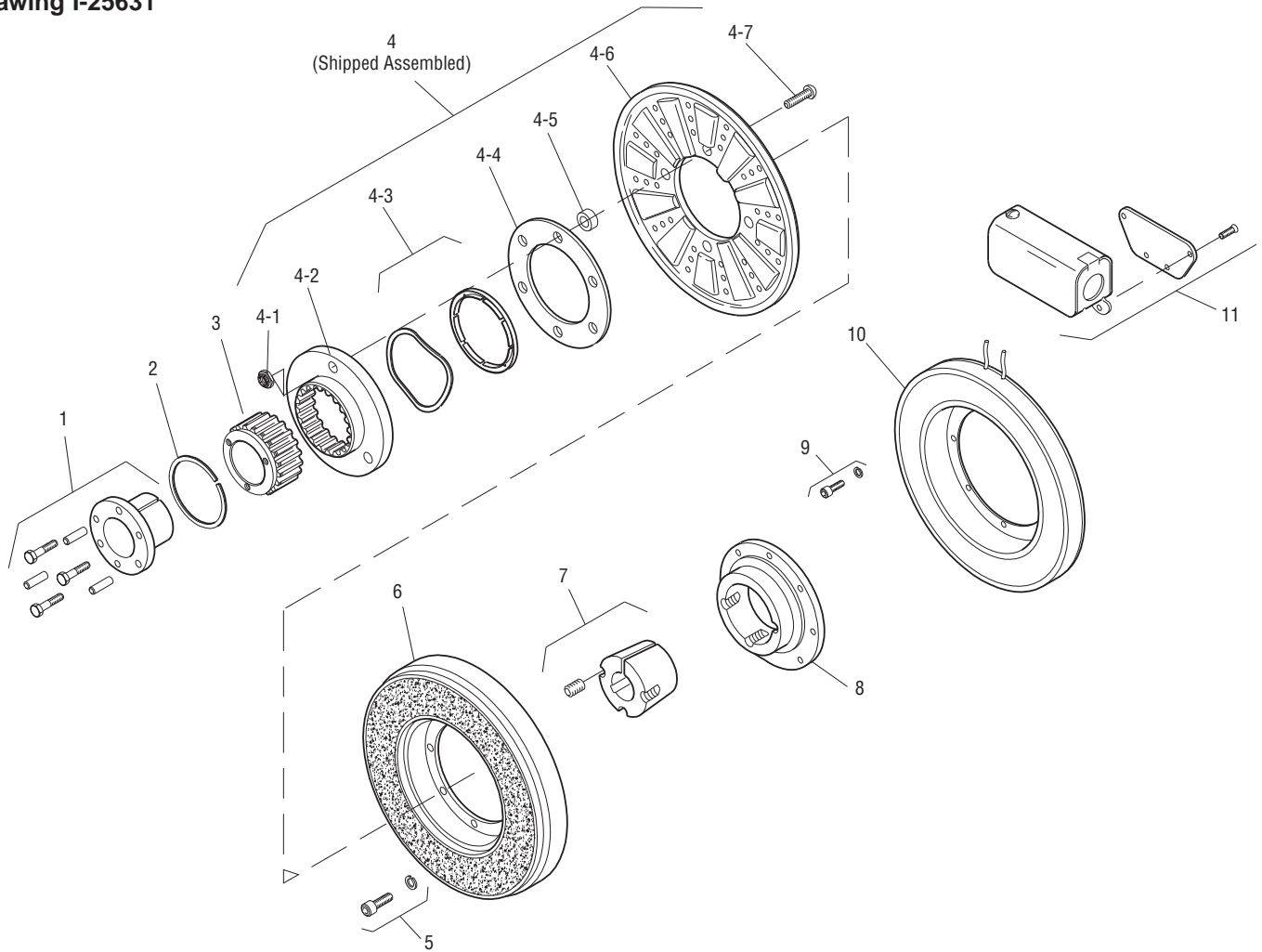

Item	Description	Part Number	Qty.
1	Bushing*		1
	3/4" to 2-11/16" Bore	180-0026 to 180-0057	
2	Retainer Ring	748-0005	1
3	Splined Hub	540-0064	1
4	Armature & Splined Adapter	5204-111-004	1
4-1	Locknut	661-0004	8
4-2	Splined Adapter	104-0011	1
4-3	Autogap Accessory	5323-101-002	1
4-4	Retainer Plate	686-0003	1
4-5	Spacer	748-0333	8
4-6	Armature	5324-111-034	1
4-7	Screw	797-0342	8
5	Mounting Accessory	5321-101-002	2
6	Rotor	5204-751-001	1
7	Bushing*		1
	15/16" to 3" Bore	180-0223 to 180-0256	
8	Rotor Hub	540-0004	1
9	Field - Inside Mounted		1
	90 Volt	5204-451-006	

Item	Description	Part Number	Qty.
10	Mounting Accessory - I.M.	5321-101-001	2
11	Conduit Box	5200-101-012	1

How to Order:

1. Specify Bore Size for Item 1.
2. Specify Bore Size for Item 7.
3. See Controls Section.

Example:

SFC-1525 Clutch Coupling, Hi-Torque,
per I-25631 - 90 Volt

2" Bore (Item 1), 2-1/2" Bore (Item 7)

These units, when used in conjunction with the correct Warner Electric conduit box, meet the standards of UL508 and are listed under guide card #NMTR, file #59164. These units are CSA certified under file #LR11543.

*See page 252 for specific part numbers.

Refer to Service Manual P-207.

Clutch Coupling, Hi-Torque

SFC-1525 H.T. Bearing Mounted



See page 252 for details on Bushings.

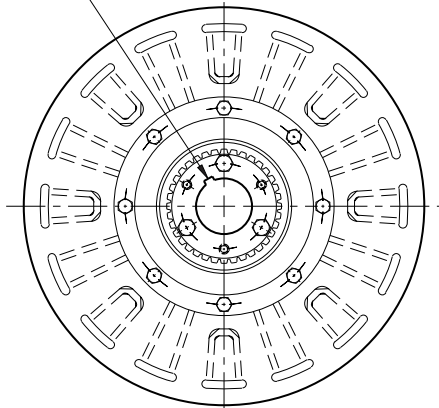

ARMATURE VIEW

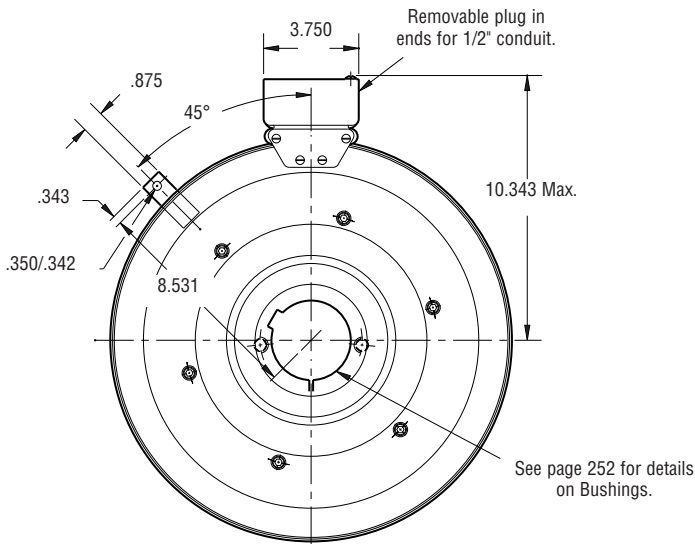

FIELD VIEW

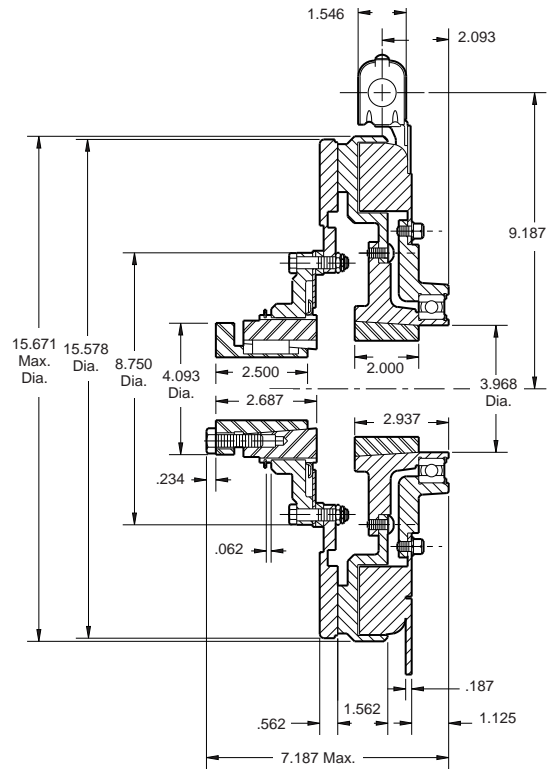

Armature Shaft	.937 – 3.000
Rotor Shaft	.750 – 2.687
Static Torque	1,350 lb.ft.
Maximum Speed	1,800 rpm
Standard Voltage	D.C. 90

All dimensions are nominal unless otherwise noted.

Information on inertia and weights begins on page 239. Coil data is on pages 250 and 251.

Customer Shall Maintain:

1. Armature mounting shaft concentric with field and rotor mounting shaft within .006 T.I.R.
2. Angular alignment of shafts within 1/2 degree.



Clutch Coupling, Hi-Torque

SFC-1525 H.T. Bearing Mounted

Drawing I-25644

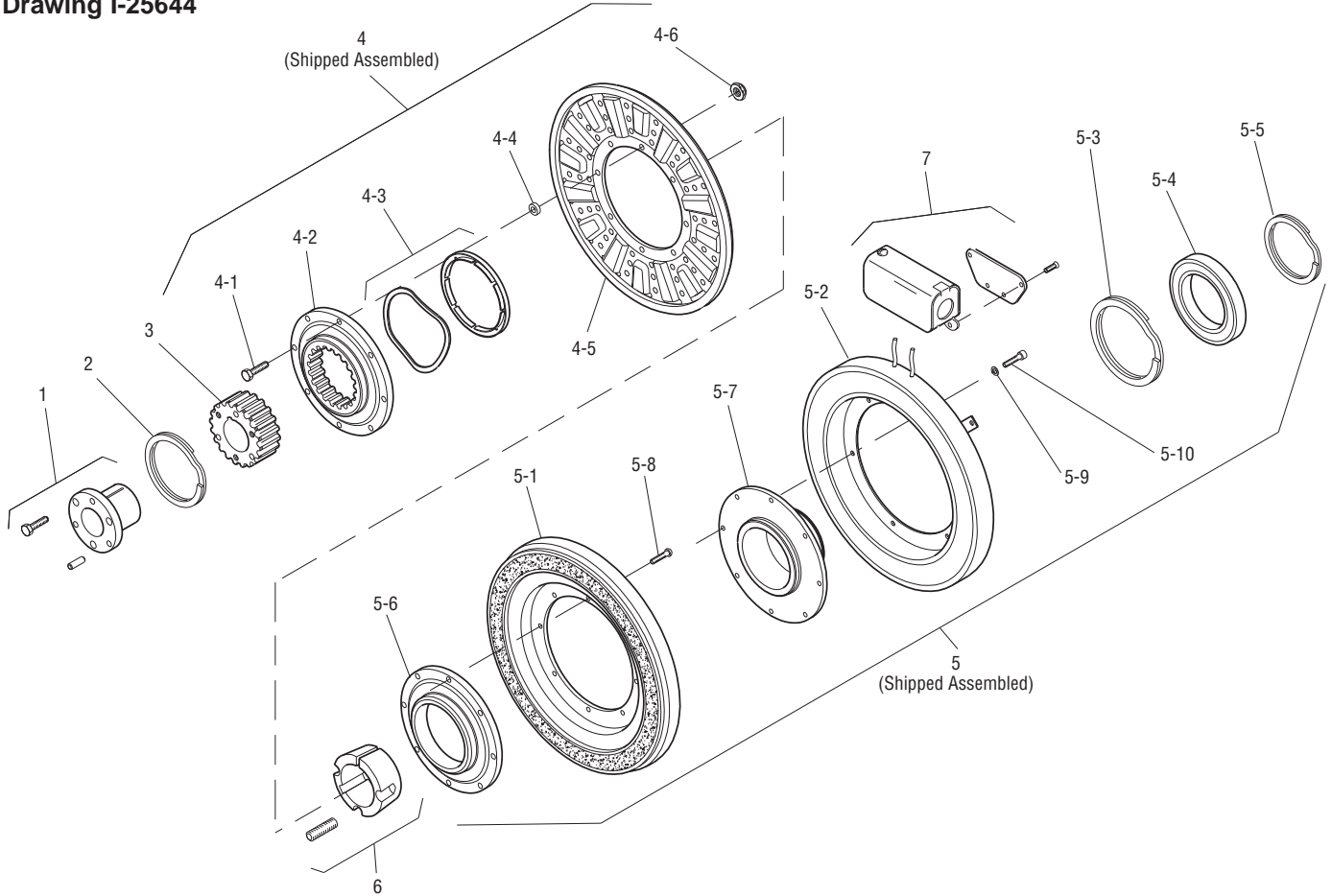

Item	Description	Part Number	Qty.
1	Bushing*		1
	3/4" to 2-11/16" Bore	180-0026 to 180-0057	
2	Retainer Ring	748-0005	1
3	Splined Hub	540-0064	1
4	Armature & Splined Adapter	5204-111-004	1
4-1	Capscrew	797-0342	8
4-2	Splined Adapter	104-0011	1
4-3	Autogap Accessory	5323-101-002	1
4-4	Spacer	748-0333	8
4-5	Armature	5324-111-034	1
4-6	Locknut	661-0004	8
5	Field & Rotor Assembly		1
	90 Volt	5204-452-015	
5-1	Rotor	5204-751-001	1
5-2	Field		1
	90 Volt	5204-451-090	
5-3	Retainer Ring	748-0114	1
5-4	Ball Bearing	166-0163	1
5-5	Retainer Ring	748-0583	1
5-6	Rotor Hub	540-1306	1
5-7	Ring Adapter	748-1048	1

Item	Description	Part Number	Qty.
5-8	Buttonhead Capscrew	797-1261	8
5-9	Lockwasher	950-0359	6
5-10	Sockethead Capscrew	797-0424	6
6	Bushing*		1
	5/16" to 3" Bore	180-0223 to 180-0256	
7	Conduit Box	5200-101-012	1

How to Order:

1. Specify Bore Size for Item 1.
2. Specify Bore Size for Item 6.
3. Specify Voltage for Item 5.
4. See Controls Section.

Example:

SFC-1525 Clutch Coupling Hi-Torque per I-25644 - 90 Volt, 1" Bore

These units, when used in conjunction with the correct Warner Electric conduit box, meet the standards of UL508 and are listed under guide card #NMTR, file #59164. These units are CSA certified under file #LR11543.

*See page 252 for specific part numbers.

Refer to Service Manual P-207.