

Clutch/Brake Coupling

PCBC-500 Normal Duty

1/2-14 NPSM Am. std. straight pipe tap.

See page 252 for details on Bushings.

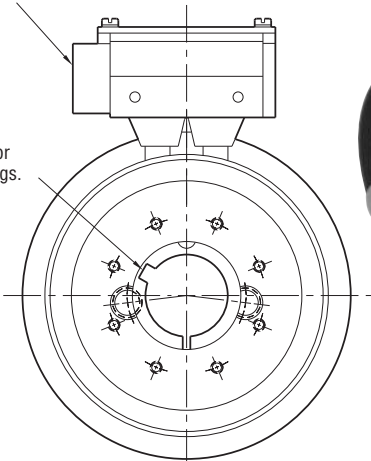

COLLECTOR RING VIEW

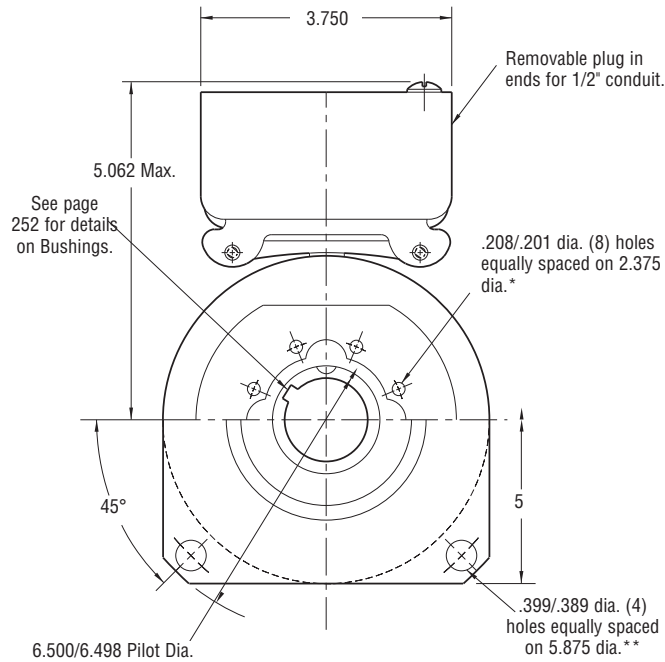
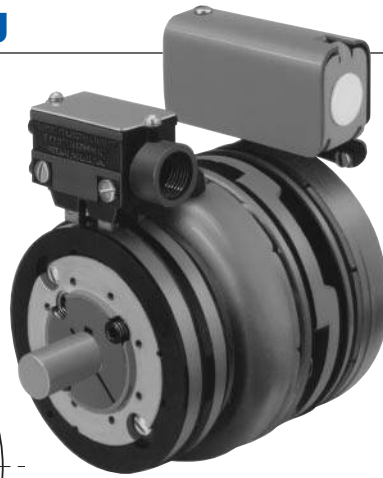

**MAGNET VIEW
(Inside & Outside Mounted)**

* Mounting holes are within .010 of true position relative to pilot diameter.

** Mounting holes are within .008 of true position relative to pilot diameter.

Customer Shall Maintain:

1. Squareness of brake mounting face with armature hub shaft within .006 T.I.R.
2. Concentricity of brake mounting pilot diameter with armature hub shaft within .010 T.I.R.
3. Concentricity of clutch magnet hub assembly shaft with armature hub shaft within .006 T.I.R.

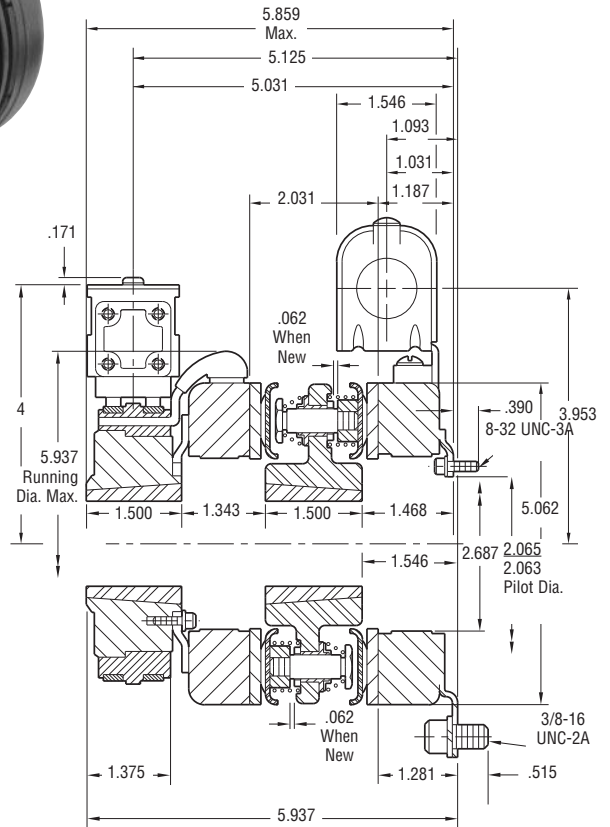

Outside Mounted Offset Backing Plate

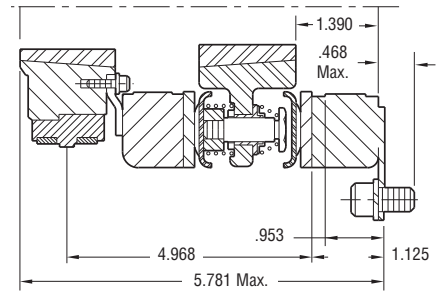

Outside Mounted Flush Backing Plate

Armature Shaft	.500 – 1.250
Magnet Shaft	.500 – 1.250
Static Torque	40 lb. ft.
Maximum Speed	5,400 rpm
Standard Voltage	D.C. 6, 24, 90

All dimensions are nominal unless otherwise noted.

Information on inertia and weights begins on page 239. Coil data is on pages 250 and 251.

Clutch/Brake Coupling

PCBC-500 Normal Duty

Drawing I-25547

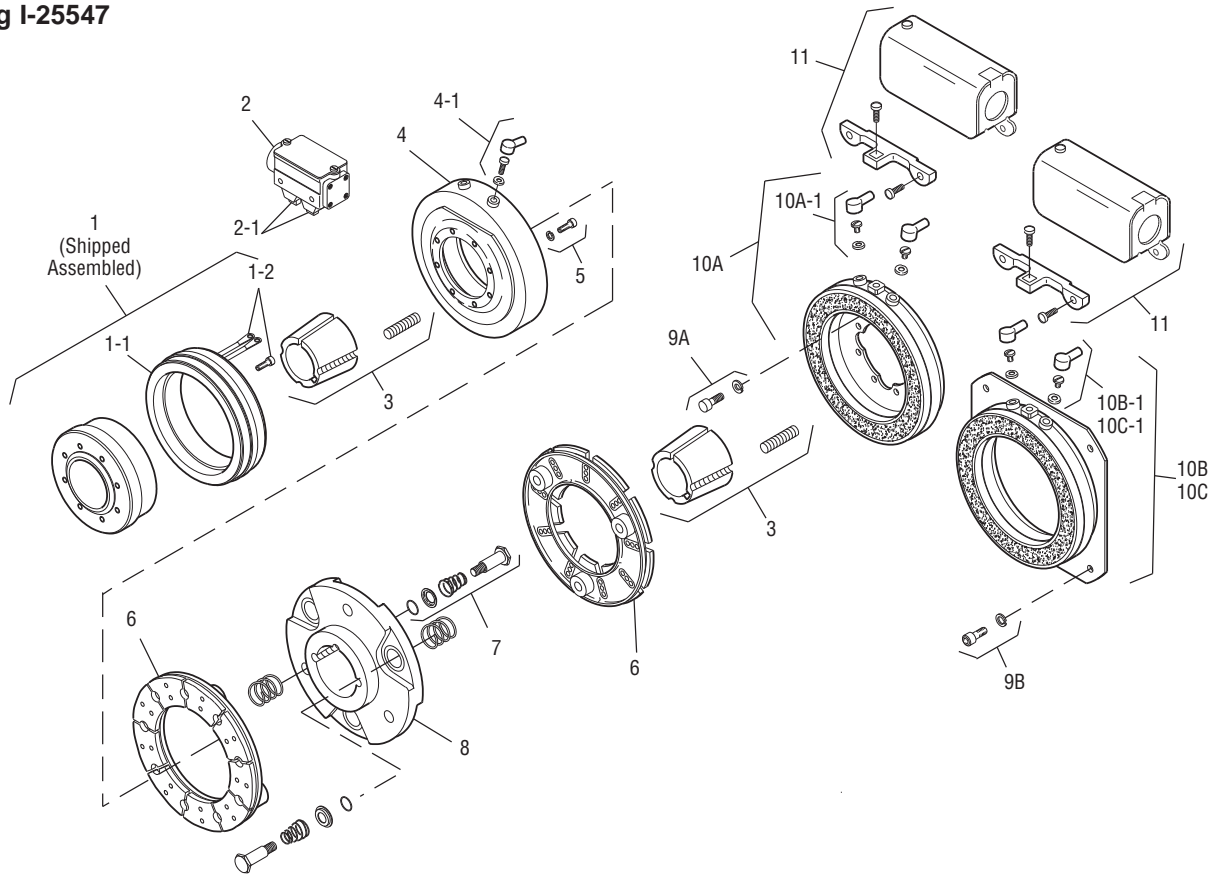

Item	Description	Part Number	Qty.
1	Magnet Hub	5300-541-001	1
1-1	Collector Ring	5300-749-001	1
1-2	Collector Ring Mounting Accessory	5300-101-002	1
2	Brushholder	5300-178-001	1
2-1	Brush	176-0001	4
3	Bushing*		2
	1/2" - 1/4" Bore	180-0116 to 180-0128	
4	Magnet, Clutch		1
	6 Volt	5300-631-002	
	24 Volt	5300-631-003	
	90 Volt	5300-631-005	
4-1	Terminal Accessory	5311-101-001	1
5	Mounting Accessory	5102-101-001	2
6	Armature	5300-111-002	2
7	Autogap Accessory	5200-101-009	6
8	Armature Hub	5300-541-004	1
9A	Mounting Accessory - I.M.	5102-101-001	2
9B	Mounting Accessory - O.M.	5300-101-008	1
10A	Magnet - I.M.		1
	6 Volt	5300-631-002	
	24 Volt	5300-631-003	
	90 Volt	5300-631-005	
10A-1	Terminal Accessory	5311-101-001	1

Item	Description	Part Number	Qty.
10B	Magnet - O.M. - Offset		1
	90 Volt	5300-631-014	
10B-1	Terminal Accessory	5311-101-001	1
10C	Magnet - O.M. - Flush		1
	6 Volt	5300-631-009	
	24 Volt	5300-631-010	
	90 Volt	5300-631-011	
10C-1	Terminal Accessory	5311-101-001	1
11	Conduit Box	5200-101-010	1

How to Order:

1. Specify Bore Size for Item 3 (two shafts).
2. Specify Voltage for Item 4 and Item 10A, 10B or 10C.
3. Specify Inside Mounted for Item 10A and Outside Mounted (Offset) for Item 10B or Outside Mounted (Flush) for Item 10C.
4. See Controls Section.

Example:

PCBC-500 Clutch Brake Coupling per I-25547 - 90 Volt, Inside Mounted, 1" Bore

These units meet the standards of UL508 and are listed under guide card #NMTR2, file #59164. These units are CSA certified under file #LR11543.

*See page 252 for specific part numbers.

Refer to Service Manual P-203.

Clutch/Brake Coupling

PCBC-500 Heavy Duty

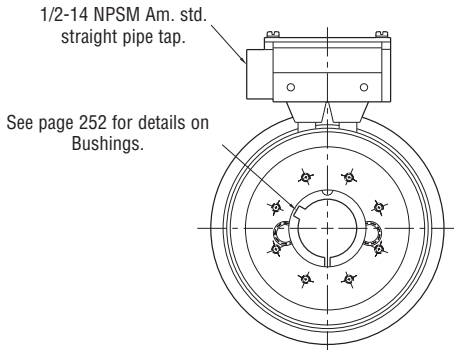

COLLECTOR RING VIEW

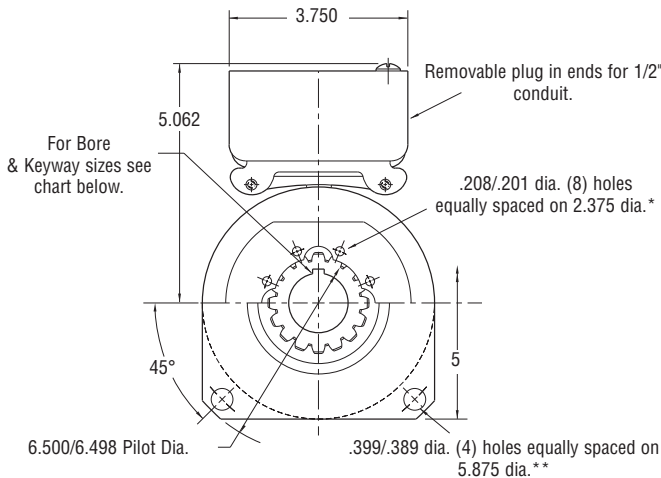

MAGNET VIEW

* Mounting holes are within .010 of true position relative to pilot diameter.
 ** Mounting holes are within .008 of true position relative to pilot diameter.

Bore and Keyway Dimensions

Armature Bore Dia.	Keyway
.751/.750 .876/.875	.187 x .093
.9385/.9375 1.001/1.000 1.126/1.125 1.251/1.250	.250 x .125

Customer Shall Maintain:

1. Squareness of brake mounting face with armature hub shaft within .006 T.I.R.
2. Concentricity of brake mounting pilot diameter with armature hub shaft within .010 T.I.R.
3. Concentricity of clutch magnet hub assembly shaft with armature hub shaft within .006 T.I.R.

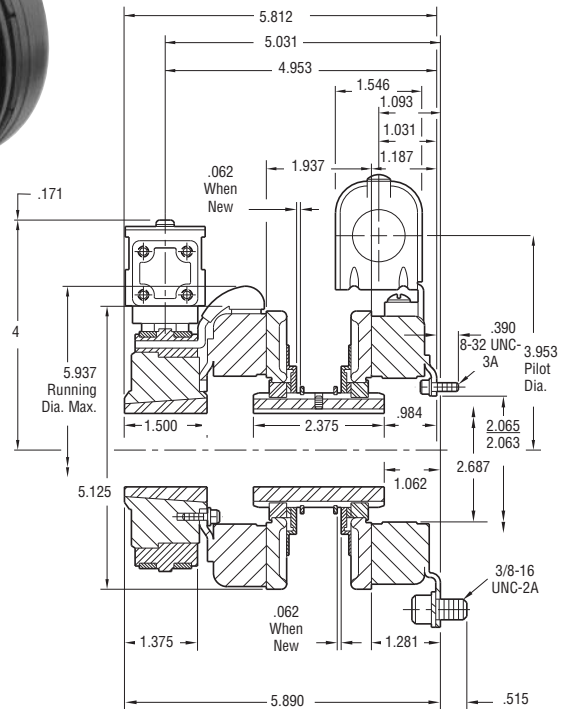

Outside Mounted Offset Backing Plate

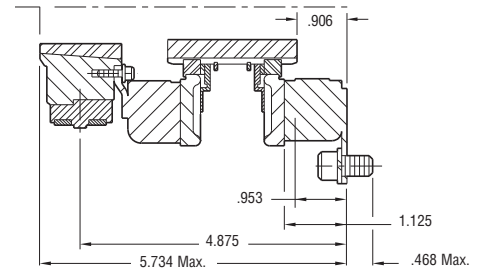

Outside Mounted Flush Backing Plate

Armature Shaft	.500 – 1.250
Magnet Shaft	.750 – 1.250
Static Torque	40 lb. ft.
Maximum Speed	5,400 rpm
Standard Voltage	D.C. 6, 24, 90

All dimensions are nominal unless otherwise noted.

Information on inertia and weights begins on page 239. Coil data is on pages 250 and 251.

Clutch/Brake Coupling

PCBC-500 Heavy Duty

Drawing I-25553

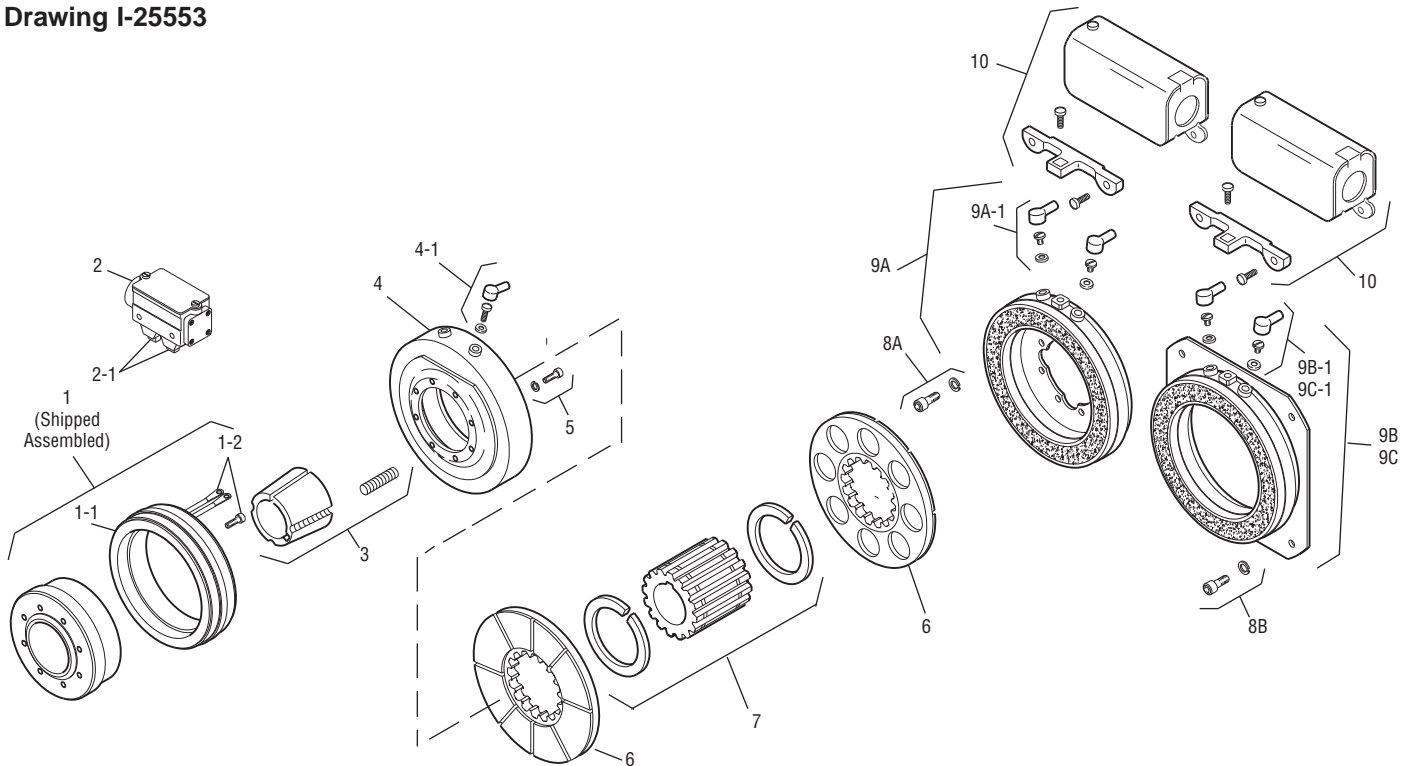

Item	Description	Part Number	Qty.
1	Magnet Hub	5300-541-001	1
1-1	Collector Ring	5300-749-001	1
1-2	Collector Ring Mounting Accessory	5300-101-002	1
2	Brushholder	5300-178-001	1
2-1	Brush	176-0001	4
3	Bushing*		1
	1/2" - 1-1/4" Bore	180-0116 to 180-0128	
4	Magnet, Clutch		1
	6 Volt	5300-631-002	
	24 Volt	5300-631-003	
	90 Volt	5300-631-005	
4-1	Terminal Accessory	5311-101-001	1
5	Mounting Accessory	5102-101-001	2
6	Armature	5230-111-002	2
7	Armature Hub		1
	Bore	Keyway	
	3/4"	3/16 x 3/32	5300-541-006
	7/8"	3/16 x 3/32	5300-541-007
	15/16"	1/4 x 1/8	5300-541-008
	1"	1/4 x 1/8	5300-541-009
	1-1/8"	1/4 x 1/8	5300-541-010
	1-1/4"	1/4 x 1/8	5300-541-011
8A	Mounting Accessory - I.M.	5102-101-001	2
8B	Mounting Accessory - O.M.	5300-101-008	1
9A	Magnet - I.M.		1
	6 Volt	5300-631-002	
	24 Volt	5300-631-003	
	90 Volt	5300-631-005	

Item	Description	Part Number	Qty.
9A-1	Terminal Accessory	5311-101-001	1
9B	Magnet - O.M. - Offset		1
	90 Volt	5300-631-014	
9B-1	Terminal Accessory	5311-101-001	1
9C	Magnet - O.M. - Flush		1
	6 Volt	5300-631-009	
	24 Volt	5300-631-010	
	90 Volt	5300-631-011	
9C-1	Terminal Accessory	5311-101-001	1
10	Conduit Box	5200-101-010	1

How to Order:

1. Specify Bore Size for Items 3 and 7.
2. Specify Voltage for Item 4 and Item 9A, 9B or 9C.
3. Specify Inside Mounted for Item 9A and Outside Mounted (Offset) for Item 9B or Outside Mounted (Flush) for Item 9C.
4. Specify Inside Mount for Item 8A or Outside Mount for Item 8B.
5. See Controls Section.

Example:

PCBC-500 Clutch Brake Coupling per I-25553 - 90 Volt, Outside Mounted Flush, 1" Bore

These units meet the standards of UL508 and are listed under guide card #NMTR2, file #59164. These units are CSA certified under file #LR11543.

*See page 252 for specific part numbers.

Refer to Service Manual P-203.

Clutch/Brake Coupling

PCBC-825

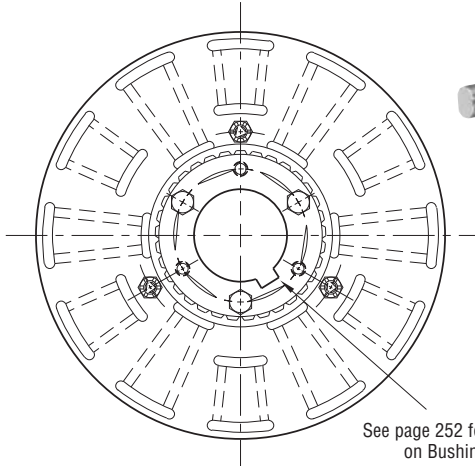

ARMATURE VIEW

See page 252 for details on Bushings.

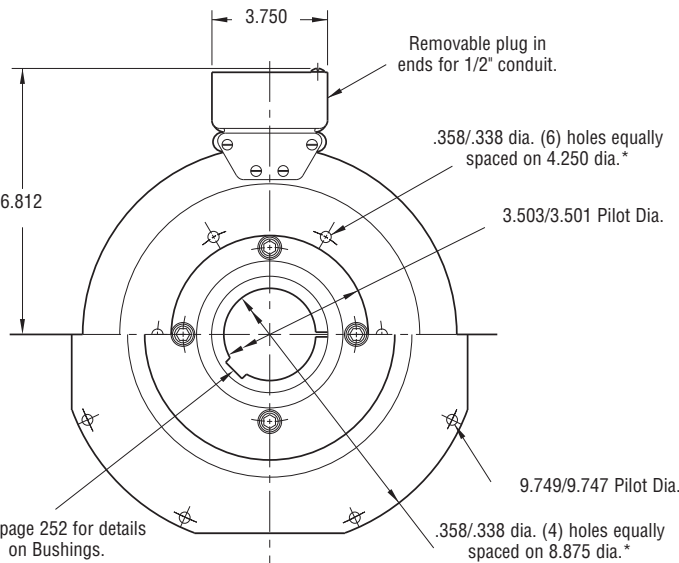
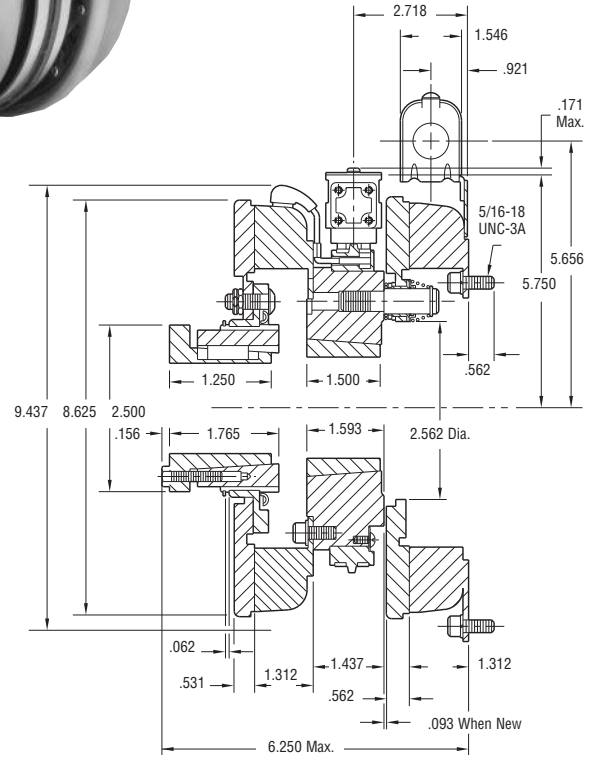

**MAGNET VIEW
(Inside & Outside Mounted)**

See page 252 for details on Bushings.

* Mounting holes are within .010 of true position relative to pilot diameter.

Customer Shall Maintain:

1. Armature mounting shaft concentric with magnet mounting shaft within .006 T.I.R.
2. Squareness of brake magnet mounting face with magnet mounting shaft within .006 T.I.R.
3. Concentricity of brake magnet mounting pilot diameter with magnet mounting shaft within .010 T.I.R.
4. Angular alignment of shafts within 1/2 degree.

Armature Shaft	.500 – 1.500
Magnet Shaft	.500 – 1.625
Static Torque	125 lb.ft.
Maximum Speed	4,000 rpm
Standard Voltage	D.C. 6, 24, 90

All dimensions are nominal unless otherwise noted.

Information on inertia and weights begins on page 239. Coil data is on pages 250 and 251.



Drawing I-25570

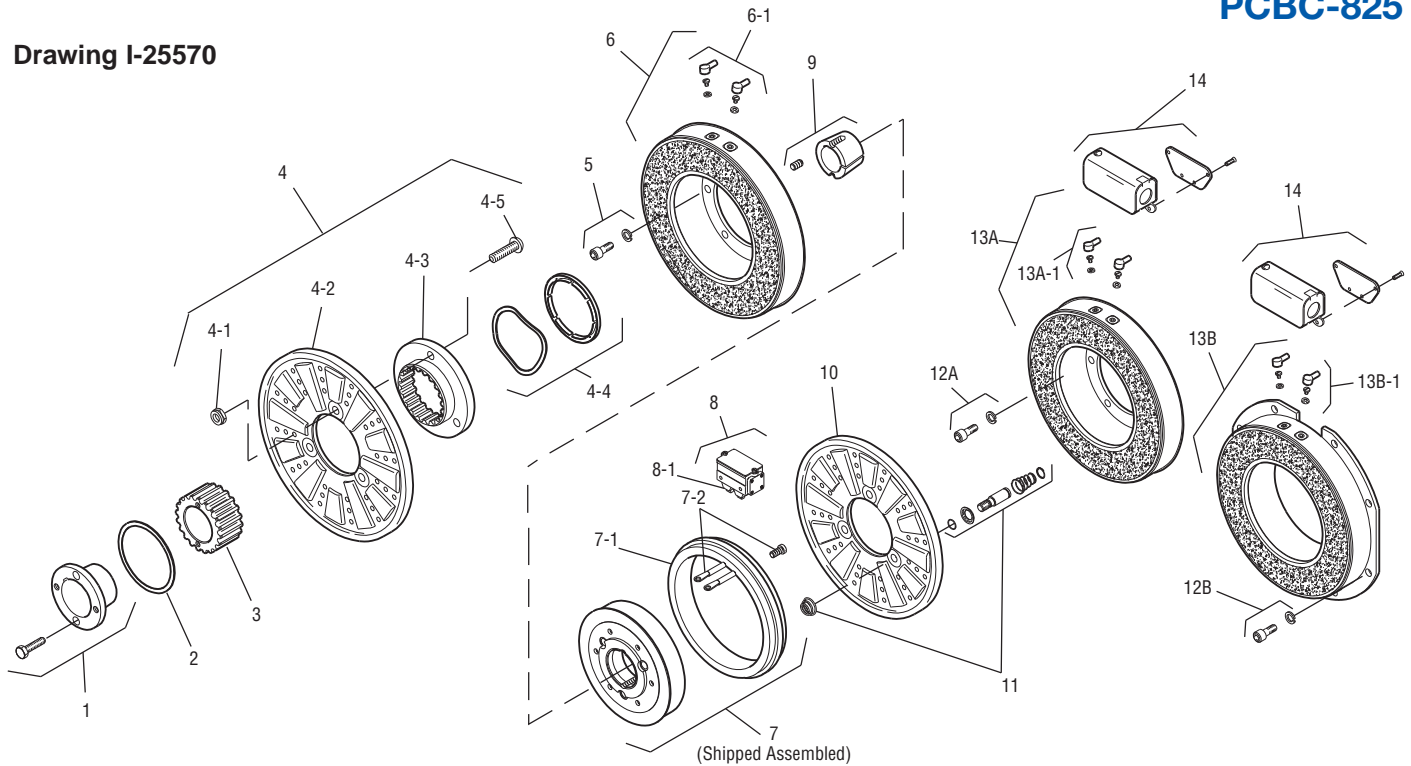

Item	Description	Part Number	Qty.
1	Bushing* - 1/2" to 1-1/2" Bore	180-0002 to 180-0018	1
2	Retainer Ring	748-0006	1
3	Splined Hub	540-0057	1
4	Armature & Splined Adapter	5321-111-001	1
4-1	Locknut	661-0004	3
4-2	Armature	5321-111-022	1
4-3	Splined Adapter	104-0008	1
4-4	Autogap Accessory	5321-101-006	1
4-5	Screw	797-0272	3
5	Mounting Accessory	5321-101-001	1
6	Magnet		1
	6 Volt	5301-631-002	
	24 Volt	5301-631-004	
	90 Volt	5301-631-005	
6-1	Terminal Accessory	5311-101-001	1
7	Magnet Hub		1
	Left Hand (shown)	5301-541-001	
	Right Hand	5301-541-002	
7-1	Collector Ring	5301-749-001	1
7-2	Collector Ring Accessory	5301-101-002	1
8	Brushholder	5300-178-001	1
8-1	Brush	176-0001	4
9	Bushing* - 1/2" to 1-5/8" Bore	180-0131 to 180-0149	1
10	Armature	5301-111-018	1
11	Autogap Accessory	5201-101-008	3
12A	Mounting Accessory - I.M.	5321-101-001	1
12B	Mounting Accessory - O.M.	5321-101-002	1

Item	Description	Part Number	Qty.
13A	Magnet - Inside Mounted		1
	6 Volt	5311-631-002	
	24 Volt	5311-631-003	
	90 Volt	5311-631-004	
13A-1	Terminal Accessory	5311-101-001	1
13B	Magnet - Outside Mounted		1
	6 Volt	5311-631-007	
	24 Volt	5311-631-009	
	90 Volt	5311-631-008	
13B-1	Terminal Accessory	5311-101-001	1
14	Conduit Box	5200-101-011	1

How to Order:

1. Specify Bore Size for Items 1 and 9.
2. Specify Voltage for Items 6 and 13.
3. Specify left hand or right hand hub for Item 7. Bushing enters from magnet side for L.H. hub and from hub side for R.H.
4. Specify Inside Mounted for Items 12A and 13A or Outside Mounted for Items 12B and 13B.
5. See Controls Section.

Example:

PCBC-825 Clutch Brake Coupling per I-25570 - 90 Volt, Inside Mounted, Left Hand hub, 1" Bore, (Items 1 and 9)

These units meet the standards of UL508 and are listed under guide card #NMTR2, file #59164. These units are CSA certified under file #LR11543.

*See page 252 for specific part numbers.

Refer to Service Manual P-205.

Clutch/Brake Coupling

PCBC-1000

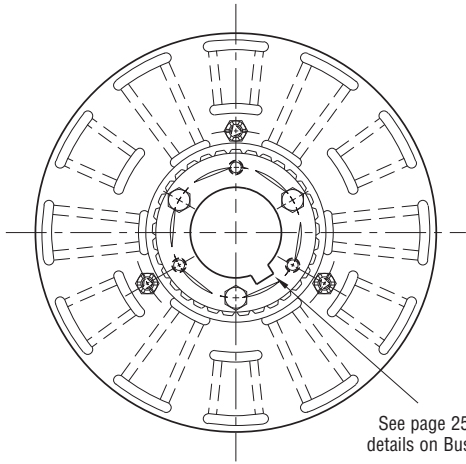

ARMATURE VIEW

See page 252 for details on Bushings.

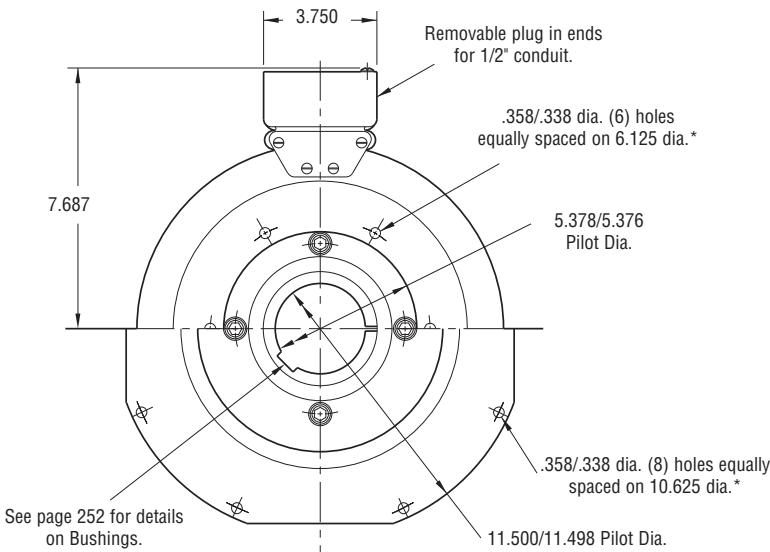

**MAGNET VIEW
(Inside & Outside Mounted)**

Customer Shall Maintain:

1. Armature mounting shaft concentric with magnet mounting shaft within .006 T.I.R.
2. Squareness of brake magnet mounting face with magnet mounting shaft within .006 T.I.R.
3. Concentricity of brake magnet mounting pilot diameter with magnet mounting shaft within .010 T.I.R.
4. Angular alignment of shafts within 1/2 degree.

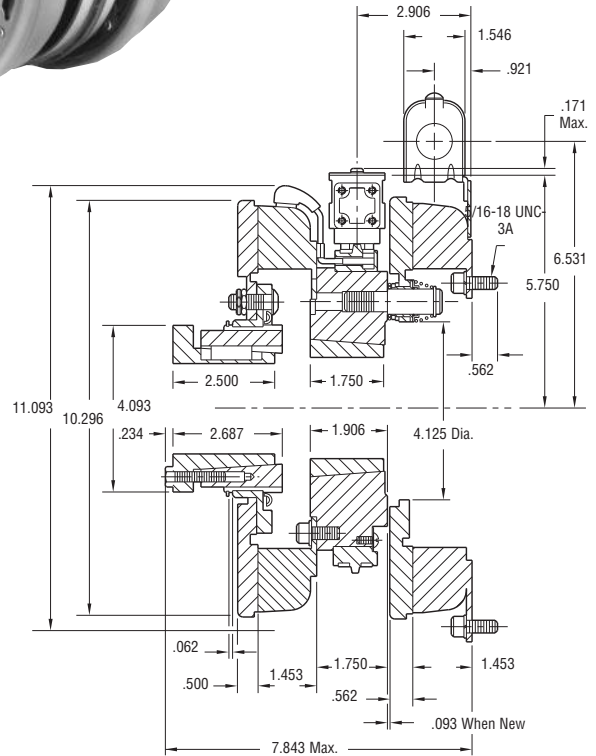

* Mounting holes are within .010 of true position relative to pilot diameter.

Armature Shaft	.750 – 2.687
Magnetic Shaft	.500 – 2.500
Static Torque	240 lb.ft.
Maximum Speed	3,600 rpm
Standard Voltage	D.C. 6, 24, 90

All dimensions are nominal unless otherwise noted.

Information on inertia and weights begins on page 239. Coil data is on pages 250 and 251.



Drawing I-25590

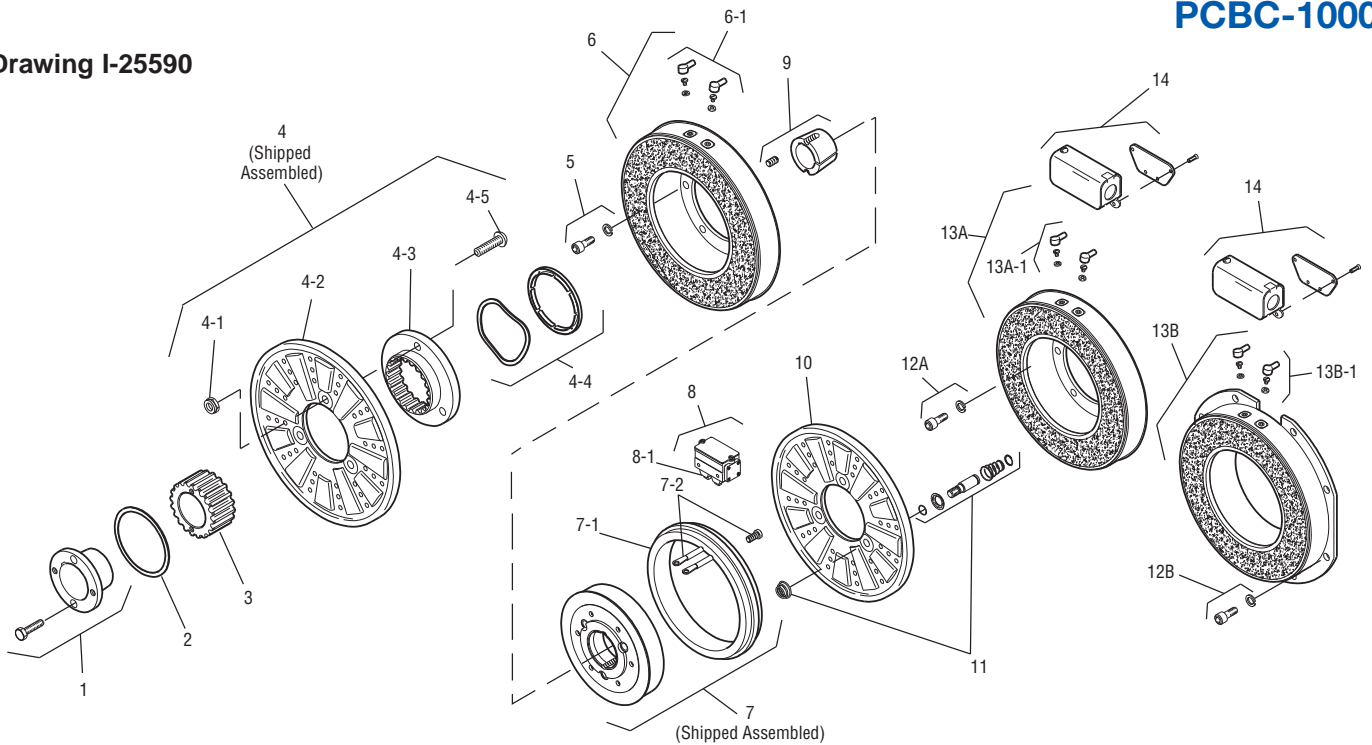

Item	Description	Part Number	Qty.
1	Bushing* 3/4" to 2-11/16" Bore	180-0026 to 180-0057	1
2	Retainer Ring	748-0007	1
3	Splined Hub	540-0062	1
4	Armature & Splined Adapter	5322-111-002	1
4-1	Locknut	661-0004	3
4-2	Armature	5322-111-036	1
4-3	Splined Adapter	104-0009	1
4-4	Autogap Accessory	5322-101-004	1
4-5	Screw	797-0272	3
5	Mounting Accessory	5321-101-001	1
6	Magnet		1
	6 Volt	5302-631-003	
	24 Volt	5302-631-014	
	90 Volt	5302-631-005	
6-1	Terminal Accessory	5311-101-001	1
7	Magnet Hub		1
	Left Hand (shown)	5302-541-001	
	Right Hand	5302-541-002	
7-1	Collector Ring	5301-749-001	1
7-2	Collector Ring Accessory	5302-101-002	1
8	Brushholder	5300-178-001	1
8-1	Brush	176-0001	4
9	Bushing*		1
	1/2" to 2-1/2" Bore	180-0185 to 180-0217	
10	Armature	5302-111-013	1
11	Autogap Accessory	5201-101-008	3
12A	Mounting Accessory - I.M.	5321-101-001	1
12B	Mounting Accessory - O.M.	5321-101-002	2

Item	Description	Part Number	Qty.
13A	Magnet - Inside Mounted		1
	6 Volt	5312-631-004	
	24 Volt	5312-631-005	
	90 Volt	5312-631-006	
13A-1	Terminal Accessory	5311-101-001	1
13B	Magnet - Outside Mounted		1
	6 Volt	5312-631-011	
	24 Volt	5312-631-013	
	90 Volt	5312-631-012	
13B-1	Terminal Accessory	5311-101-001	1
14	Conduit Box	5200-101-011	1

How to Order:

1. Specify Bore Size for Items 1 and 9.
2. Specify Voltage for Items 6 and 13.
3. Specify left hand or right hand hub for Item 7. Bushing enters from magnet side for L.H. hub and from hub side for R.H.
4. Specify Inside Mounted for Items 12A and 13A or Outside Mounted for Items 12B and 13B.
5. See Controls Section.

Example:

PCBC-1000 Clutch Brake Coupling per I-25590 - 90 Volt, Inside Mounted, Left Hand hub, 1-1/2" Bore, (Items 1 and 9)

These units meet the standards of UL508 and are listed under guide card #NMTR2, file #59164. These units are CSA certified under file #LR11543.

*See page 252 for specific part numbers.

Refer to Service Manual P-205.

Clutch/Brake Coupling

PCBC-1225/1000

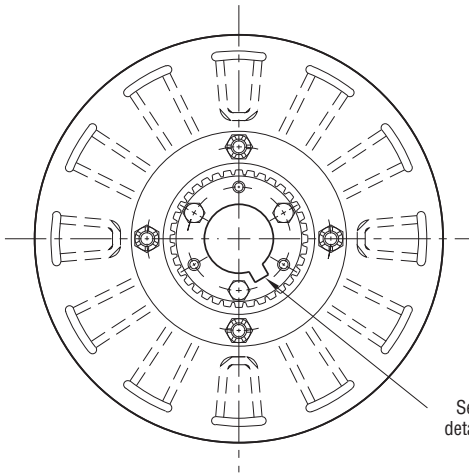

ARMATURE VIEW

See page 252 for details on Bushings.

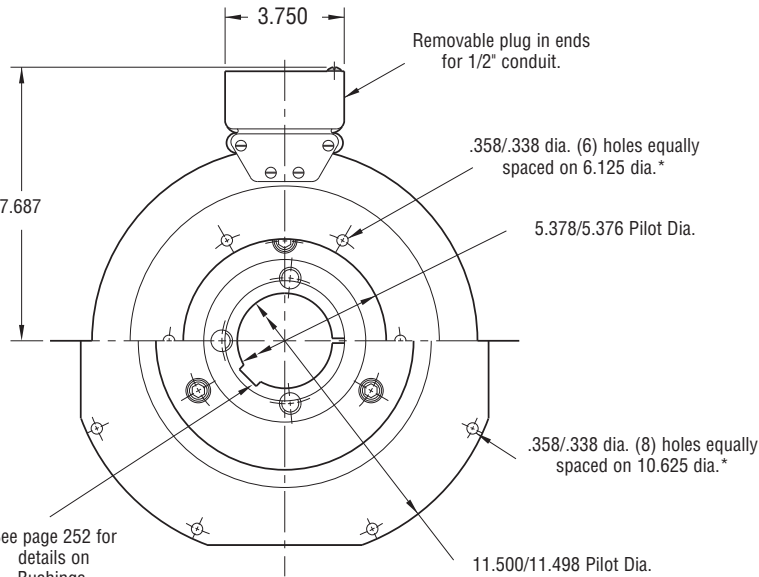

See page 252 for details on Bushings.

**MAGNET VIEW
(Inside & Outside Mounted)**

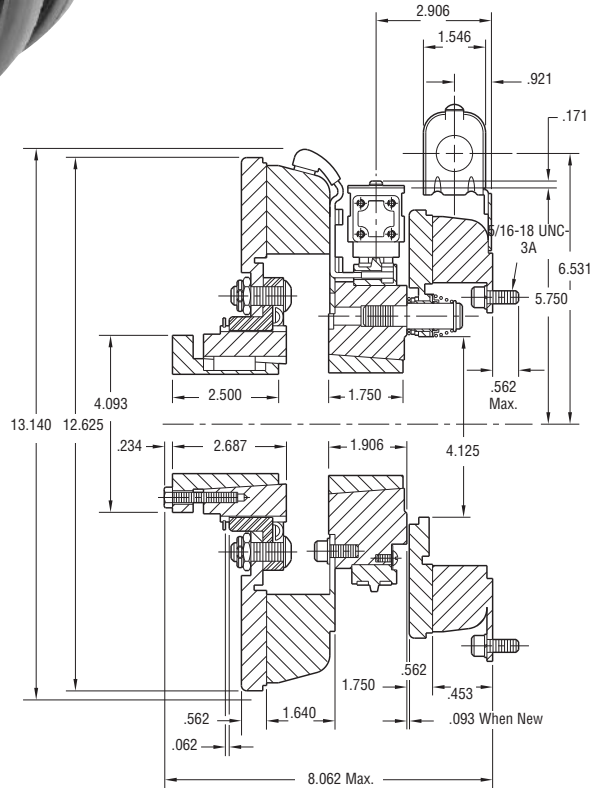

* Mounting holes are within .010 of true position relative to pilot diameter.

Customer Shall Maintain:

1. Armature mounting shaft concentric with magnet mounting shaft within .006 T.I.R.
2. Squareness of brake magnet mounting face with magnet mounting shaft within .006 T.I.R.
3. Concentricity of brake magnet mounting pilot diameter with magnet mounting shaft within .010 T.I.R.

Armature Shaft	.750 – 2.687
Magnet Shaft	.500 – 2.500
Static Torque Clutch	465 lb.ft.
Static Torque Brake	240 lb.ft.
Maximum Speed	3,000 rpm
Standard Voltage	D.C. 6, 90

All dimensions are nominal unless otherwise noted.

Information on inertia and weights begins on page 239. Coil data is on pages 250 and 251.



Drawing I-25613

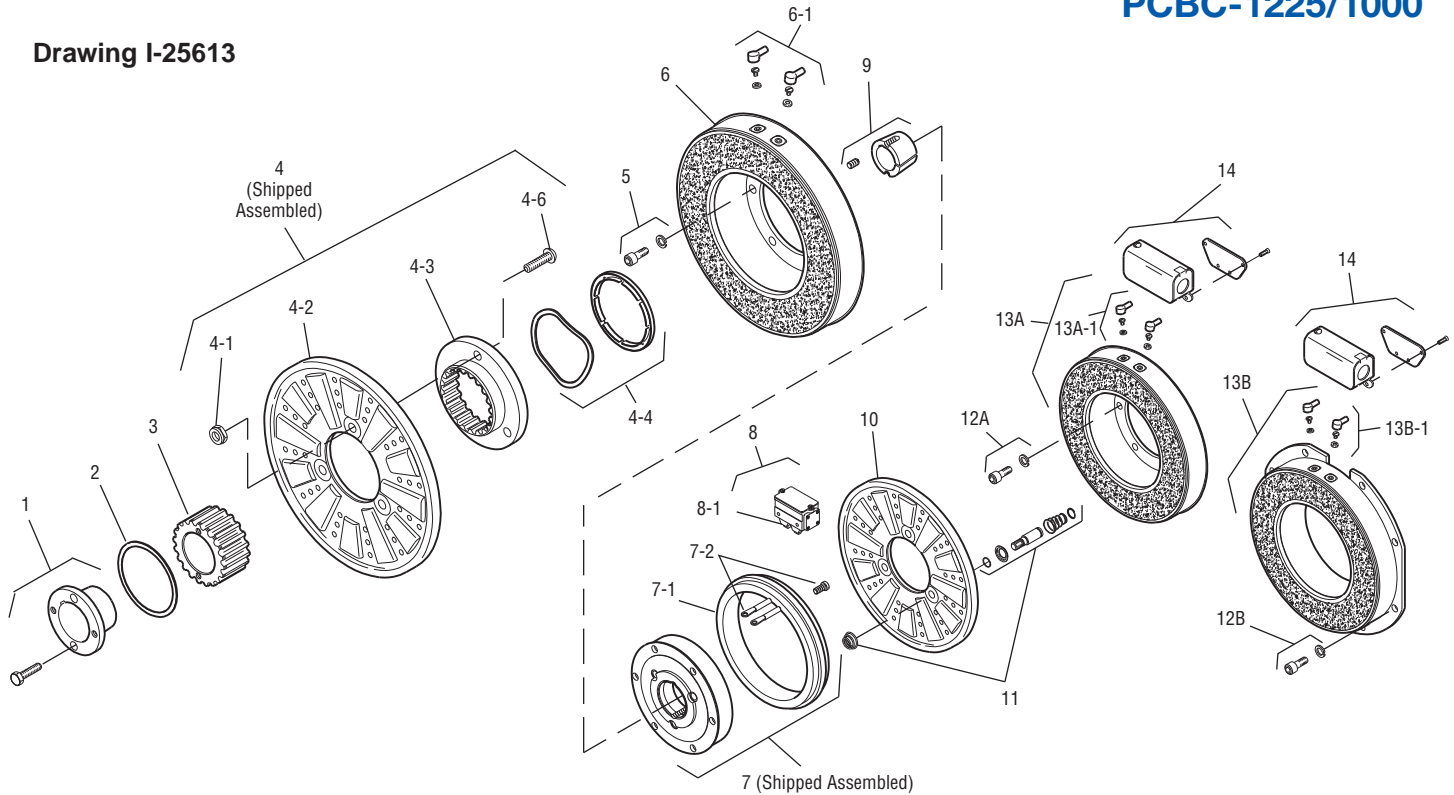

Item	Description	Part Number	Qty.
1	Bushing*		1
	3/4" to 2-11/16" Bore	180-0026 to 180-0057	
2	Retainer Ring	748-0005	1
3	Splined Hub	540-0064	1
4	Armature & Splined Adapter	5323-111-001	1
4-1	Locknut	661-0005	4
4-2	Armature	5323-111-034	1
4-3	Splined Adapter	104-0010	1
4-4	Autogap Accessory	5323-101-002	1
4-6	Screw	797-0281	4
5	Mounting Accessory	5321-101-001	1
6	Magnet		1
	6 Volt	5333-631-008	
	90 Volt	5333-631-009	
	†90 Volt LK Facing	5333-631-013	
6-1	Terminal Accessory	5311-101-001	1
7	Magnet Hub		1
	Left Hand (shown)	5302-541-004	
	Right Hand	5302-541-005	
7-1	Collector Ring	5301-749-001	1
7-2	Collector Ring Accessory	5303-101-004	1
8	Brushholder	5300-178-001	1
8-1	Brush	176-0001	4
9	Bushing*		1
	1/2" to 2-1/2" Bore	180-0185 to 180-0217	
10	Armature	5302-111-013	1
11	Autogap Accessory	5201-101-008	3
12A	Mounting Accessory - I.M.	5321-101-001	1

Item	Description	Part Number	Qty.
12B	Mounting Accessory - O.M.	5321-101-002	2
13A	Magnet - Inside Mounted		1
	6 Volt	5312-631-004	
	90 Volt	5312-631-006	
13A-1	Terminal Accessory	5311-101-001	1
13B	Magnet - Outside Mounted		1
	6 Volt	5312-631-011	
	90 Volt	5312-631-012	
13B-1	Terminal Accessory	5311-101-001	1
14	Conduit Box	5200-101-011	1

How to Order:

1. Specify Bore Size for Item 1 and 9.
2. Specify Voltage for Item 6 and Item 13A or 13B.
3. Specify left hand or right hand hub for Item 7. Bushing enters from magnet side for L.H. hub and from hub side for R.H.
4. Specify Inside Mounted for Items 12A and 13A or Outside Mounted for Items 12B and 13B.
5. See Controls Section.

Example:

PCBC-1225/1000 Clutch Brake Coupling per I-25613 - 90 Volt, Inside Mounted, Left Hand hub, 1-3/4" Bore, (Items 1 and 9).

These units meet standards set forth in UL508 and are listed under guide card #NMTR2, file #59164. These units are CSA certified under file #LR11543.

*See page 252 for specific part numbers.

Refer to Service Manual P-214.

†Optional LK facing available. For more information, see page 232.

Clutch/Brake Coupling

PCBC-1225

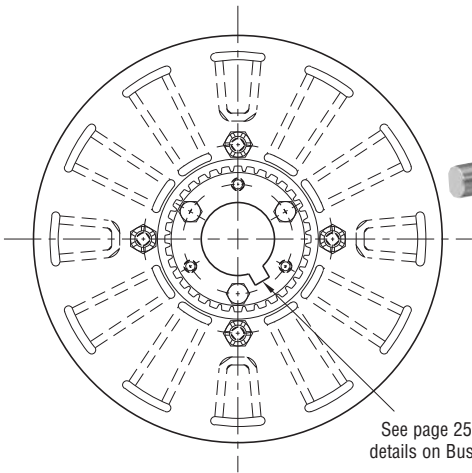
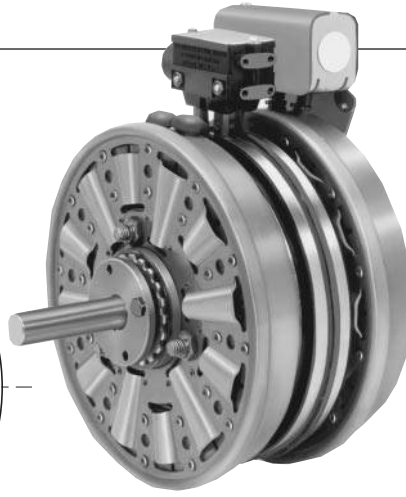

See page 252 for details on Bushings.

ARMATURE VIEW

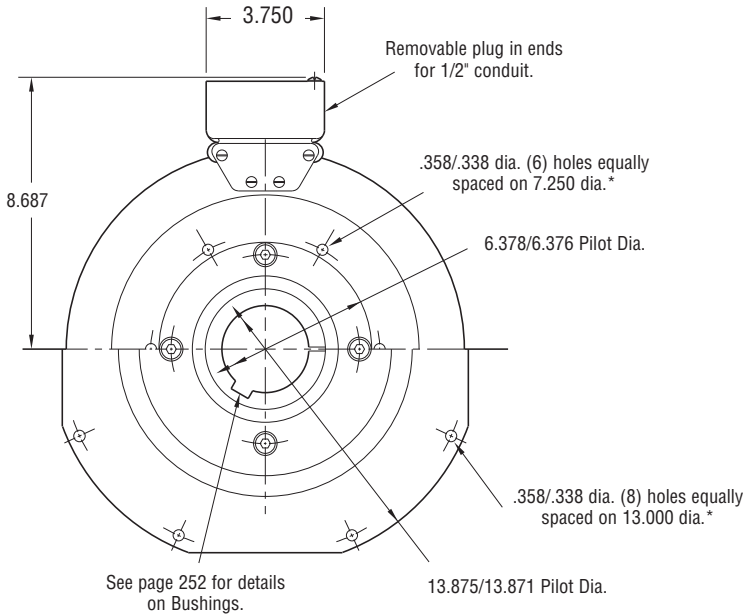

MAGNET VIEW (Inside & Outside Mounted)

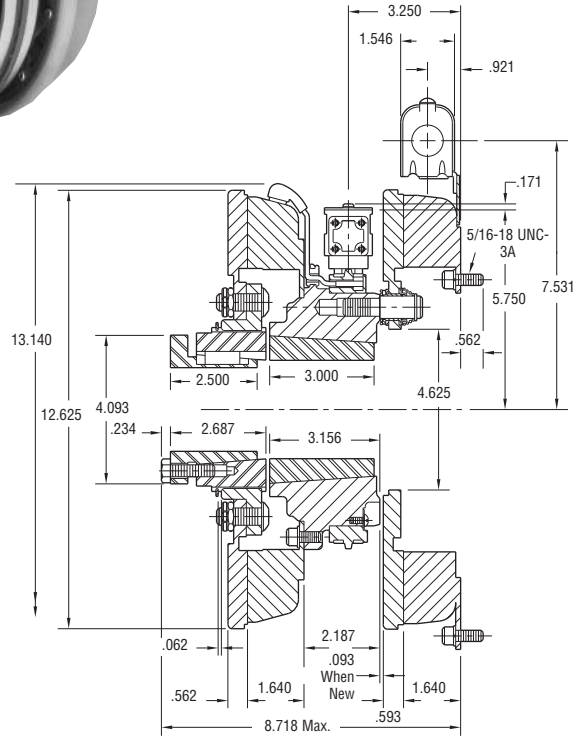

* Mounting holes are within .010 of true position relative to pilot diameter.

Customer Shall Maintain:

1. Armature mounting shaft concentric with magnet mounting shaft within .006 T.I.R.
2. Squareness of brake magnet mounting face with magnet mounting shaft within .006 T.I.R.
3. Concentricity of brake magnet mounting pilot diameter with magnet mounting shaft within .010 T.I.R.
4. Angular alignment of shafts within 1/2 degree.

Armature Shaft	.750 – 2.687
Magnet Shaft	.937 – 3.000
Static Torque	465 lb.ft.
Maximum Speed	3,000 rpm
Standard Voltage	D.C. 6, 24, 90

All dimensions are nominal unless otherwise noted.

Information on inertia and weights begins on page 239. Coil data is on pages 250 and 251.



Drawing I-25612

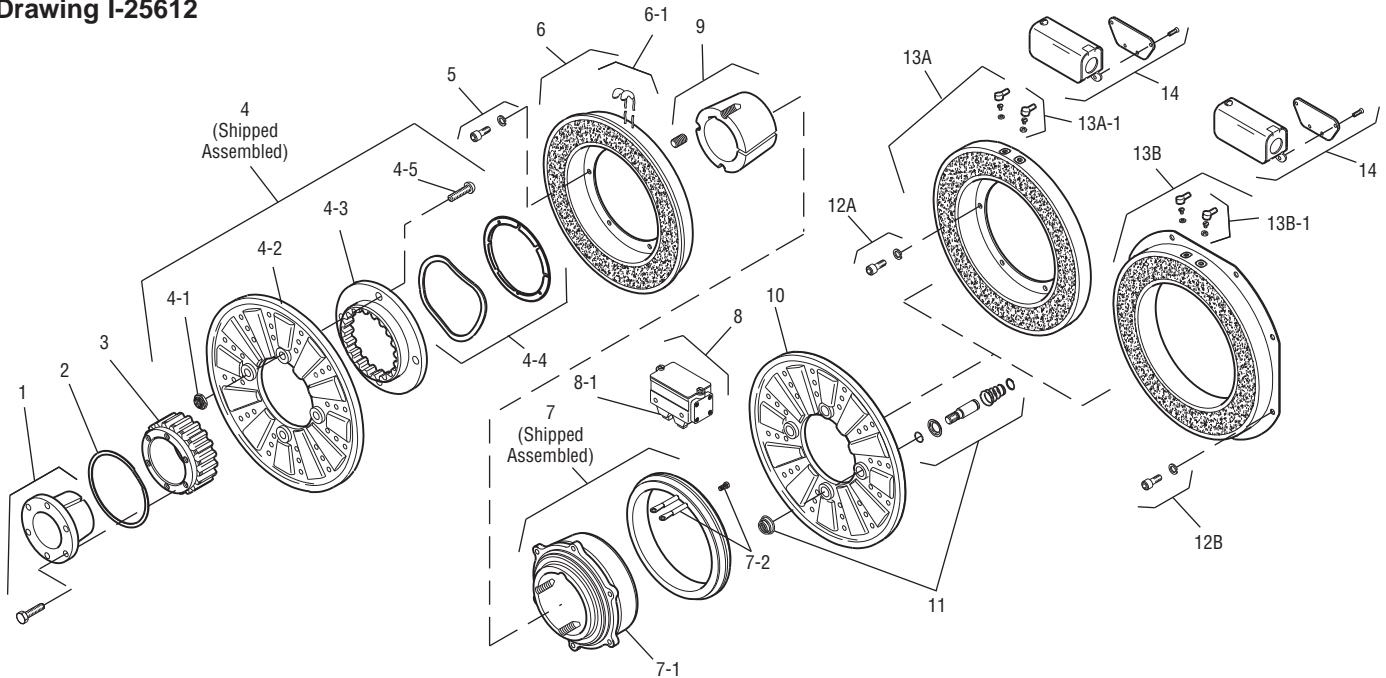

Item	Description	Part Number	Qty.
1	Bushing*		1
	3/4" to 2-11/16" Bore	180-0026 to 180-0057	
2	Retainer Ring	748-0005	1
3	Splined hub	540-0064	1
4	Armature & Splined Adapter	5323-111-001	1
4-1	Locknut	661-0005	4
4-2	Armature	5323-111-034	1
4-3	Splined Adapter	104-0010	1
4-4	Autogap Accessory	5323-101-002	1
4-5	Screw	797-0281	4
5	Mounting Accessory	5321-101-001	1
6	Magnet		1
	6 Volt	5303-631-005	
	24 Volt	5303-631-007	
	90 Volt	5303-631-008	
6-1	Terminal Accessory	5311-101-001	1
7	Magnet Hub		1
	Left Hand (shown)	5303-541-001	
	Right Hand	5303-541-002	
7-1	Collector Ring	5301-749-001	1
7-2	Collector Ring Assembly	5303-101-004	1
8	Brushholder	5300-178-001	1
8-1	Brush	176-0001	4
9	Bushing*		1
	15/16" to 3" Bore	180-0262 to 180-0295	
10	Armature	5303-111-009	1
11	Autogap Accessory	5201-101-008	4
12A	Mounting Accessory - I.M.	5321-101-001	1
12B	Mounting Accessory - O.M.	5321-101-002	2

Item	Description	Part Number	Qty.
13A	Magnet - Inside Mounted		1
	6 Volt	5313-631-005	
	24 Volt	5313-631-006	
	90 Volt	5313-631-007	
13A-1	Terminal Accessory	5311-101-001	1
13B	Magnet - Outside Mounted		1
	6 Volt	5313-631-010	
	24 Volt	5313-631-012	
	90 Volt	5313-631-011	
13B-1	Terminal Accessory	5311-101-001	1
14	Conduit Box	5200-101-010	1

How to Order:

1. Specify Bore Size for Items 1 and 9.
2. Specify Voltage for Items 6 and 13.
3. Specify left hand or right hand hub for Item 7. Bushing enters from magnet side for L.H. hub and from hub side for R.H.
4. Specify Inside Mounted for Items 12A and 13A or Outside Mounted for Items 12B and 13B.
5. See Controls Section.

Example:

PCBC-1225 Clutch Brake Coupling per I-25612 - 90 Volt, Inside Mounted Left Hand hub, 1-3/4" Bore (Items 1 and 9)

These units meet the standards of UL508 and are listed under guide card #NMTR2, file #59164. These units are CSA certified under file #LR11543.

*See page 252 for specific part numbers.

Refer to Service Manual P-205.

Clutch/Brake Coupling

PCBC-1525/1225

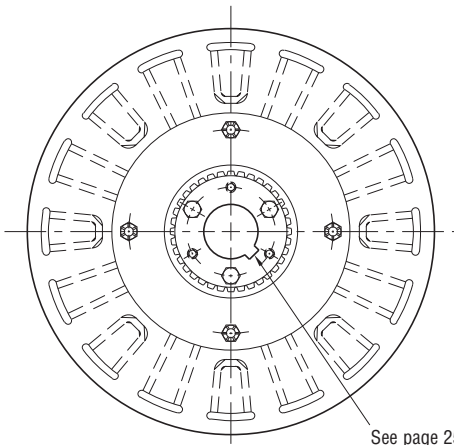
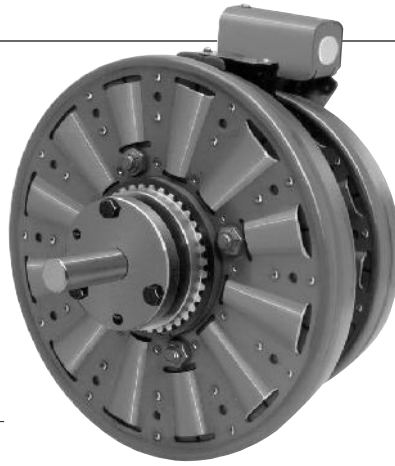

ARMATURE VIEW

See page 252 for details on Bushings.

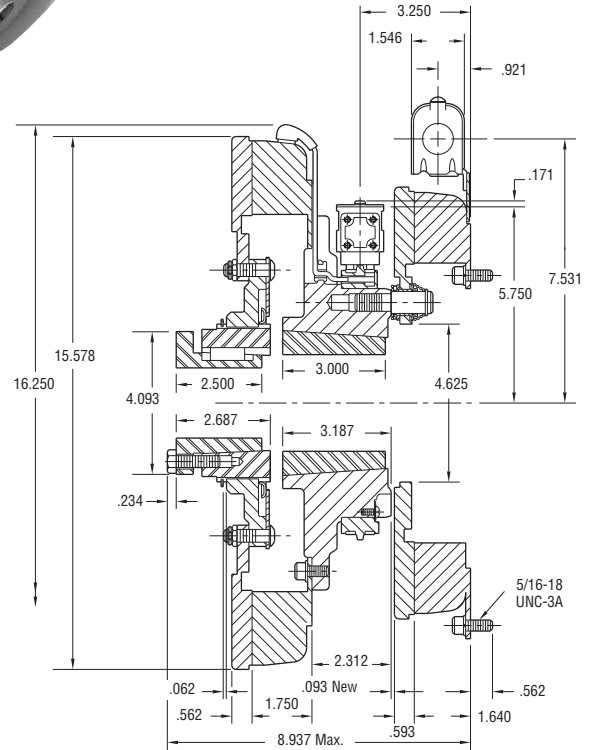

* Mounting holes are within .010 of true position relative to pilot diameter.

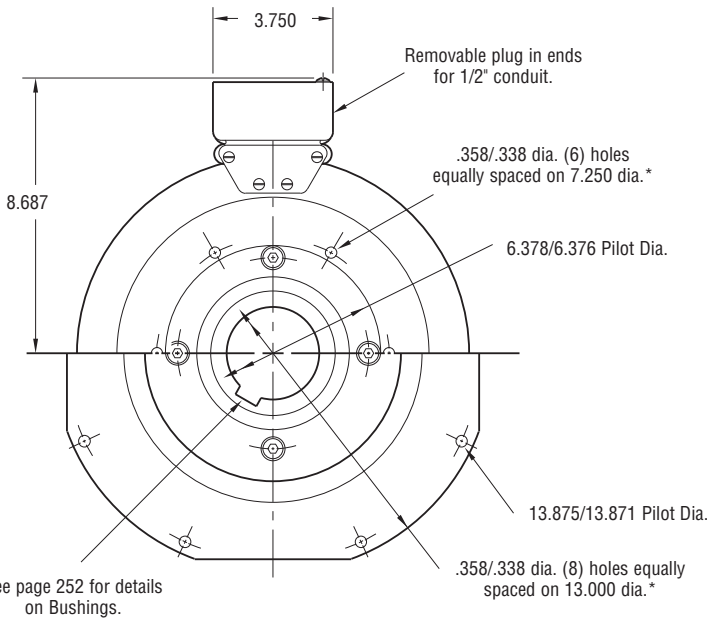

MAGNET VIEW
(Inside & Outside Mounted)

See page 252 for details on Bushings.

Customer Shall Maintain:

1. Armature mounting shaft concentric with magnet mounting shaft within .006 T.I.R.
2. Squareness of brake magnet mounting face with magnet mounting shaft within .006 T.I.R.
3. Concentricity of brake magnet mounting pilot diameter with magnet mounting shaft within .010 T.I.R.

Armature Shaft	.750 – 2.687
Magnet Shaft	.937 – 3.000
Static Torque Clutch	700 lb.ft.
Static Torque Brake	465 lb.ft.
Maximum Speed	2,000 rpm
Standard Voltage	D.C. 6, 24, 90

All dimensions are nominal unless otherwise noted.

Information on inertia and weights begins on page 239. Coil data is on pages 250 and 251.



Drawing I-25637

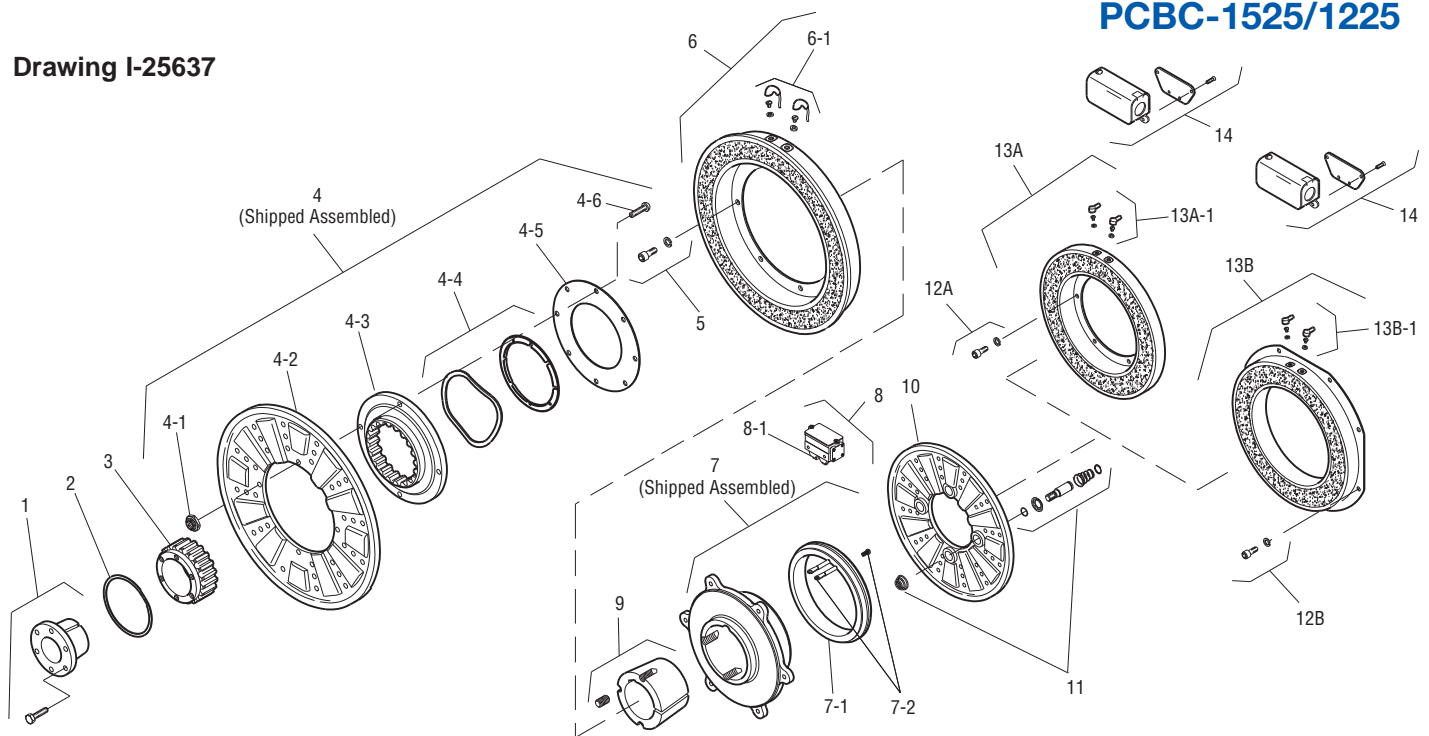

Item	Description	Part Number	Qty.
1	Bushing*		1
	3/4" to 2-11/16" Bore	180-0026 to 180-0057	
2	Retainer Ring	748-0005	1
3	Splined Hub	540-0064	1
4	Armature & Splined Adapter	5324-111-001	1
4-1	Locknut	661-0004	8
4-2	Armature	5324-111-034	1
4-3	Splined Adapter	104-0011	1
4-4	Autogap Accessory	5323-101-002	1
4-5	Retainer Plate	686-0003	1
4-6	Screw	797-0272	8
5	Mounting Accessory	5321-101-001	2
6	Magnet		1
	6 Volt	5304-631-009	
	24 Volt	5304-631-011	
	90 Volt	5304-631-010	
6-1	Terminal Accessory	5311-101-001	1
7	Magnet Hub		1
	Left Hand (shown)	5304-541-001	
	Right Hand	5304-541-002	
7-1	Collector Ring	5301-749-001	1
7-2	Collector Ring Accessory	5304-101-004	1
8	Brushholder	5300-178-001	1
8-1	Brush	176-0001	4
9	Bushing*		1
	15/16" to 3" Bore	180-0262 to 180-0295	
10	Armature	5303-111-009	1
11	Autogap Accessory	5201-101-008	4
12A	Mounting Accessory - I.M.	5321-101-001	1

Item	Description	Part Number	Qty.
12B	Mounting Accessory - O.M.	5321-101-002	2
13A	Magnet - Inside Mounted		1
	6 Volt	5313-631-005	
	24 Volt	5313-631-006	
	90 Volt	5313-631-007	
13A-1	Terminal Accessory	5311-101-001	1
13B	Magnet - Outside Mounted		1
	6 Volt	5313-631-010	
	24 Volt	5313-631-012	
	90 Volt	5313-631-011	
13B-1	Terminal Accessory	5311-101-001	1
14	Conduit Box	5200-101-010	1

How to Order:

1. Specify Bore Size for Items 1 and 9.
2. Specify Voltage for Item 6 and 13A or 13B.
3. Specify left hand or right hand hub for Item 7. Bushing enters from magnet side for L.H. hub and from hub side for R.H.
4. Specify Inside Mounted for Items 12A and 13A or Outside Mounted for Items 12B and 13B.
5. See Controls Section.

Example:

PCBC-1525/1225 Clutch Brake Coupling per I-25637 - 90 Volt, Inside Mounted, Left Hand hub, 2" Bore (Items 1 and 9)

These units meet the standards of UL508 and are listed under guide card #NMTR2, file #59164. These units are CSA certified under file #LR11543.

*See page 252 for specific part numbers.

Refer to Service Manual P-214.