

Long Life, High Performance Design

The Super CB Series Clutch/Brakes function in the same manner as the standard CB Series. The major advantage of the Super CB Series is extraordinary long life, up to five times longer than a standard unit. This makes the Super CB Series the ideal choice for applications involving high cycle rates and continuous heavy-duty operation.

Super CB Series design features

The standard CB Series and SCB Series units both employ three primary hubs that are oil impregnated; the input hub, the brake hub and an internal hub pinned to the output shaft. On standard units, the oil lubricates the bearing surfaces of the input and brake hub, while the Super CB Series uses needle bearings in the input and brake hubs to increase the radial bearing load capacity. Both types require oil in the hubs to lubricate the springs. The Super CB Series units also feature hardened steel wear rings on the primary hubs at the crossover point of the clutch, brake and shaft hubs to further increase life. The control collar assemblies are glass reinforced nylon, strengthened by steel or aluminum inserts. The actuators are Delrin AF on all models.

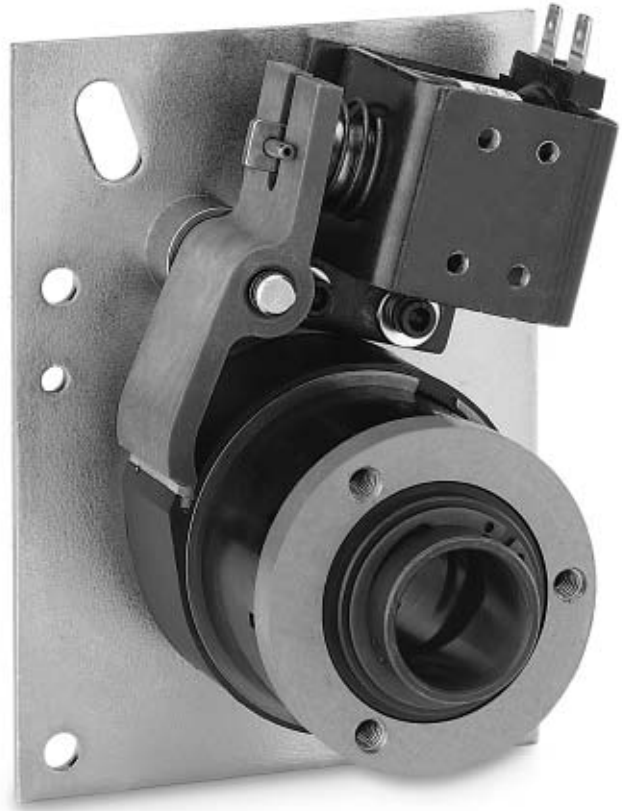

Features

- Increased life-up to five times longer than standard models
- Stop Position Accuracy $\pm 1/2^\circ$
- Adjustable Output Stop Positions
- Standard Features
 - CW or CCW Rotation
 - Hub Input – Shaft Output
 - Anti-Ovrrun Output does not ovrrun Input
 - Anti-Back Output does not Backup
- 1, 2 and 4 stop collars for 360°, 180°, and 90° output increments standard
 - Special multi-stop collars also available (up to 24 stops)
- 115 VAC and 24 VDC Solenoids Standard
 - Other Voltages Available
- Dimensionally Interchangeable With Competitive Units
- 3 Standard Models
 - SCB-5
 - SCB-6
 - SCB-8
- High torque in small package.
- Actuating solenoid is AC or DC operated.
- Brake engages automatically when de-clutched.
- Maintenance-free self-lubricating hubs are 18% oil by volume.
- Hardened thrust washers on input and brake end.
- Sintered metal hub offers easy machining for custom drive attachments.
- Hardened and ground shaft.
- Hub mounting holes for simple pulley or sprocket mounting.
- Hardened crossover points on input, output and brake hubs provide increased life.
- Steel tip insert on control cam collar.
- Single or multi-stop collars available.

Distribuidor Autorizado e Importador - Arten Freios e Embreagens Ltda.

Fone: (11) 5594-8333 • Fax (11) 5589-2422 - arten@arten.com.br • www.arten.com.br

Super CB Series Clutch/Brakes

Specifications	SCB-5	SCB-6	SCB-8
Static Torque	250 lb.in. (28.25 N-m)	500 lb.in. (56.5 N-m)	2,500 lb.in. (282.5 N-m)
Maximum anti-overflow holding capability	125 lb.in. (14.125 N-m)	300 lb.in. (33.9 N-m)	600 lb.in. (67.8 N-m)
Maximum anti-back holding capability	125 lb.in. (14.125 N-m)	300 lb.in. (33.9 N-m)	600 lb.in. (67.8 N-m)
Inertia, rotating parts	.236 lb.in. ²	1.718 lb.in. ²	12.840 lb.in. ²
Maximum radial bearing load at maximum speed	35 lbs.	65 lbs.	300 lbs.
Maximum operating speed	750 RPM	500 RPM	300 RPM
Response time, voltage on at full speed	27 MS	45 MS	50 MS
Weight	3 lbs.	7 lbs.	15 lbs.

See page 32 for Minimum Inertia Requirements.

See page 8 for Mounting Instructions.

Control Collars

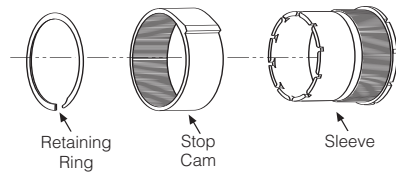

These clutch/brakes offer unique splined stop collars which can be adjusted radially in fine increments. This feature allows the user to reposition the output to comply with specified shaft and keyway placements. Standard stop collar positioning increments are shown below for all models:

SCB-5	1.8° Adjustable
SCB-6	1.8° Adjustable
SCB-8	1.6° Adjustable

Optional Multiple Stop Collars



A one, two or four stop collar is standard on SCB Series clutch/brakes.

A variety of stop collar configurations, up to 24* stops maximum, are available. Consult Warner Electric Technical Support at 800-825-9050 for complete information.

*Note: 4 stop maximum with steel tip cam.

Basic Selection

See pages 6–7 for basic product selection guidelines.

For complete Application Engineering information see pages 32–34.

How to Order

Order by part number (see chart on dimensions page) or specify as follows.

Specify:

- Series Super CB
English
Metric
- Size: SCB-5, SCB-6, SCB-8
- Direction of rotation:
CW Clockwise
CCW Counterclockwise
- Coil voltage:
115 AC or 24 DC are standard
12 DC or 90 DC are options
- Bore size:
SCB-5: 1/2" standard
SCB-6: 3/4", 1" standard
SCB-8: 1 1/4", 1 1/2" standard
1", 1 3/8" special order
- Stop collar:
1, 2 or 4 stop standard
Other stop collars are available as specials

Example: SCB-8, CCW, 115VAC, 1-1/4" bore, 1 stop collar.

SCB Series	-8	CCW	115VAC	1-1/4"	1
	1	2	3	4	5
	6				

Super CB-5 Clutch/Brake

Dimensions in. (mm)

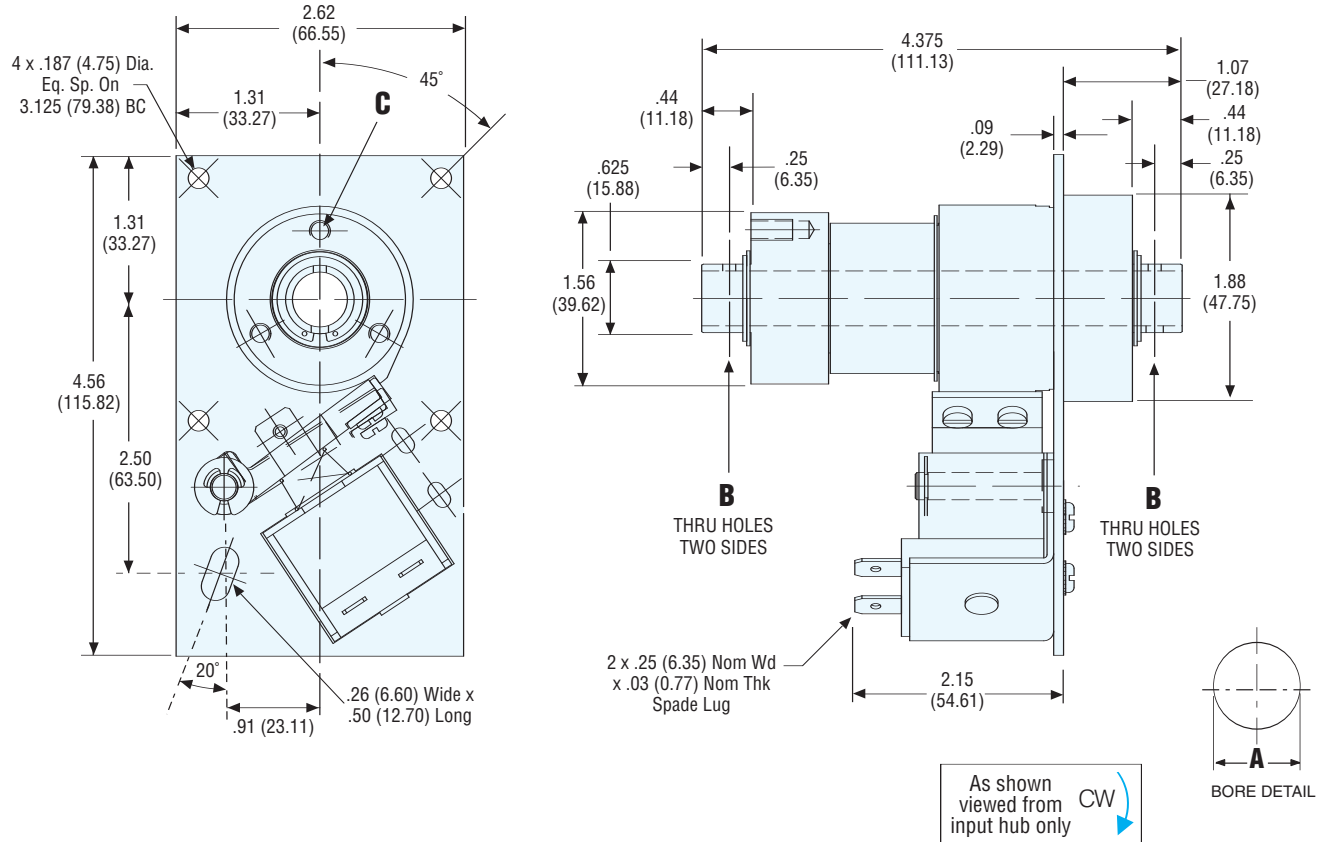

Bore Sizes

	Bore A	Pin Hole B	Mtg. Holes C	Set Screws D
English in. (mm)	.5005-.5025 (12.712-12.764)	.125 (3.175)	3x #10-32 UNF-2B Eq. Sp. on 1.25 BC	#8-32 x .25 Skt. Set Screw
Metric mm (in.)	12.0 H9 (.4724-.4741)	3.0 (.117-.121)	3x M5 x 0.8 on 31.75 BC	

All dimensions are nominal unless otherwise noted.

SCB-5 Part Numbers

Bore Size	Voltage	Rotation	Stops		
			1	2	4
0.5"	24 VDC	CW	325-17-001	325-17-002	325-17-003
		CCW	325-27-001	325-27-002	325-27-003
0.5"	115 VAC	CW	325-17-004	325-17-005	325-17-006
		CCW	325-27-004	325-27-005	325-27-006

These are the most commonly requested parts – other voltages (such as 12VDC and 90VDC), bores and stop collars are available.

Electrical Data (±10%)

Voltage	Current (amps)	Resistance (ohms)	Status
115 AC 60 Hz	.10*	280	Standard
24 DC	.32	74	Standard
12 DC	.73	16.4	Option
90 DC	.10	936	Option

(Coils are rated for continuous duty)

*115 AC—Inrush current .22 amps, Holding current .09 amps

Specifications

Static Torque	250 lb.in.
Maximum anti-overnun holding capability	125 lb.in.
Maximum anti-back holding capability	125 lb.in.
Inertia, rotating parts	.236 lb.in. ²
Maximum radial bearing load at maximum speed	35 lbs.
Maximum operating speed	750 RPM
Response time, voltage on at full speed	27 MS
Weight	3 lbs.

Super CB-6 Clutch/Brake

Dimensions in. (mm)

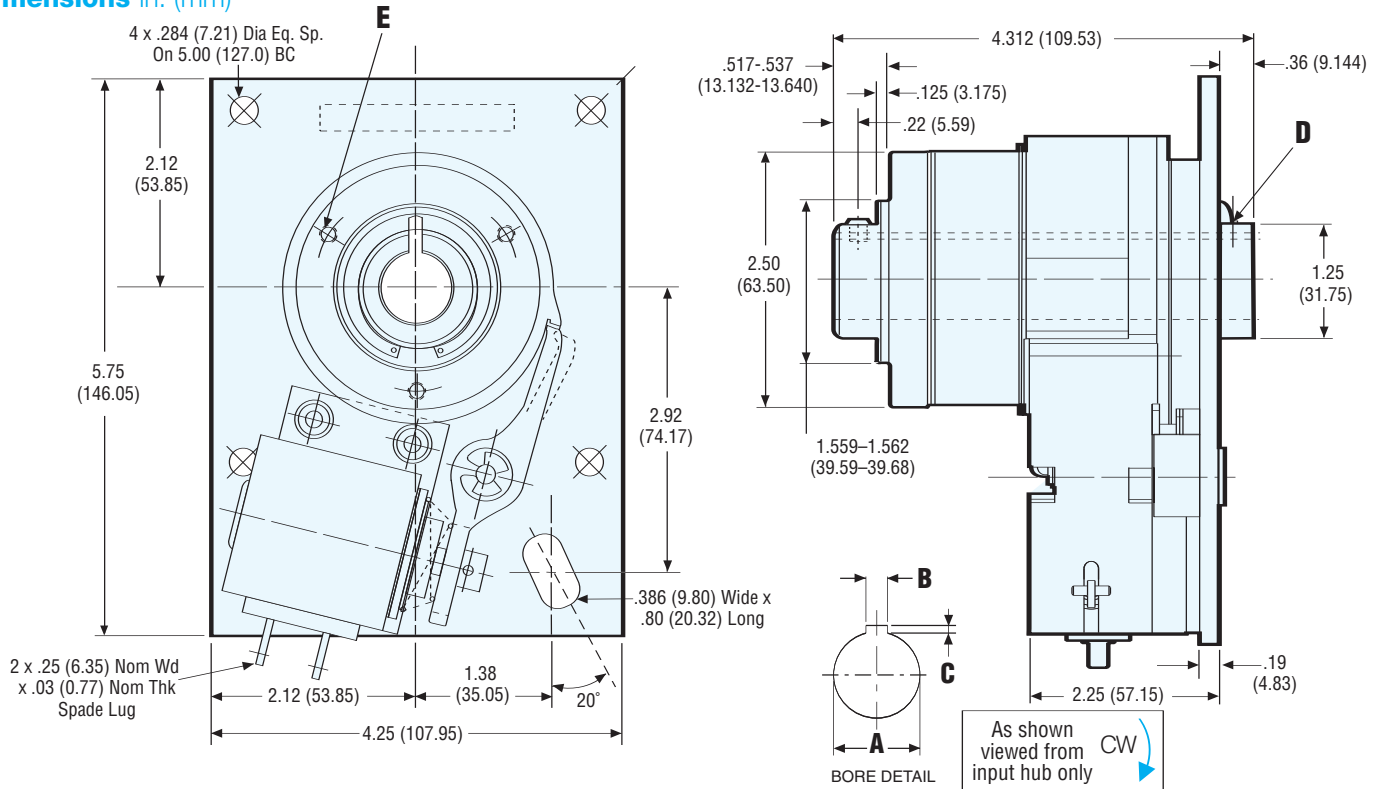

Bore & Keyway Sizes

	Bore A	Keyway Width B	Keyway Depth C	Set Screws/Pin Hole D	Mtg. Holes E
English in. (mm)	.7505-.7525 (19.062-19.114)	.1875 (4.7625)	.09375 (2.381)	2x #10-32 UNF-2B	3x #1/4-20 UNC-2B Eq. Sp. on 2.062 BC
	1.0005-1.0025 (25.412-25.464)	—	—	2x .187 Hole (4.7498)	3x #1/4-20 UNC-2B Eq. Sp. on 2.062 BC
Metric mm (in.)	20.0 H9 (.7874-.7894)	6.0 (.2362)	2.8 (.1102)	2x M5 x 0.8 x 5.0 Lg. Hex Skt. Set Screw	3x M6 x 1.0 on 52.38 BC
	25.0 H9 (.9842-.9862)	—	—	2x 5.0 Hole (.191-.203)	3x M6 x 1.0 on 52.38 BC

All dimensions are nominal unless otherwise noted.

SCB-6 Part Numbers

Bore Size	Voltage	Rotation	Stops		
			1	2	4
0.75"	24 VDC	CW	326-17-007	326-17-008	326-17-009
		CCW	326-27-007	326-27-008	326-27-009
0.75"	115 VAC	CW	326-17-019	326-17-020	326-17-021
		CCW	326-27-019	326-27-020	326-27-021
1.0"	24 VDC	CW	326-17-010	326-17-011	326-17-012
		CCW	326-27-010	326-27-011	326-27-012
1.0"	115 VAC	CW	326-17-022	326-17-023	326-17-024
		CCW	326-27-022	326-27-023	326-27-024

These are the most commonly requested parts – other voltages (such as 12VDC and 90VDC), bores and stop collars are available.

Electrical Data (±10%)

Voltage	Current/Resistance		Status
	(amps)	(ohms)	
115 AC 60 Hz	.33*	53.5	Standard
24 DC	.60	39.8	Standard
12 DC	1.15	10.4	Option
90 DC	.15	598	Option

(Coils are rated for continuous duty)

*115 AC—Inrush current .62 amps, Holding current .31 amps

Specifications

Static Torque	500 lb.in.
Maximum anti-overnun holding capability	300 lb.in.
Maximum anti-back holding capability	300 lb.in.
Inertia, rotating parts	1.718 lb.in. ²
Maximum radial bearing load at maximum speed	65 lbs.
Maximum operating speed	500 RPM
Response time, voltage on at full speed	45 MS
Weight	7 lbs.

Super CB-8 Clutch/Brake

Dimensions in. (mm)

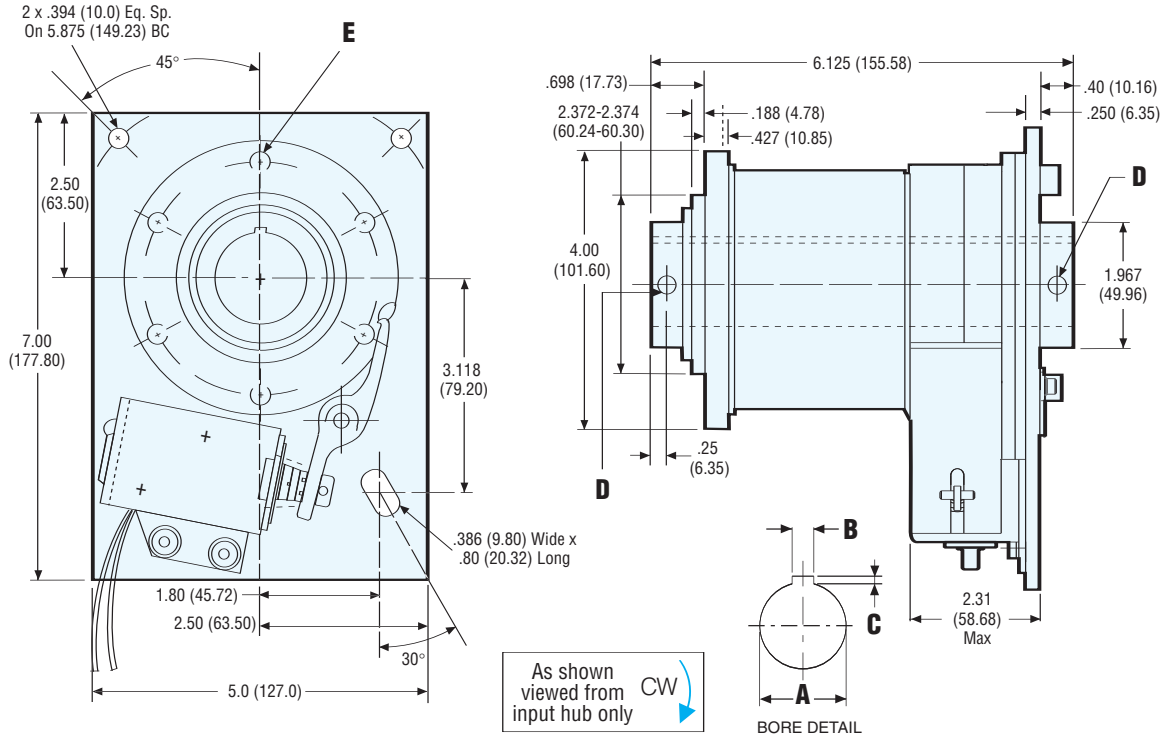

Bore & Keyway Sizes

		Bore A	Keyway Width B	Keyway Depth C	Set Screws D	Mtg. Holes E
English	in.	1.2505-1.2525	.3125	.15625	2x #1/4-20 UNC-2B	6x 5/16-18 UNC-2B
	(mm)	(31.762-31.814)	(7.9375)	(3.9688)		Eq. Sp. on 3.375 BC
		1.5005-1.5025	.375	.125	2x #1/4-20 UNC-2B	6x 5/16-18 UNC-2B
		(38.112-38.164)	(9.525)	(3.175)		Eq. Sp. on 3.375 BC
Metric	mm	35.0 H9	10.0	3.3	2x M6 x 1.0 x 10.0	6x M8 x 1.25 on
	(in.)	(1.3780-1.3804)	(.3937)	(.1299)	Lg. Hex Skt. Set Screw	85.73 BC
		40.0 H9	—	—	2x M6 x 1.0 x 10.0	6x M8 x 1.25 on
		(1.5784-1.5772)	—	—	Lg. Hex Skt. Set Screw	85.73 BC

All dimensions are nominal unless otherwise noted.

SCB-8 Part Numbers

Bore Size	Voltage	Rotation	Stops		
			1	2	4
1.25"	24 VDC	CW	328-17-019	328-17-020	328-17-021
		CCW	328-27-019	328-27-020	328-27-021
1.25"	115 VAC	CW	328-17-043	328-17-044	328-17-045
		CCW	328-27-043	328-27-044	328-27-045
1.5"	24 VDC	CW	328-17-013	328-17-014	328-17-015
		CCW	328-27-013	328-27-014	328-27-015
1.5"	115 VAC	CW	328-17-037	328-17-038	328-17-039
		CCW	328-27-037	328-27-038	328-27-039

These are the most commonly requested parts – other voltages (such as 12VDC and 90VDC), bores and stop collars are available.

Electrical Data (±10%)

Voltage	Current (amps)	Resistance (ohms)	Status
115 AC 60 Hz	.33*	53.5	Standard
24 DC	.94	25.4	Standard
12 DC	1.87	6.43	Option
90 DC	.24	378	Option

(Coils are rated for continuous duty)

*115 AC—In rush current .62 amps, Holding current .31 amps

Specifications

Static Torque	2,500 lb.in.
Maximum anti-overrun holding capability	600 lb.in.
Maximum anti-back holding capability	600 lb.in.
Inertia, rotating parts	12.840 lb.in. ²
Maximum radial bearing load at maximum speed	300 lbs.
Maximum operating speed	300 RPM
Response time, voltage on at full speed	50 MS
Weight	15 lbs.