

## Base Mounted Clutch/Brake Combinations in a Rugged Housing

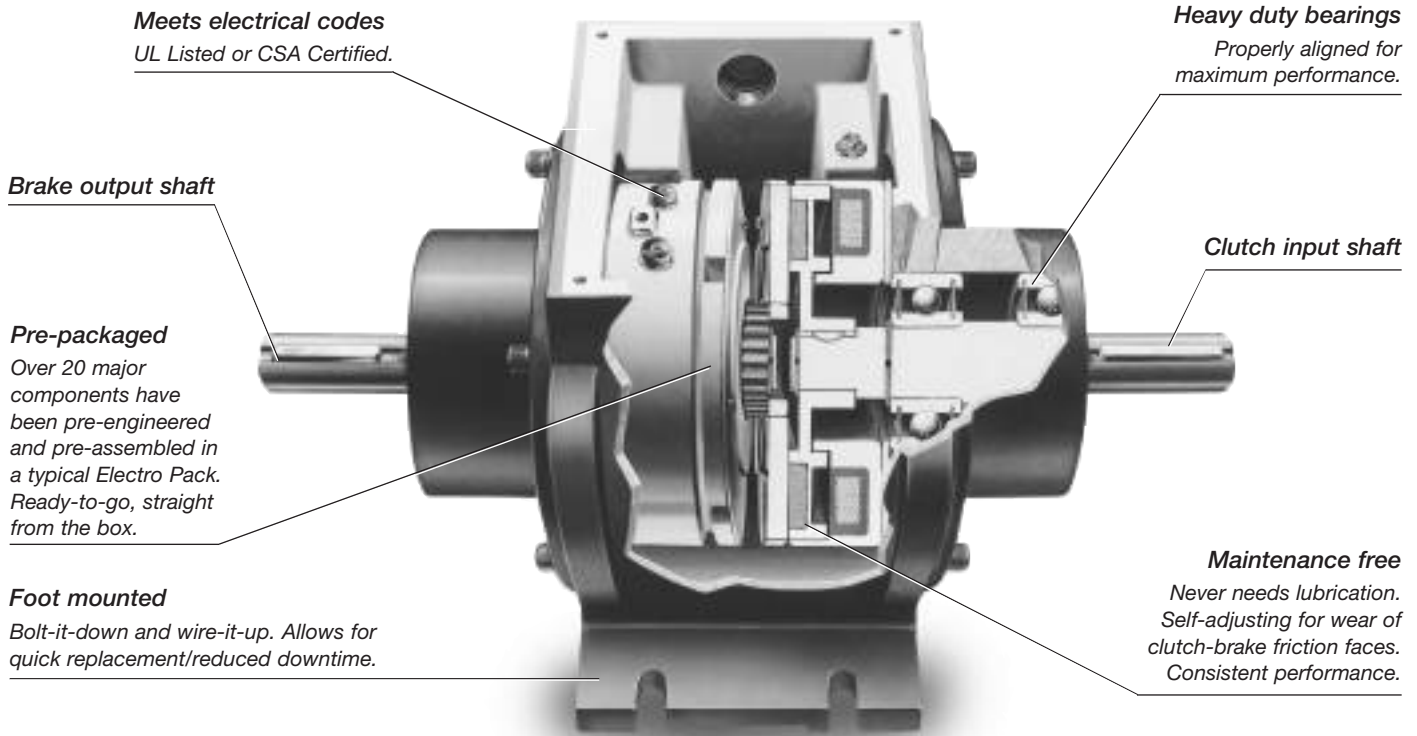

Electro Packs are rugged, pre-assembled clutch and brake combinations in an enclosed, foot mounted housing.

They are factory aligned and pre-assembled and have been designed to mate easily with industry standard motors and reducers with v-belts, pulleys, chain and sprockets, in line couplings and timing belt drives.

### Features

- Bolt-it-down and wire-it-up . . . it's ready to go!
- Maintenance free
- A wide torque range from 15 lb. in. to 1350 lb. ft.

### Typical Application

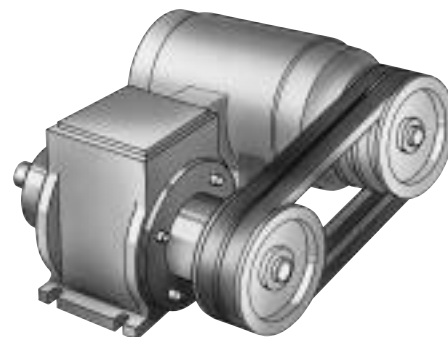

A foot mounted Electro Pack combines with a motor in a parallel shaft drive application.

### Horsepower vs. Shaft Speed

HP ▼	SHAFT SPEED AT CLUTCH (IN RPM)																					
	100	200	300	400	500	600	700	800	900	1000	1100	1200	1500	1800	2000	2400	3000	3600	4000	4500	5000	
1/50																						
1/20											EP-170											
1/12																						
1/8																						
1/6																						
1/4											EP-250											
1/3																						
1/2																						
3/4											EP-400											
1																						
1-1/2																						
2											EP-500											
3																						
5																						
7-1/2																						
10											EP-825											
15																						
20																						
25																						
30																						
40																						

### Selection Procedure

Determine the shaft speed at the Electro Pack location. The number listed at the intersection of horsepower and speed is the size Electro Pack you require.

### Part Numbers

Model No.	Voltage DC	Part No.
EP-170	6	5633-273-002
	24	5633-273-003
	90	5633-273-005
EP-250	6	5130-273-031
	24	5130-273-032
	90	5130-273-034
EP-400	6	5131-273-009
	24	5131-273-010
	90	5131-273-011
EP-500	6	5230-273-003
	24	5230-273-011
	90	5230-273-002
EP-825	6	5231-273-003
	24	5231-273-004
	90	5231-273-002
EP-1000	6	5232-273-003
	24	5232-273-005
	90	5232-273-002
EP-1525	6	5234-273-003
	90	5234-273-002
EP-1525HT	24	5234-273-017
	90	5234-273-012

When ordering, specify size, voltage, and part numbers.

### Specifications

Electro-Pack Size	Horsepower @ 1800 RPM	Static Torque	Max. RPM	Voltage DC
EP-170	1/8	15 lb. in.	10,000	6, 24 or 90
EP-250	1/2	70 lb. in.	7,500	6, 24 or 90
EP-400	1	270 lb. in.	4,500	6, 24 or 90
EP-500	2	50/40 lb. ft.	4,000	6, 24 or 90
EP-825	7-1/2	125 lb. ft.	3,600	6, 24 or 90
EP-1000	10	240 lb. ft.	3,000	6, 24 or 90
EP-1525	25	700 lb. ft.	1,800	6 or 90
EP-1525HT	40	1350 lb. ft. clutch 700 lb. ft. brake	1,800	24, 90

## EP-170, EP-250, EP-400

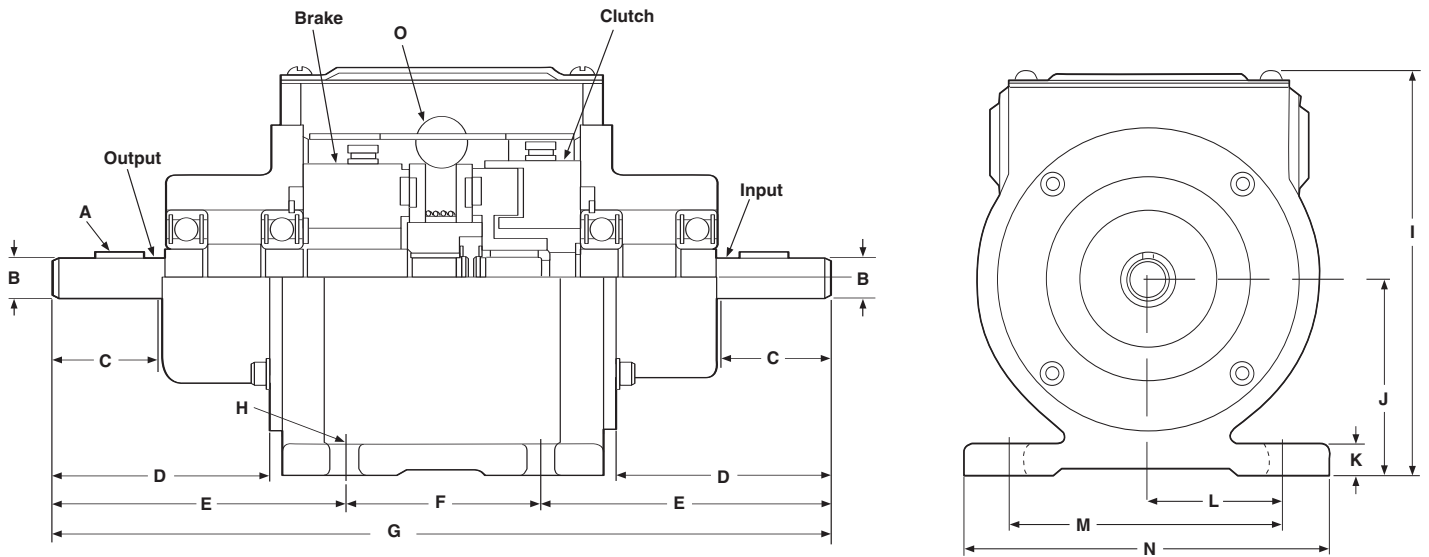

All dimensions are nominal, unless otherwise noted.

Size	A	B	C Min.	D	E	F	G Max.	H	I	J	K	L	M	N	O
170	3/32 x 3/64	.3745 .3735 Dia.	.750	1.406	2.203	1.500	6.000	.250 Wide (4 slots)	3.437	1.662 1.652	.312	1.110	2.220	3.250	1/2 14 NPT Conduit x 2
250	1/8 x 1/16	.4995 .4985 Dia.	1.250	2.468	3.312	2.250	8.968	.312 Wide (4 slots)	5.281	2.318 2.308	.375	1.625	3.250	4.250	1/2 14 NPT Conduit x 2
400	3/16 x 3/16 x 1-1/2	.7495 .7485	1.875	3.515	4.593	2.500	11.781	.312 Wide (4 slots)	6.937	3.474 3.464	.500	2.578	5.156	6.000	1/2 14 NPT Conduit x 2

### Specifications

Model Size	Voltage DC	Static Torque lb. in.	Inertia*—WR <sup>2</sup> (lb-in <sup>2</sup> )		Max. RPM	Weight lbs.
			Output	Input		
EP-170	6	15	.031	.036	10,000	2.5
	24	15	.031	.036	10,000	2.5
	90	15	.031	.036	10,000	2.5
EP-250	6	70	.331	.293	7,500	7.1
	24	70	.331	.293	7,500	7.1
	90	70	.331	.293	7,500	7.1
EP-400	6	270	2.566	2.222	4,500	19.7
	24	270	2.566	2.222	4,500	19.7
	90	270	2.566	2.222	4,500	19.7

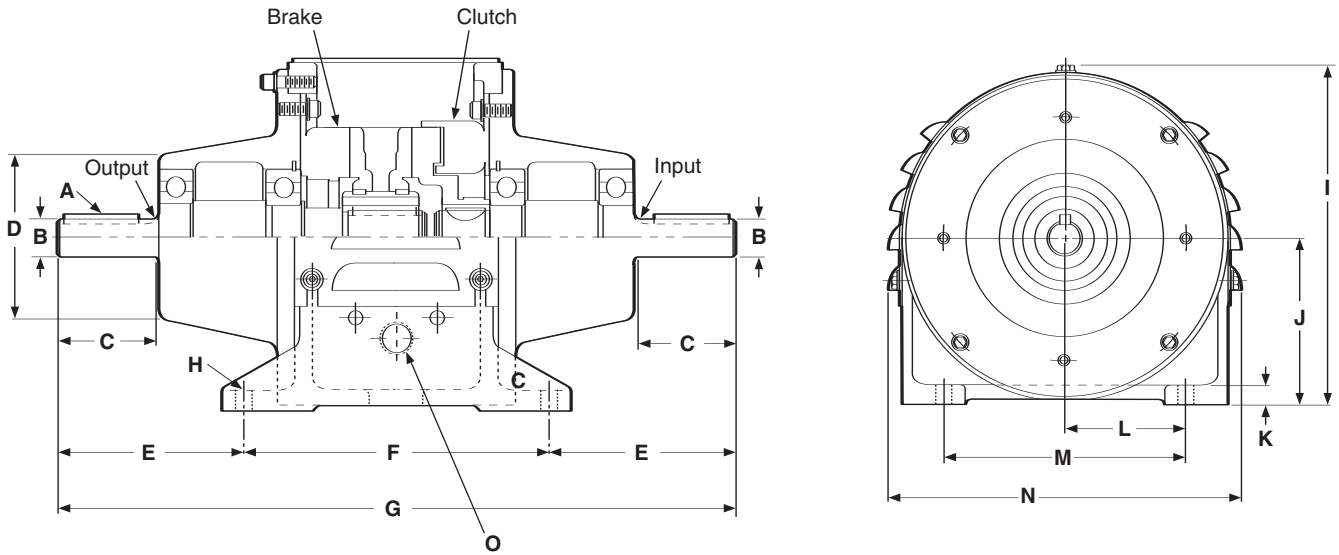

All dimensions are nominal, unless otherwise noted.

Size	A	B Dia.	C Min.	D Max. Dia.	E	F	G Max.	H Dia. (4 holes)	I	J	K	L	M	N Max.	O
500	3/16 x 1-3/4	.8750 .8745	2.218	3.796	4.234	7.000	15.515	.406 (4 holes)	8.218	4.004 3.992	.500	2.937	5.875	8.734	1/2 NPT Conduit x 2

**Specifications**

Model Size	Voltage DC	Unit	Static Torque	Inertia*—WR <sup>2</sup> lb.ft. <sup>2</sup>	Max. RPM	Weight lbs.
EP-500	6, 24 and 90	Clutch Brake	50 40	.039 .063	4000	56

**EP-825**

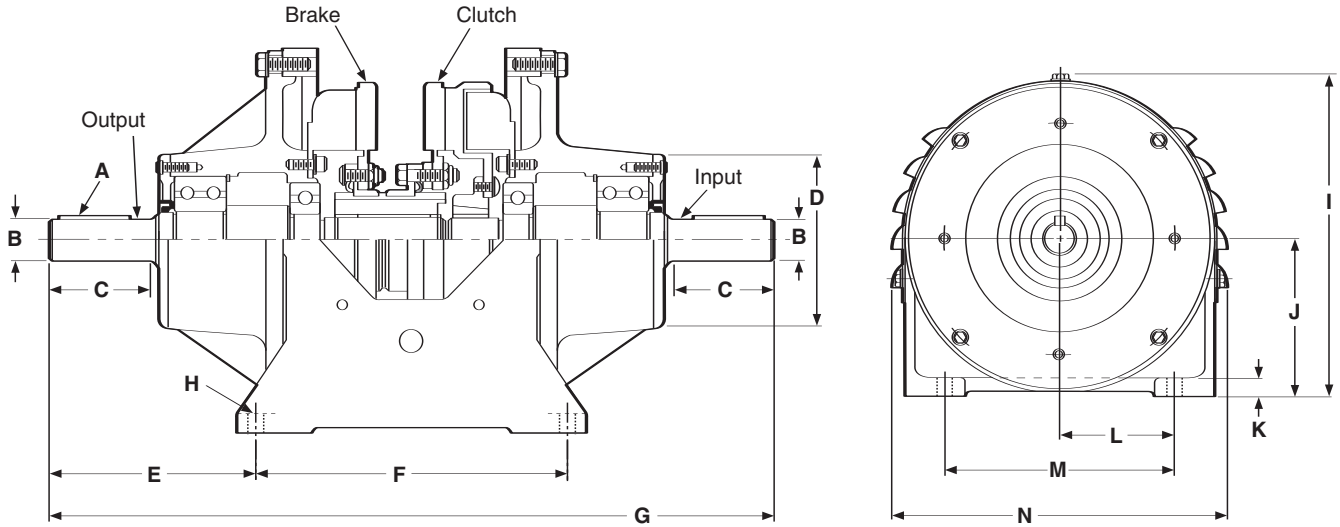

All dimensions are nominal, unless otherwise noted.

Size	A	B Dia.	C Min.	D Max. Dia.	E	F	G Max.	H	I	J	K	L	M	N Max.
825	1/4 x 1/4 x 2	1.1250 1.1245	2.875	5.000	5.734	8.500	20.031	.406 Dia. (4 holes)	10.812	5.254 5.252	.562	4.250	8.500	11.609

**Specifications EP-825**

Model Size	Voltage DC	Unit	Static Torque	Inertia*–WR <sup>2</sup> lb.ft. <sup>2</sup>	Max. RPM	Weight lbs.
EP-825	6, 24 & 90	Clutch	125	.651	3600	123
		Brake	125	.242		

**Specifications EP-1000**

Model Size	Voltage DC	Static Torque	Inertia*–WR <sup>2</sup> (lb-ft <sup>2</sup> )		Max. RPM	Weight lbs.
			Output Side	Input Side		
EP-1000	6	240 lb.ft.	1.45	1.01	3000	288
	24	240 lb.ft.	1.45	1.01	3000	288
	90	240 lb.ft.	1.45	1.01	3000	288

All dimensions are nominal, unless otherwise noted.

Size	A	B Dia.	C Min.	D Dia.	E	F	G Max.	H	I	J	K	L	M	N Max.
1000	1/2 x	1.875	4.750	5.687	8.250	12.250	28.750	.656 Dia. (4 holes)	12.500	6.255	.718	5.000	10.000	12.875
	1/2 x	1.874								6.241				
	3-3/4													

**EP-1000**

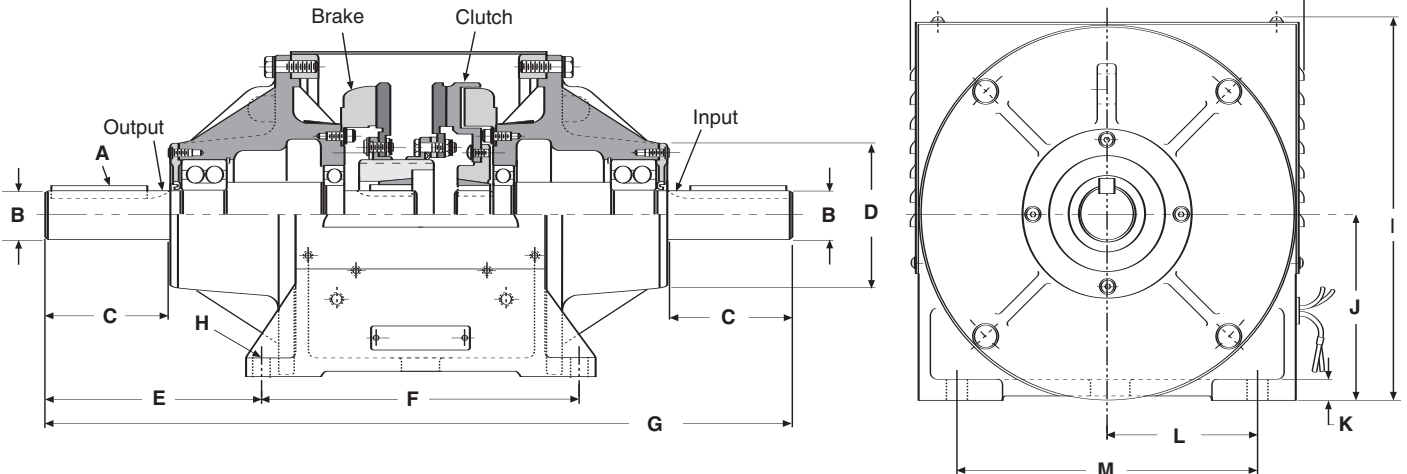

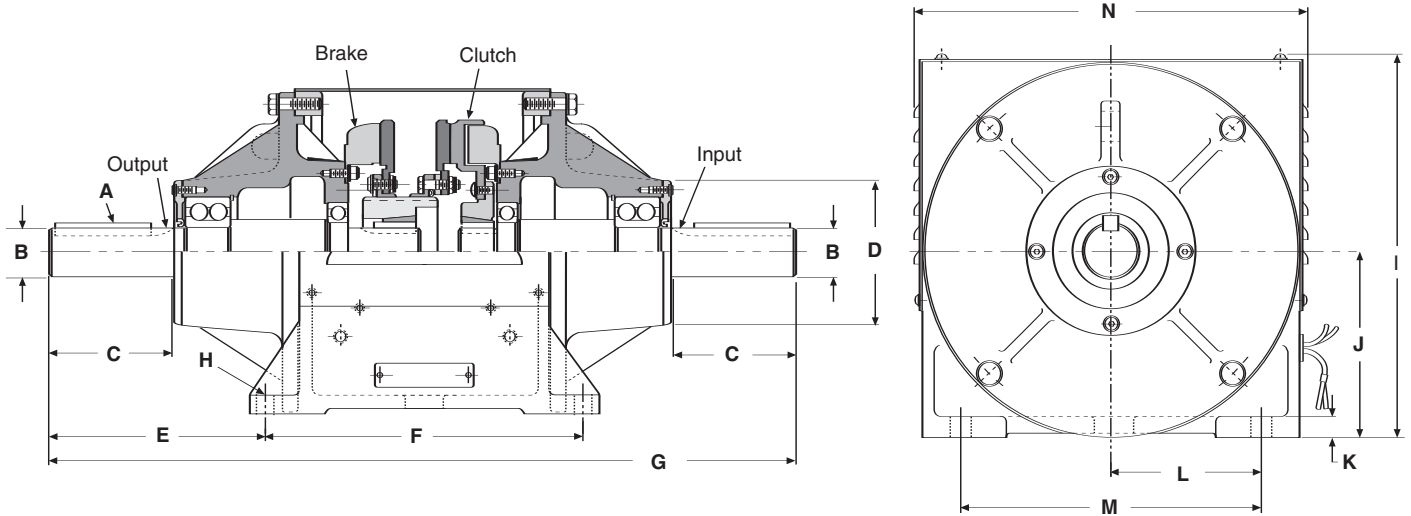

All dimensions are nominal, unless otherwise noted.

Size	A	B Dia.	C Min.	D Max. Dia.	E	F	G Max.	H	I	J	K	L	M	N Max.
1525	5/8 x	<u>2.375</u>						.796 Dia.		<u>9.005</u>				
	5/8 x	2.374	5.750	7.500	8.468	16.500	33.500	(4 holes)	18.250	8.991	1.000	7.000	14.000	18.875
	4-1/4													
1525HT	5/8 x	<u>2.375</u>						.796 Dia.		<u>9.005</u>				
	5/8 x	2.374	5.750	7.500	8.468	16.500	33.500	(4 holes)	18.250	8.991	1.000	7.000	14.000	18.875
	4-1/4													

**Specifications**

Model Size	Voltage DC	Unit	Static Torque lb.ft.	Inertia*—WR <sup>2</sup> lb.ft. <sup>2</sup>		Max. RPM	Weight lbs.
				Output	Input		
EP-1525	6, 90	Clutch	700	7.89	5.68	1800	655
		Brake	700				
EP-1525HT	24, 90	Clutch	1350	7.89	6.41	1800	656
		Brake	700				

## PerformancePlus™ clutch/brake combination in a foot mounted housing

Single point wire exit

### Pre-packaged

Major components have been pre-engineered and pre-assembled in a typical Electro Pack. Ready-to-go, straight from the box.

PerformancePlus™ Electro Packs use ceramic friction system technology. This technology has been in use for many years in specialized applications. Through the development of advanced manufacturing techniques, the improved performance of ceramic friction materials are now available as standard products off the shelf.

PerformancePlus™ Electro Packs with ceramic friction material are rugged, pre-assembled clutch and brake combinations in base mounted housings. They have been designed to be installed in standard power transmission systems with V-belts and pulleys, chain and sprockets, in line couplings, and timing belt drives.

When your application calls for a long life clutch/brake because of high cycle rates or demanding consistency, choose the PerformancePlus solution.

- Bolt-it-down and wire-it-up . . . it's ready to go!
- Available in two size; 170 and 250. Standard voltages are 24V and 90V DC.
- Maintenance free.
- Ideal for use with CBC 1000 indexers and CBC 700 OEX control.

PerformancePlus™ . . . the demanding application choice.

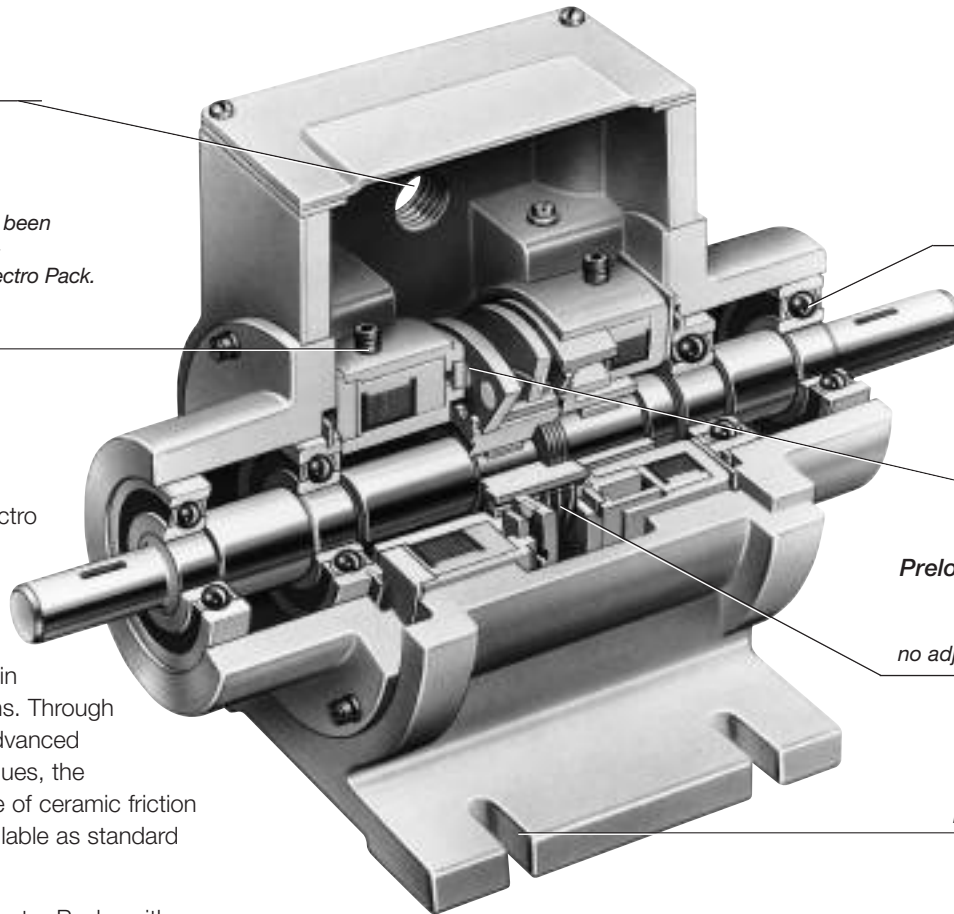

**Heavy duty bearings**  
Properly aligned for maximum performance.

**Ceramic on ceramic friction system**  
Longer life, and consistent torque.

**Preload armature springs**  
Fast response, accurate repeatability, no adjustments for life of unit.

**Foot mounted**  
Bolt-it-down, wire-it-up.

### EP-C Product Life

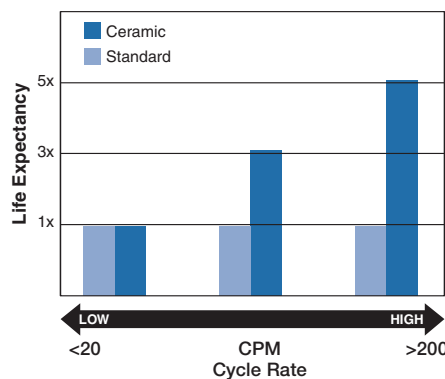

### Extended Life for High Cycle Rate Use

Ceramic faced clutches and brakes have been designed specifically for rapid cycling applications to satisfy today's needs for high speed equipment. Ceramic friction material provides excellent wear resistance that extends life 3 to 5 times that of standard clutch/brakes in demanding applications.

### EP-C Cycle Repeat

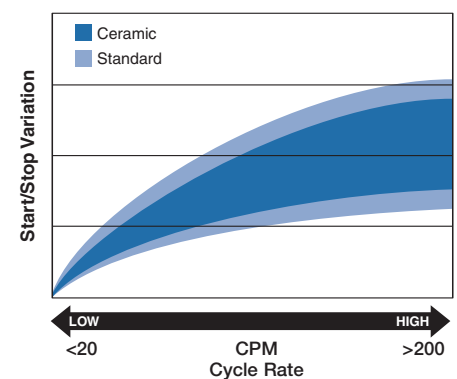

### Consistent Torque and Cycle Repeatability

Preloaded armatures keep the ceramic friction surfaces in light contact, providing consistent torque and cycle-to-cycle repeatability. Variation is reduced by up to 30% over standard units.

### Controllability Smooth Start/Stop

With the ceramic friction surfaces always in contact, dynamic torque response is fast and precise. When used with a CBC-700 over-excitation control and CBC-1000 programmable counter, exceptional closed loop clutch/brake performance can be achieved approaching that of more expensive motion control technologies – The PerformancePlus difference!

### Selection

PerformancePlus Electro Packs are best suited for high energy applications where long life is a premium concern. The harder a ceramic friction surface is worked, the more wear life benefit is achieved. For slower cycle rates, up to 75 cycles per minute, dependable standard clutch/brakes are still a good choice.

For high cycle rates and high energy use (generally more than 50 cycles/minute for EP-170's and EP-250's) PerformancePlus clutch/brakes are the choice.

Technical considerations for sizing and selection are torque and heat dissipation. Each merits careful consideration, especially heat dissipation. Over temperature use will have an adverse effect on bearing life and coil wire insulation integrity.

For proper sizing information, refer to the Horsepower vs. Shaft Speed chart, and the technical sizing considerations below. When ordering, specify size, voltage, and part number.

### Typical Applications

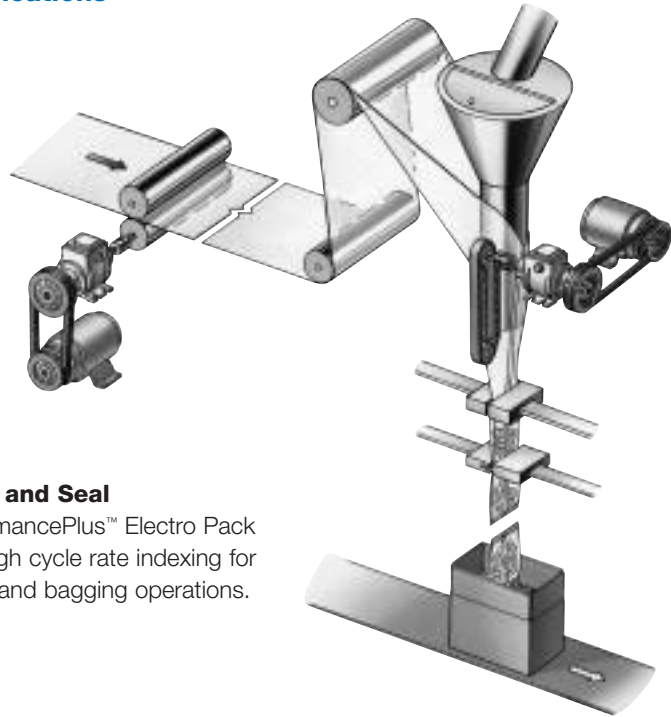

#### Form, Fill and Seal

The PerformancePlus™ Electro Pack provides high cycle rate indexing for packaging and bagging operations.

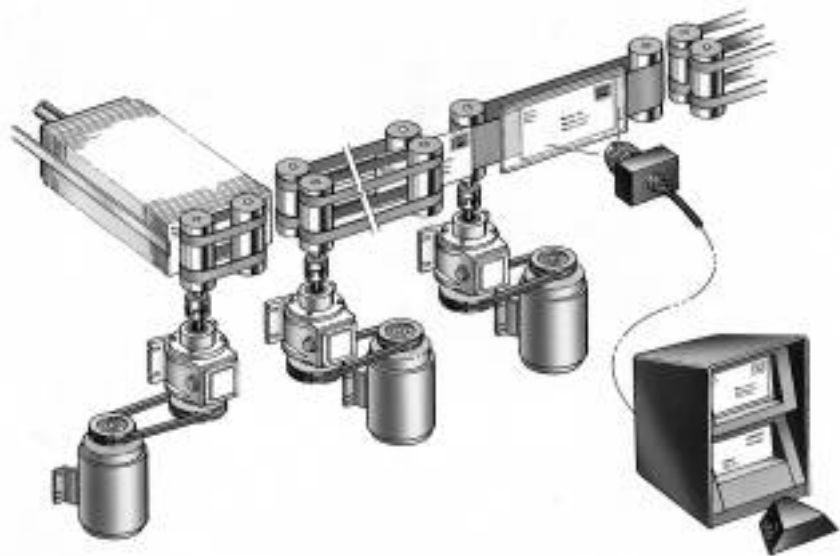

#### Mail Processing

The PerformancePlus Electro Pack provides fast cycling and accurate starting and stopping.

### Horsepower vs. Shaft Speed

HP	SHAFT SPEED AT CLUTCH (IN RPM)																					
▼	100	200	300	400	500	600	700	800	900	1000	1100	1200	1500	1800	2000	2400	3000	3600	4000	4600	5000	
1/50																						
1/20																						
1/12																						
1/8																						
1/6																						
1/4																						
1/3																						
1/2																						
1																						

EP-170-C

EP-250-C

## Selection/Ordering Information

### Heat Dissipation Sizing

Friction surfaces slip during the initial period of engagement and, as a result, heat is generated. The clutch/brake selected must have a heat dissipation rating greater than the heat generated by the application. Therefore, in high inertia or high cycle rate applications, it is necessary to check the heat dissipation carefully. Inertia, speed and cycle rate are the required parameters.

These curves show the heat dissipation capability of the ceramic units.

#### EP-170-C

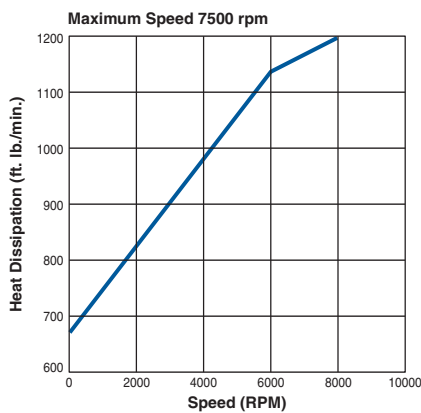

#### EP-250-C

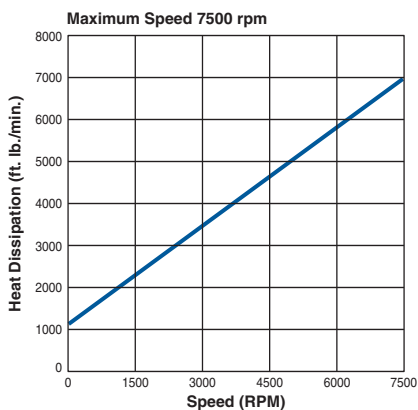

Heat dissipation requirement is calculated as follows:

$$E = 1.7 \times WR^2 \times \left(\frac{N}{100}\right)^2 \times F$$

where:

- E = Heat (lb.ft./min.)  
 WR<sup>2</sup> = Total reflected inertia at the clutch/brake shaft. Include the clutch/brake output inertia. (lb.ft.<sup>2</sup>)  
 N = Speed in revolutions per minute. (RPM)  
 F = Cycle rate in cycles per minute. (CPM)

Compare the calculated heat generated in the application to the unit ratings using the heat dissipation curves. Select the appropriate unit that has adequate heat dissipation ability.

### Dynamic Torque Sizing

These curves show the average dynamic torque during the slip period of engagement. Find the dynamic torque value on the curve at the clutch/brake input speed.

#### EP-170-C EP-250-C

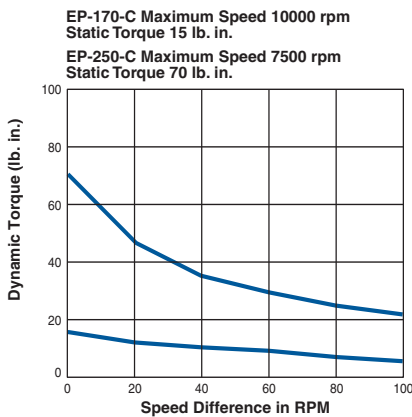

For most applications, the correct size clutch/brake can be selected from the horsepower/shaft speed selection chart. Determine the motor horsepower and the RPM at the clutch/brake. The correct size unit is shown at the intersection of horsepower and shaft speed.

If the static torque requirements are known, refer to the technical ratings chart to select a unit.

### Torque Ratings

Model Size	Max. RPM	Static Torque	Voltage DC
EP-170-C	10,000	15 lb. in.	24 & 90
EP-250-C	7500	70 lb. in.	24 & 90

For some applications, the torque requirement is determined by the time allowed to accelerate and decelerate the load. (This time is generally specified in milliseconds.) For these applications, it is necessary to determine the torque requirement based on load inertia and the time allowed for engagement.

The torque requirements are calculated as follows:

$$T = \frac{WR^2 \times N}{308 \times t}$$

where:

- T = Average Dynamic Torque (lb. ft.)  
 (For EP selection, multiply by 12 to convert to units of lb. in.)  
 WR<sup>2</sup> = Total reflected inertia at the clutch/brake shaft. Include the clutch/brake output inertia. (lb. ft.<sup>2</sup>)  
 N = Speed in revolutions per minute. (RPM)  
 t = Time allowed for the engagement (sec)

Compare the calculated torque requirement with the average dynamic torque ratings. Select a unit with adequate torque. If the unit selected on torque is different than the unit selected based on heat, select the larger unit size.

### Part Numbers

Model Size	Voltage DC	Part No.
EP-170-C	24V	P/N 5633-273-018
	90V	P/N 5633-273-019
EP-250-C	24V	P/N 5130-273-053
	90V	P/N 5130-273-054

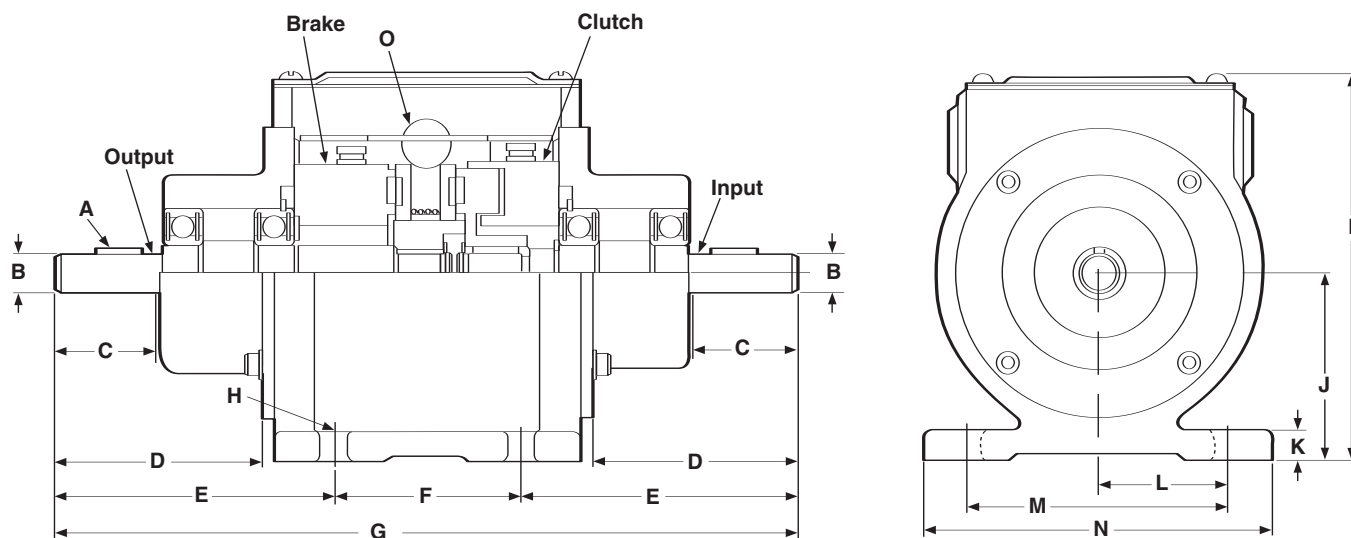

All dimensions are nominal, unless otherwise noted.

Size	A	B Dia.	C Min.	D	E	F	G Max.	H	I	J	K	L	M	N	O
170-C	3/32 x 3/64	.3745 .3735	.750	1.406	2.203	1.500	6.000	.250 Wide (4 slots)	3.437	1.662 1.652	.312	1.125	2.250	3.250	14 NPT 1/2 conduit
250-C	1/8 x 1/16	.4995 .4985	1.230	2.468	3.312	2.250	8.968	.312 Wide (4 slots)	5.281	2.318 2.308	.375	1.625	3.250	4.250	14 NPT 1/2 conduit

### Specifications

Model Size	Voltage DC	Unit	Static Torque lb. in.	Inertia*–WR <sup>2</sup> lb.ft. <sup>2</sup>		Max. RPM	Weight lbs.
				Output	Input		
170-C	24	Clutch	15	.031	.036	10,000	2.8
		Brake	15	.031	.036	10,000	2.8
	90	Clutch	15	.031	.036	10,000	2.8
		Brake	15	.031	.036	10,000	2.8
250-C	24	Clutch	70	.331	.293	7,500	7.5
		Brake	70	.331	.293	7,500	7.5
	90	Clutch	70	.331	.293	7,500	7.5
		Brake	70	.331	.293	7,500	7.5

**Distribuidor Autorizado e Importador - Arten Freios e Embreagens Ltda.**

**Fone: (11) 5594-8333 • Fax (11) 5589-2422 - arten@arten.com.br • www.arten.com.br**