

Contamination-Proof Design

Clean, quiet, operation. Nothing can get in, nothing can get out. Enclosed design eliminates damage to the working components. Prevents friction wear particles from escaping.

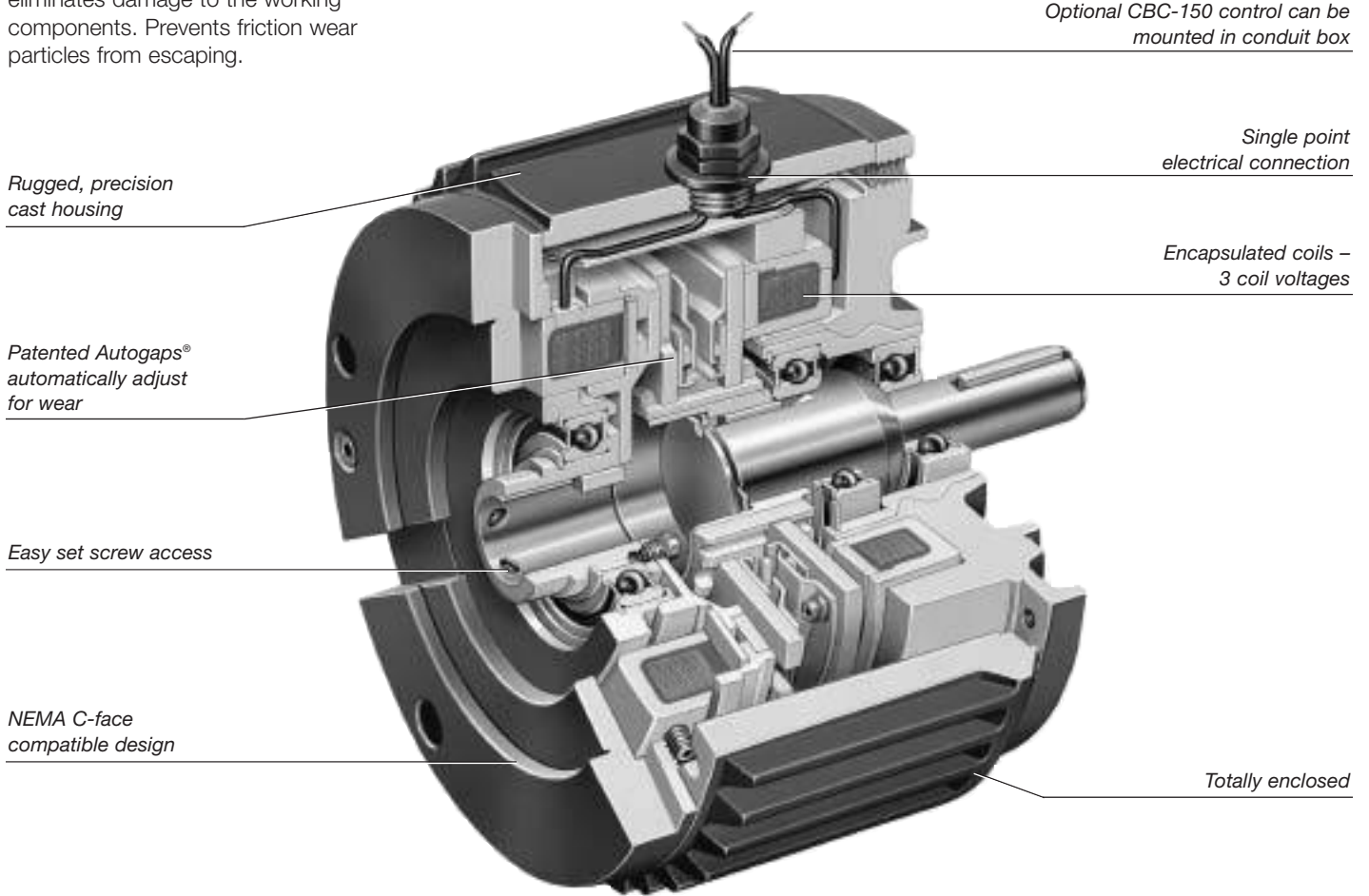

One piece, C-face package completely assembled and factory aligned. Mates easily with standard motors and reducers. Foot mounted package also available. Easy-to-install and no maintenance required.

Bolt-it-down, wire-it-up. UniModule is ready to go. Automatic adjustment for wear. Complete control capability.

Available with built-in power supply or used with separate controls for soft starts and stops . . . or for fast acting, accurate cycling.

- Factory burnished for out-of-box torque
- Superior heat transfer
- Dual endbell for easy repair
- Single point electrical connection
- Optional conduit box
- Optional integral control

Improved Hub Design/Autogap System

- Improved for longer spline life
- Autogap functions over broad current range
- New hub material

Two Versions

EUM Totally Enclosed

EUM (black) units are totally enclosed to keep wear particles in and exclude contaminants and are suitable for most industrial applications.

EUM-W Washdown Unit

EUM-W (white) units are ideal for applications that require frequent washing with high pressure spray systems.

EUM Series Clutch/Brakes and Clutch Combinations



Totally Enclosed Version

The Enclosed UniModule (EUM) packages the hardworking components from EM and UM products into a totally enclosed housing. This rugged housing keeps wear particles in and contaminants out and provides quiet operation. Pre-assembled and pre-aligned at the factory, and pre-burnished for rated torque directly out-of-box.

EUM (black) units are totally enclosed. They are suitable for most industrial applications and tolerate infrequent, light washing. They have aluminum endbells and a finned housing for rapid heat dissipation.

- Keeps contaminants out
- Keeps wear particles in
- Quiet operation
- Finned for heat dissipation
- UL listed when optional conduit box is installed



EUM-W Series Clutch/Brakes Washdown Unit

The washdown version of the EUM uses stainless steel shafting, USDA approved coating, corrosion resistant fasteners and special sealing accessories for use in washdown applications.

EUM-W (white) units are ideal for applications that require frequent washing with high pressure spray systems. Their smooth exterior does not allow food particles, or other contaminants, to get trapped and become host to bacteriological growth.

- USDA approved coating
- Stainless steel shafting
- Sealing (gaskets and plugs)
- Smooth exterior – easy washdown
- Corrosion resistant hardware
- Sealed/shielded bearings
- Baffled ventilation system
- Designed for IP65 enclosure requirements
- UL listed when conduit box is employed
- BISSC Certified

Applications and Mounting Configurations

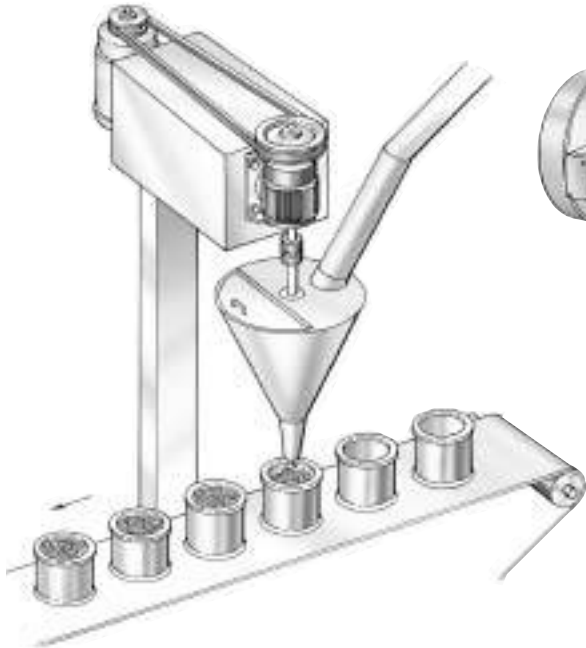

Auger Filler

The totally enclosed design of the EUM UniModule 2030 keeps wear particles in and contaminants out.

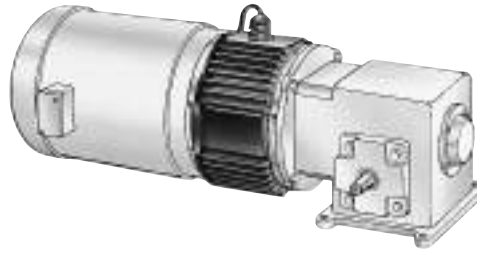

Enclosed UniModule 1040 clutch unit mounted between a C-face motor and reducer.

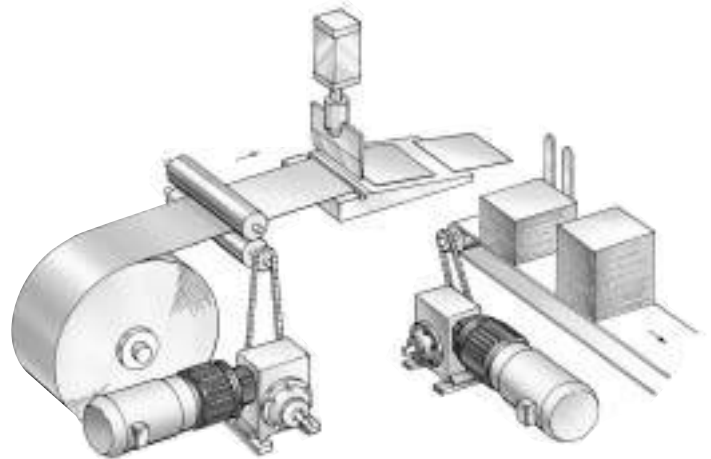

Sheet Cutter

The EUM UniModules 1020 provide quiet, clean, high cycle rate clutch/brake indexing.

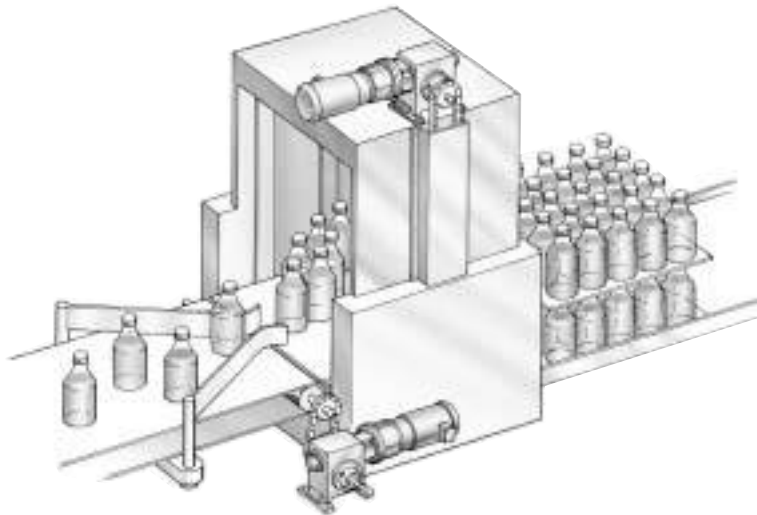

Stacking Operation

The clean design and corrosion resistance of EUM-W UniModules 1020 make them ideal for washdown applications.

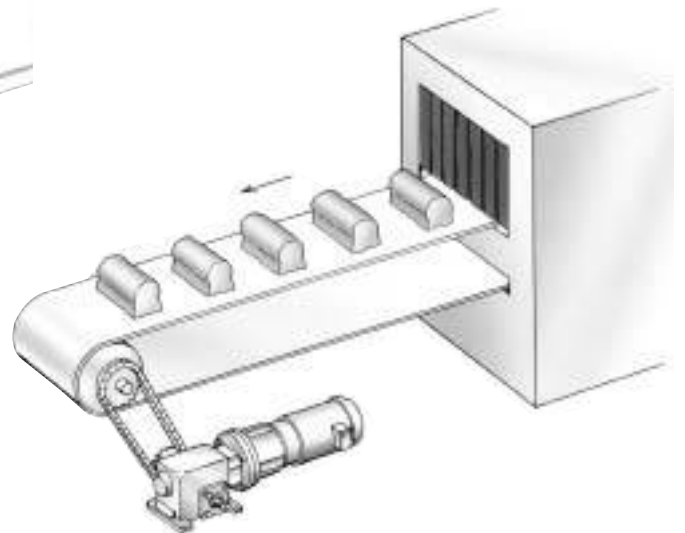

Food Handling

The EUM-W UniModule 1020 has an USDA approved coating which provides cleanliness and safe use in food processing operations.



Enclosed UniModule 2030 assembly base mounted for separate drive mounting.

EUM/EUM-W - Selection Procedure

Warner Electric EUM clutch/brake modules normally mount in either of two methods: NEMA C-face mounting or base mounting.

1. Select Configuration



a. NEMA C-face Mounting (1020 and 1040 Configurations)

Based on the NEMA C-face frame size of the prime mover, select the corresponding clutch/brake package size from the Frame Size Selection chart. Size 100 houses the components of the size 180 in a size 50 frame, while size 215 incorporates size 210 components.

Select either a 1020 or a 1040 (EUM only) configuration. The 1020 is a clutch/brake, while the 1040 is a clutch only. The 2030 configuration is a clutch/brake for base mounting.

Frame Size Selection

NEMA Frame Size	EUM Size
56C/48Y	EUM-50* EUM-100**
182C/143TC 184C/145TC	EUM-180
213C/182TC 215C/184TC	EUM-210
213TC/215TC	EUM-215

*For 56C/48Y C-frame motors 3/4 HP and smaller, the EUM-100 size may be used where extended life is desirable.

**The EUM-100 size is recommended for motors 1 HP and larger.

b. Base Mounting (2030 Configuration)



Enclosed UniModule assemblies may be mounted as separate drive units driven from the prime mover by V-belts, chain and sprockets, couplings, timing belts and other standard power transmission components.

Select the correct size 2030 package from the Horsepower vs. Shaft Speed chart by determining the motor horsepower and RPM at the module location. The correct size EUM is shown at the intersection of the HP and operating speed. For additional sizing information, refer to the technical sizing procedure (step 2).

2. Determine Technical Requirements

Technical considerations for sizing and selection are torque and heat dissipation. Each merits careful consideration, especially heat dissipation as over time, use in excessive temperature environments will have an adverse effect on bearing life and coil wire insulation integrity.

Compare the calculated torque requirement with the average dynamic torque ratings. Select a unit with adequate torque. If the unit selected on torque is different than the unit selected based on heat, select the larger size unit.

Two heat dissipation curves are shown. A fan kit accessory is available for use with these units.

Horsepower vs. Shaft Speed

HP	SHAFT SPEED AT CLUTCH (IN RPM)																	
	100	200	300	400	500	600	700	800	900	1000	1100	1200	1500	1800	2000	2400	3000	3600
1/4																		
1/2															EUM-50			
3/4																		
1															EUM-100/180			
1-1/2																		
2					EUM-210/215													
3																		
5																		
7-1/2																		
10																		

a. Heat Dissipation Sizing

Friction surfaces slip during the initial period of engagement and, as a result, heat is generated. The clutch/brake selected must have a heat dissipation rating greater than the heat generated by the application. Therefore, in high inertia or high cycle rate applications, it is necessary to check the heat dissipation carefully. Inertia, speed and cycle rate are the required parameters.

Heat dissipation requirement is calculated as follows:

$$E = 1.7 \times WR^2 \times (N/100)^2 \times F$$

where:

$$E = \text{Heat (lb. ft./min.)}$$

WR^2 = Total reflected inertia at the clutch/brake shaft. Include the clutch/brake output inertia. (lb.ft.²)

N = Speed in revolutions per minute. (RPM)

F = Cycle rate in cycles per minute (CPM)

Compare the calculated heat generated in the application to the unit ratings using the heat dissipation curves. Select the appropriate unit that has adequate heat dissipation ability.

Enclosed UniModule Heat Dissipation Curves

EUM 50

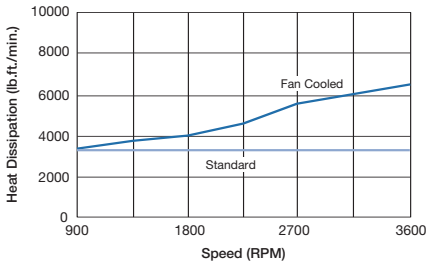

EUM 100/180

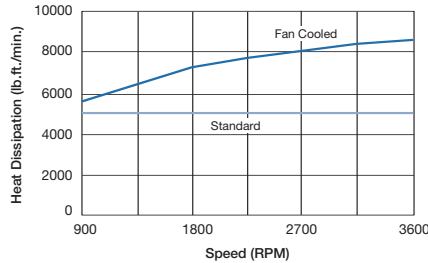

EUM 210/215 (fan not available for 215)

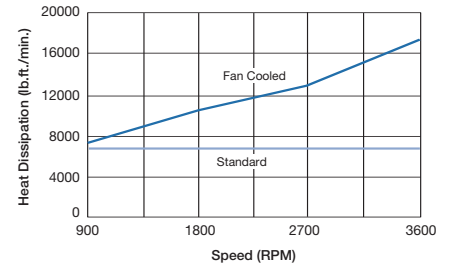

b. Torque Sizing

For most applications, the correct size clutch/brake can be selected from the Horsepower vs. Shaft Speed chart (located at the bottom of this page). Determine the motor horsepower and the RPM at the clutch/brake. The correct size unit is shown at the intersection of horsepower and shaft speed.

If the static torque requirements are known, refer to the technical ratings chart to select a unit.

For some applications, the torque requirement is determined by the time allowed to accelerate and decelerate the load. (This time is generally specified in milliseconds.) For these applications, it is necessary to determine the torque requirement based on load inertia and the time allowed for engagement.

The torque requirements are calculated as follows:

$$T = (WR^2 \times N) / (308 \times t)$$

where:

T = Average Dynamic Torque (lb. ft.)

WR^2 = Total reflected inertia at the clutch/brake shaft. Include the clutch/brake output inertia. (lb. ft.²)

N = Speed in revolutions per minute. (RPM)

t = Time allowed for the engagement (sec)

C-face Clutch/Power-on Brake Dynamic Torque Curves

EUM 50

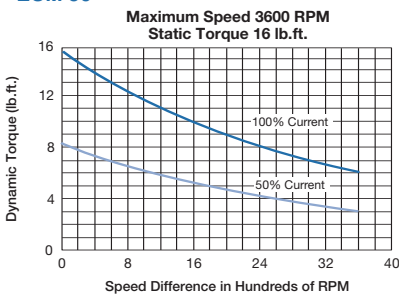

EUM 100/180

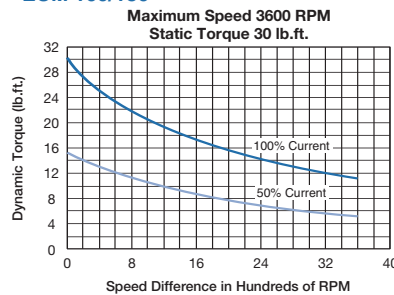

EUM 210/215

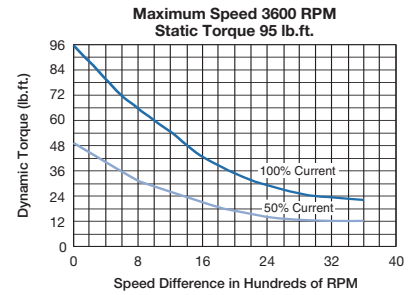

Specifications

UniModule Size	Shaft Dia.	Horsepower	Static Torque lb. ft.	Cycles per Min. @1750 RPM	Max. RPM	Voltage DC	NEMA Frame Size
EUM50	.625	1/4-3/4	16	125	3600	6, 24 or 90	56C/48Y
EUM100		1	30	90	3600	6, 24 or 90	
EUM180	.625	1-2	30	90	3600	6, 24 or 90	182C/143TC 184C/145TC
EUM210	1.125	3-5	95	37	3600	6, 24 or 90	213/182TC 215C/184TC
EUM215	1.375	7-1/2-10	95	37	3600	6, 24 or 90	213TC/215TC

3. Select Options

Warner Electric Enclosed UniModules can be fitted with several accessories to extend their capacity and ease of mounting.

a. Conduit Box

NEMA 4 and UL listed, available in standard and washdown versions.



b. Integral Control

The CBC-150 dual channel control fits into the cover of the conduit box. It is suitable for AC side switching (triac or relay) and includes high performance suppression.



c. Fan Kit (1020 only)

Extends the thermal capacity of an EUM. Mounts between motor and EUM, includes shaft, fan, guard and hardware. Available in standard black coating or food grade approved white coating.



d. Mounting Brackets

Two styles of mounting brackets are available for simplified installation. The base mount is used with the 2030 configuration. A motor mount is also available and provides sturdy support for a 1020 or 1040 combination with motor.



4. Select Control

Warner Electric manufactures clutch/brake controls to meet several system functions including:

- On/Off
- Torque adjust
- Over excitation
- Position loop

Many requirements beyond function can impact control selection. See the Controls Section on page 141 for complete information.

Selection and Ordering Information

Part Numbers

Totally Enclosed EUM	Voltage DC	Part No.
1020 Configuration		
	6	5370-273-058
EUM-50-1020	24	5370-273-059
	90	5370-273-057
EUM-100-1020	6	5370-273-092
	24	5370-273-093
	90	5370-273-091
EUM-180-1020	6	5370-273-066
	24	5370-273-067
	90	5370-273-065
EUM-210-1020	6	5371-273-028
	24	5371-273-029
	90	5371-273-027
EUM-215-1020	6	5371-273-082
	24	5371-273-083
	90	5371-273-084
1040 Configuration		
EUM-50-1040	90	5370-271-050
EUM-180-1040	90	5370-271-051
EUM-210-1040	90	5371-271-024
2030 Configuration		
EUM-50-2030	6	5370-273-062
	24	5370-273-063
	90	5370-273-061
EUM-180-2030	6	5370-273-070
	24	5370-273-071
	90	5370-273-069
EUM-210-2030	6	5371-273-032
	24	5371-273-033
	90	5371-273-031

Washdown EUM-W	Voltage DC	Part No.
1020 Configuration		
	6	5370-273-100
EUM-50-1020W	24	5370-273-101
	90	5370-273-099
EUM-100-1020W	6	5370-273-108
	24	5370-273-109
	90	5370-273-107
EUM-180-1020W	6	5370-273-116
	24	5370-273-117
	90	5370-273-115
EUM-210-1020W	6	5371-273-056
	24	5371-273-057
	90	5371-273-055
EUM-215-1020W	6	5371-273-086
	24	5371-273-087
	90	5371-273-088
2030 Configuration		
	6	5370-273-104
EUM-50-2030W	24	5370-273-105
	90	5370-273-103
EUM-180-2030W	6	5370-273-120
	24	5370-273-121
	90	5370-273-119
EUM-210-2030W	6	5371-273-060
	24	5371-273-061
	90	5371-273-059

Accessories

Option	Size	Enclosed UniModule	Washdown UniModule
Conduit box	All sizes	5370-101-042	5370-101-045
Control	CBC-150-1	6004-448-001	6004-448-001
	CBC-150-2	6004-448-002	6004-448-002
Base Mount Kits for 2030	Size 50/180*	5370-101-002	5370-101-047
	Size 210	5371-101-001	5371-101-025
Motor Mount Kits for 1020, 1040	Size 50/100/180*	5370-101-012	5370-101-049
	Size 210/215	5371-101-012	5371-101-026
Fan Kits for 1020	Size 50/100	5370-101-055	5370-101-060
	Size 180	5370-101-054	5370-101-061
	Size 210	5371-101-029	5371-101-033

* Because of diameter limitations, EUM bases are available in 4.5" center height (143/145TC) only.

How to Order

Motor or Reducer Mounted

Simply combine the size number with the configuration of the required UniModule. Specify voltage. See chart for specific part numbers. Order optional conduit box if desired.

Example

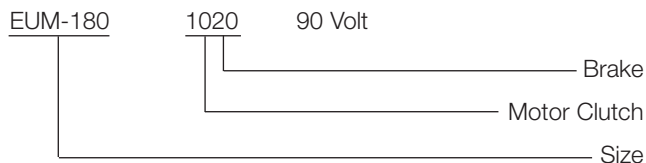

Base Mounted

Simply combine the size number with the configuration of the required UniModule. Specify voltage. See chart for specific part numbers. Order optional conduit box if desired.

Example

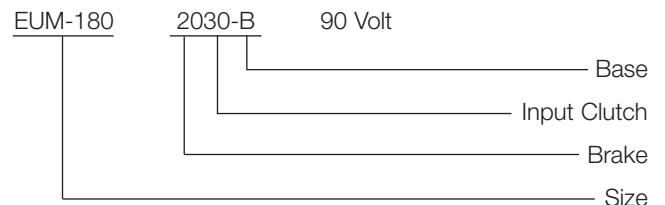

EUM-1020 Clutch/Brake Combination EUM-W-1020 Clutch/Brake Combination

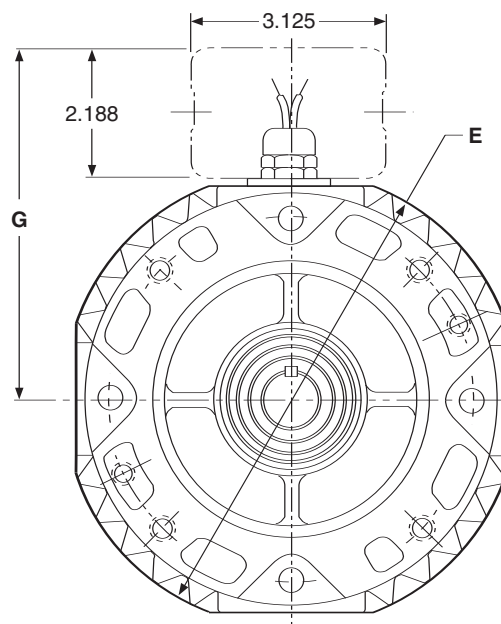
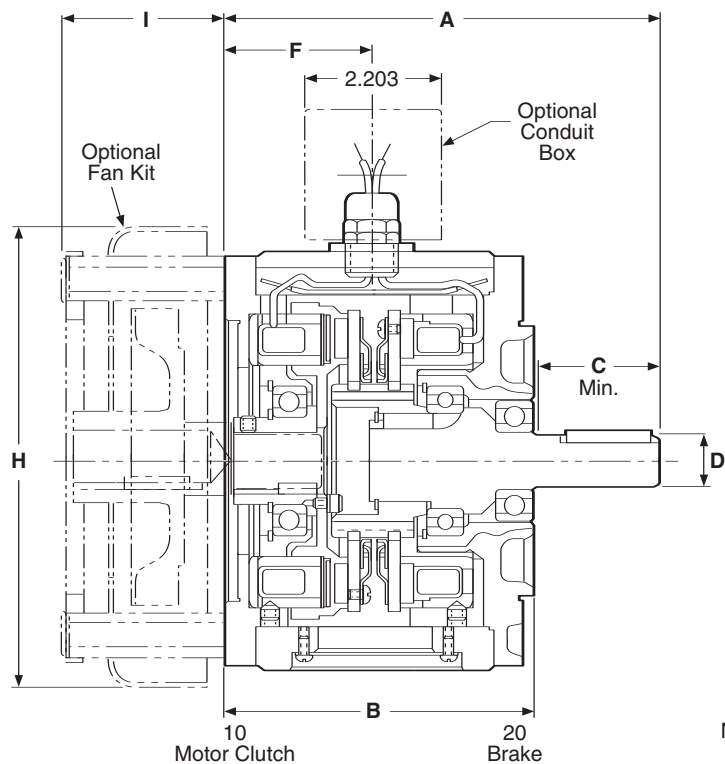

Note: Washdown Unimodules (EUM-W) do not have a finned housing.

All dimensions are nominal, unless otherwise noted.

Size	A	B	C	D	E		F	G	H	I
					EUM	EUM-W				
50/100	6.750	4.844	1.813	.625	7.270	6.915	2.427	5.936	7.687	2.430
180	6.828	4.844	1.890	.875	7.270	6.915	2.427	5.936	7.687	2.430
210	8.891	5.922	2.500	1.125	10.000	10.00	3.053	7.146	10.187	3.375
215	9.391	5.922	3.000	1.375	10.000	10.00	3.053	7.146	10.187	3.375

Specifications

UniModule Size	Shaft Dia.	Horsepower	Static Torque lb. ft.	CPM @1750 RPM	Max. RPM	Voltage DC	NEMA Frame Size
EUM50	.625	1/4-3/4	16	125	3600	6, 24 or 90	56C/48Y
EUM100	.625	1	30	90	3600	6, 24 or 90	56C/48Y
EUM180	.875	1-2	30	90	3600	6, 24 or 90	182C/143TC 184C/145TC
EUM210	1.125	3-5	95	37	3600	6, 24 or 90	213/182TC 215C/184TC
EUM215	1.375	7-1/2	95	37	3600	6, 24 or 90	213TC/215TC

For NEMA standard frame sizes, see page 137.

EUM-1040 Clutch Combination

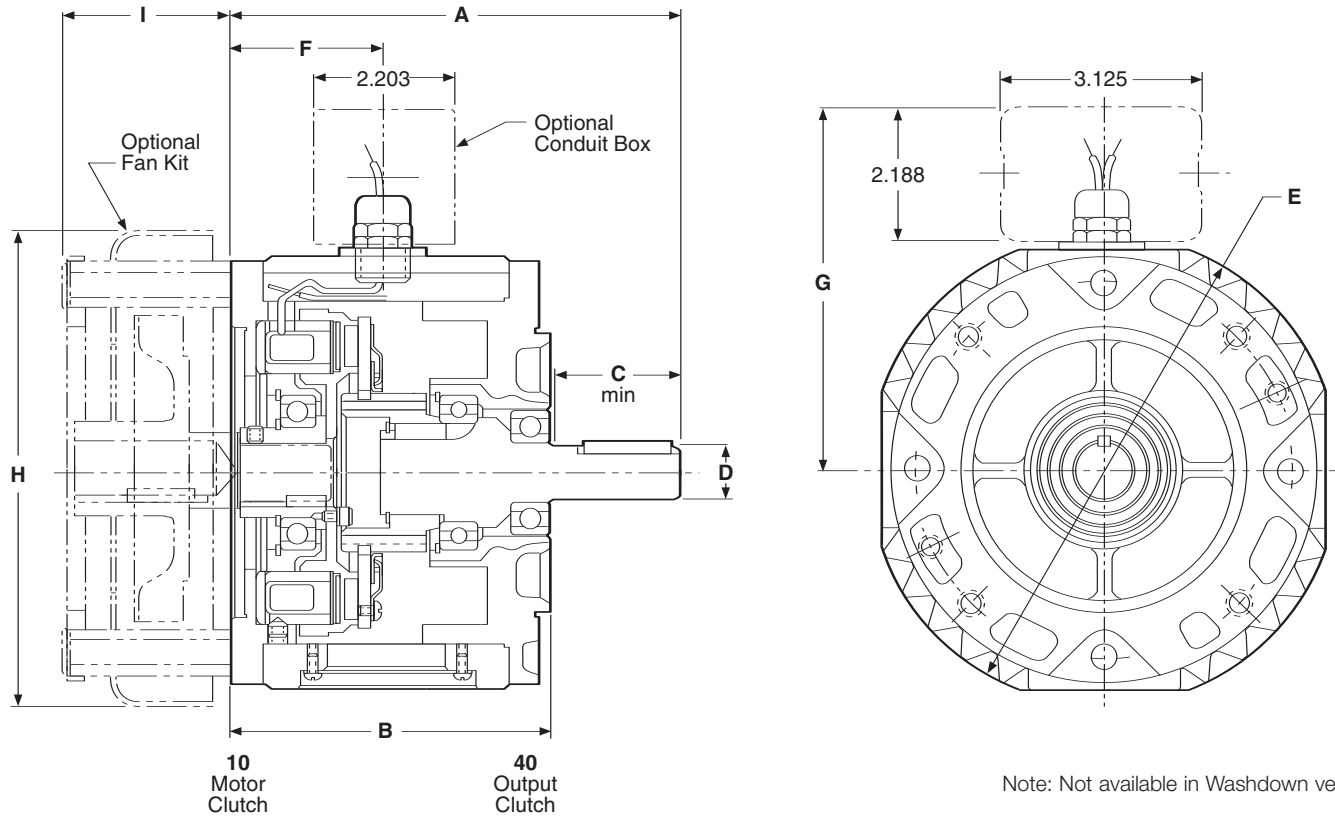

All dimensions are nominal, unless otherwise noted.

Size	A	B	C	D	E	F	G	H	I
50/100	6.750	4.844	1.813	.625	7.270	2.427	5.936	7.687	2.430
180	6.828	4.844	1.890	.875	7.270	2.427	5.936	7.687	2.430
210	8.891	5.922	2.500	1.125	10.000	3.053	7.146	10.187	3.375

Specifications

UniModule Size	Shaft Dia.	Horsepower	Static Torque lb. ft.	CPM @1750 RPM	Max. RPM	Voltage DC	NEMA Frame Size
EUM50	.625	1/4-3/4	16	125	3600	6, 24 or 90	56C/48Y
EUM100	.625	1	30	175	3600	6, 24 or 90	56C/48Y
EUM180	.875	1-2	30	175	3600	6, 24 or 90	182C/143TC 184C/145TC
EUM210	1.125	3-5	95	32	3600	6, 24 or 90	213/182TC 215C/184TC

For NEMA standard frame sizes, see page 137.

EUM-2030 Clutch/Brake Combination–Base Mounted EUM-W-2030 Clutch/Brake Combination–Base Mounted

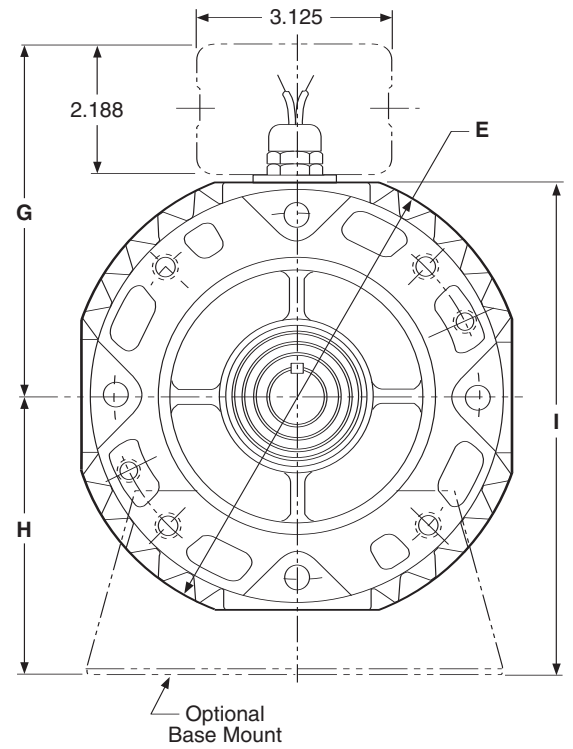
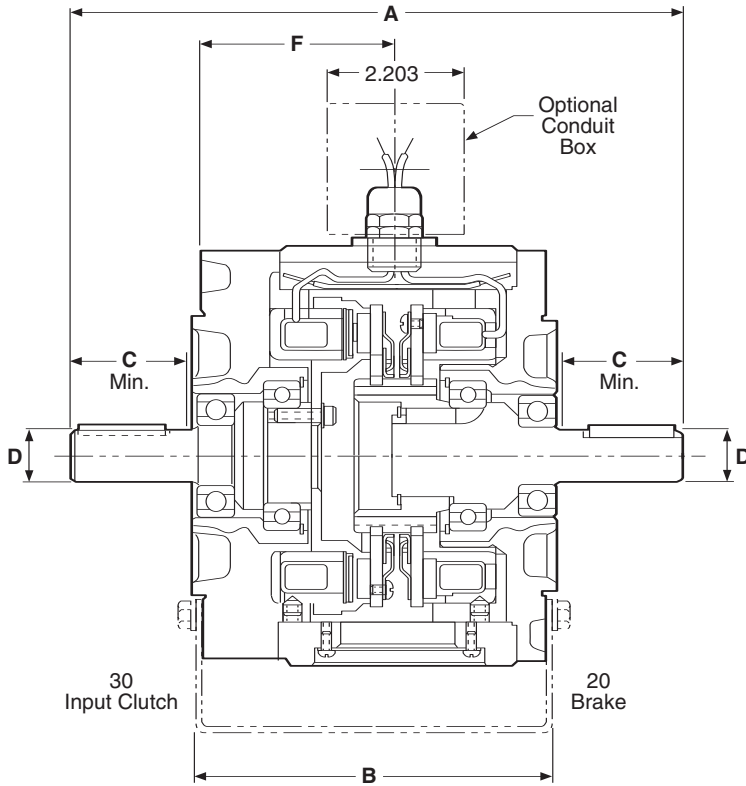

Note: Washdown UniModules (EUM-W) do not have a finned housing.

All dimensions are nominal, unless otherwise noted.

Size	A	B	C	D	E		F	G	H	I
					EUM	EUM-W				
50	9.516	5.672	1.813	.625	7.270	6.915	3.164	5.936	3.670	7.119
180	9.516	5.672	1.890	.875	7.270	6.915	3.164	5.936	4.484	8.119
210	12.969	8.260	2.500	1.125	10.000	10.00	4.514	7.146	5.234	10.234

Specifications

UniModule Size	Shaft Dia.	Horsepower	Static Torque lb. ft.	CPM @1750 RPM	Max. RPM	Voltage DC	NEMA Frame Size
EUM50	5/8"	1/4-3/4	16	125	3600	6, 24 or 90	56C/48Y
EUM100	5/8"	1	30	175	3600	6, 24 or 90	56C/48Y
EUM180	7/8"	1-2	30	175	3600	6, 24 or 90	182C/143TC 184C/145TC
EUM210	1-1/8"	3-5	95	32	3600	6, 24 or 90	213/182TC 215C/184TC

For NEMA standard frame sizes, see page 137.

Module Options

Warner Electric Enclosed UniModules can be fitted with several accessories to extend their capacity and ease of mounting.

Conduit Box

NEMA 4 and UL listed, available in standard and washdown versions.



Integral Control

The CBC-150 dual channel control fits into the cover of the conduit box. It is suitable for AC side switching (triac or relay) and includes high performance suppression.



Fan Kit (UM and EUM 1020 only)

Extends the thermal capacity of an EUM. Mounts between motor and EUM, includes shaft, fan, guard and hardware. Available in standard black coating or food grade approved white coating.



Mounting Brackets

Two styles of mounting brackets are available for simplified installation. The base mount is used with the 2030 configuration. A motor mount is also available and provides sturdy support for a 1020 or 1040 combination with motor.

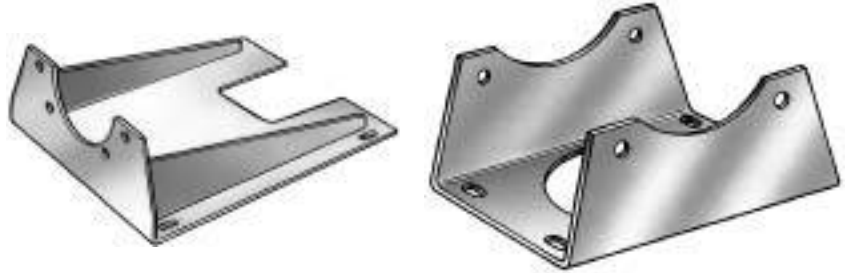

(Optional)

Motor Mount (M)

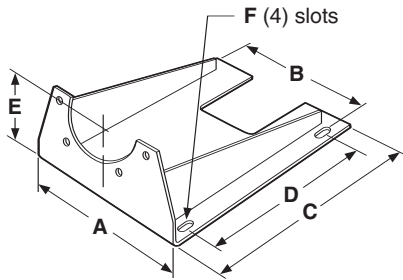

For use with 1020, 1040, 20, 20 FBB and 1020 FBC Combinations.

Size	A	B	C	D	E	F	Part No.
50/100	9.25	8.25	11.00	8.000	3.50	.797 x .406	5370-101-010
180	9.25	8.25	11.00	8.000	4.50	.797 x .406	5370-101-012/5370-101-047
210/215	11.50	10.50	12.00	9.000	5.25	.750 x .406	5371-101-012/5371-101-025

Base (B)

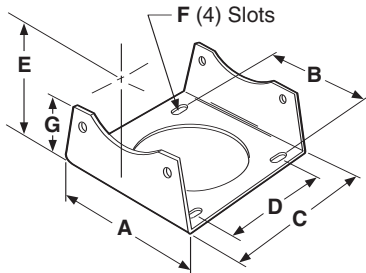

For use with 2030 and 3040 units.

Size	A	B	C	D	E	F	G	Part No.
50/100	6.000	5.000	5.672	4.000	3.500	.750 X .406	2.000	5370-101-004
180	6.625	5.000	5.672	4.000	4.500	.750 X .406	3.000	5370-101-002/5370-101-049
210/215	9.000	7.750	8.203	6.000	5.250	.750 X .531	3.385	5371-101-001/5371-101-026

Distribuidor Autorizado e Importador - Arten Freios e Embreagens Ltda.

Fone: (11) 5594-8333 • Fax (11) 5589-2422 - arten@arten.com.br • www.arten.com.br