

Warner Electric's electronic controls are designed to provide simple setup and maximum performance when used with electric clutches and brakes. Our controls offer a range of functions from on-off to torque control to over-excitation.

Selection

Many parameters beyond function can impact control selection. Warner Electric produces a variety of control options to suit numerous application requirements. Control selection parameters include:

- Mounting Location – Panel or conduit box mounting
- Switching – Relay switching of A.C. or D.C. lines or solid state switching
- Output Voltage – Controls are available for 6, 24 and 90 VDC clutch/brake coils
- Input Voltage – Controls with input power transformers are available for connection to high voltage mains.

If your application requires something special, please call us. We will be happy to provide solutions.

Clutch and Brake Controls 142

On-Off Controls

CBC-100	144
CBC-150	144
CBC-160	145
CBC-801	146
CBC-802	147
CBC-400	148
CBC-450	149

Adjustable Torque Controls

MCS-103-1	150
MCS-805-1	151
MCS-805-2	151
CBC-200	152
CBC-300	152
CBC-500	153
CBC-550	154
CBC-1825R	156

Overexcitation Controls

CBC-700	158
CBC-750	160

Closed Loop Position Control

CBC-1000	162
----------------	-----

Appendix 164

Questions & Answers 165

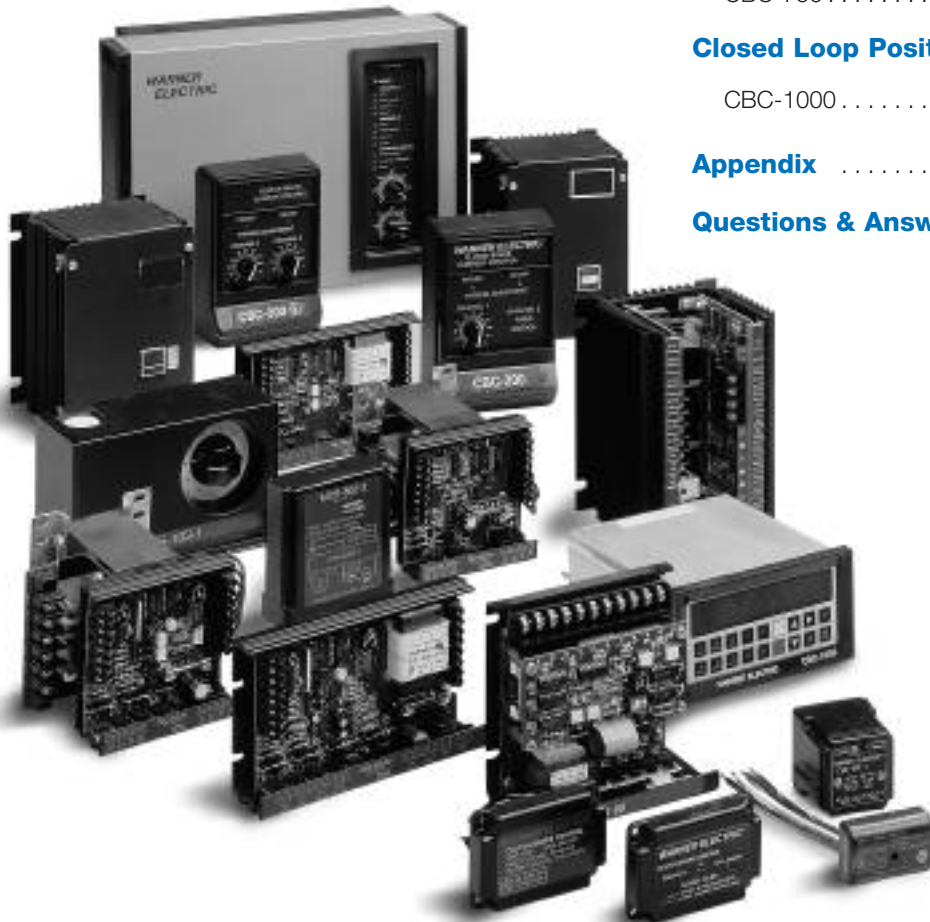

Clutch and Brake Controls

Functions

On-Off (Basic start-stop)

Many applications are controlled by energizing the clutches and brakes with their rated D.C. voltages. Warner Electric controls are available with various mounting, input voltage and switching options.

Adjustable Torque

(Soft start-stop)

The torque transmitted by a clutch or brake is proportional to the coil current. Warner Electric offers several products that provide torque control for smooth and repeatable starts and stops.

Adjustable Accel-Decel

(Soft start-stop with full torque)

Warner Electric offers a control that allows for adjustment of the acceleration and deceleration time ramps to achieve a repeatable soft start or stop while still allowing for full torque.

Overexcitation

(Rapid cycling)

The clutch/brake speed of response can be increased for improved accuracy and performance through overexcitation, which is the application of a short high voltage pulse to provide nearly instantaneous torque.

Position Loop

(Programmable cycling)

Warner Electric's CBC-1000 position loop control system offers servo system performance with electric clutch/brake economy in high accuracy indexing applications. The unique error correction capability of the CBC-1000 to achieve repeatability and accuracy makes this an ideal control for many applications.

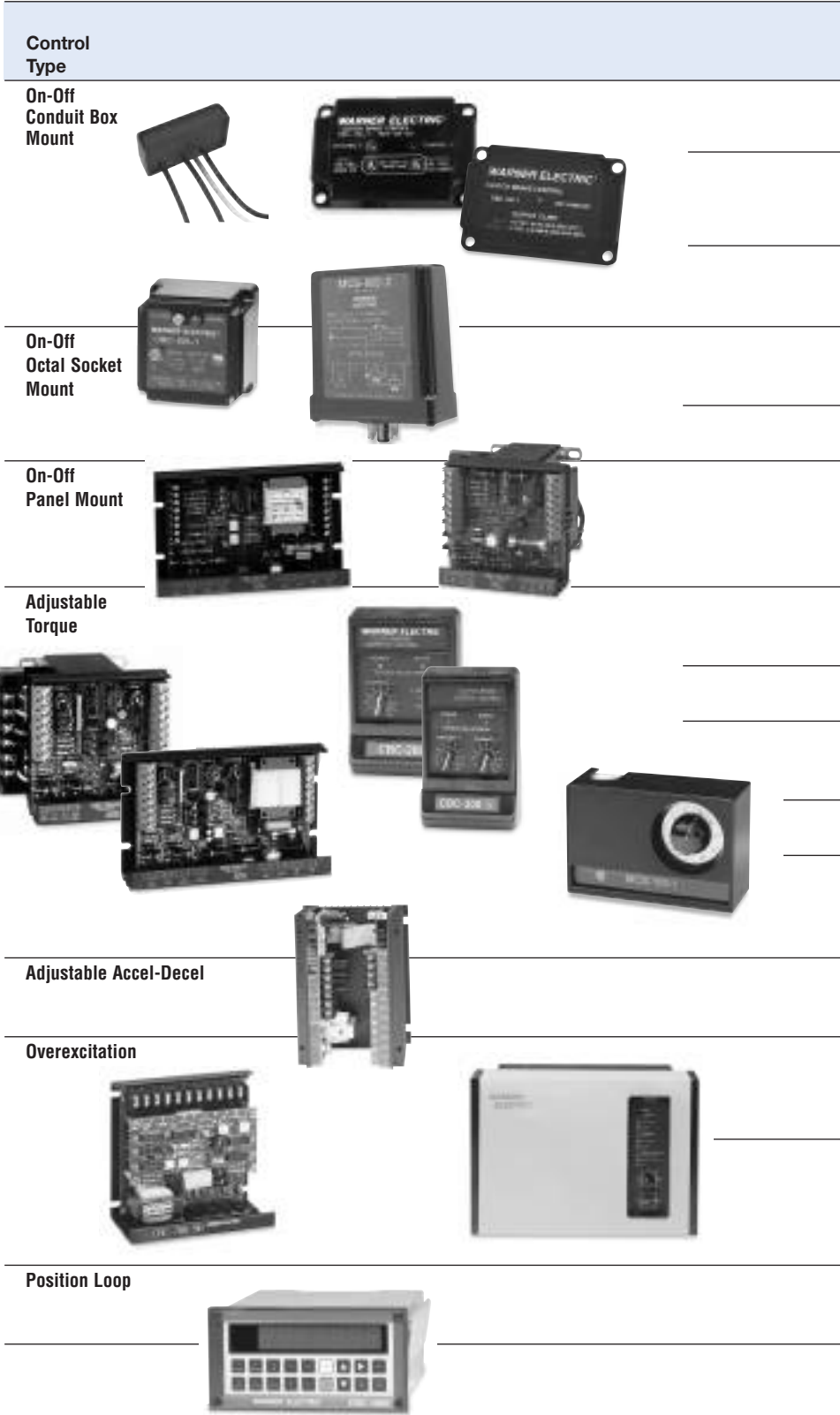

Clutch and Brake Controls

Model Number	No. of Channels	Torque Control Channels	A.C. Input Voltages	D.C. Output Voltages	Over-Excitation	Customer Supplied Switching Options	Description	Page Number
CBC-100-1 CBC-100-2	1 1	No No	120 220/240	90	No	Relay A.C.	Single channel control to mount inside standard conduit box	144
CBC-150-1 CBC-150-2	2 2	No No	120 220/240	90	No	Relay A.C.	Dual channel control for clutch/brake to mount inside module conduit box	144
CBC-160-1 CBC-160-2	1 1	1 1	120 220/240	90	No	Relay A.C.	Single channel control with torque adjust for module electrically released brakes	145
CBC-801-1 CBC-801-2	2 2	No No	120 220/240	90	No	Relay D.C.	Dual channel control for 2 clutches and/or brakes	146
CBC-802	2	No	120	90	No	Transistor or Relay D.C.	Dual channel control with transistor switching	147
CBC-400-90 CBC-400-24 CBC-450-90 CBC-450-24	2 2 2 2	No No No No	120 24-30 120/220/240/380/480 120/220/240/380/480	90 24 90 24	No No No No	Transistor or Relay D.C.	Dual channel control for use with 2 clutches and/or brakes; Emergency stop input and AUX power supply	148- 149
MCS-103-1	2	1	120	90	No	Relay D.C.	Dual channel control with torque adjust for one channel	150
MCS-805-1 MCS-805-2	1 1	1 1	120/240	35-75	No	Relay D.C.	Single adjustable channel control for use with ER-1225 brake.	151
CBC-200	2	1	120	90	No	Transistor or Relay D.C.	Dual channel control with one adjustable current and one fixed voltage	152
CBC-300	2	2	120	90	No	Transistor or Relay D.C.	Dual channel adjustable current control	152
CBC-500-90 CBC-500-24 CBC-550-90 CBC-550-24	2 2 2 2	2 2 2 2	120 24-30 120/220/240/380/480 120/220/240/380/480	90 24 90 24	No No No No	Transistor or Relay D.C.	Dual channel control for two clutches and/or brakes with two torque adjust channels; Emergency stop input	153- 155
CBC-1825-R	2	2	120	90	No	Transistor or Relay D.C.	Dual channel adjustable time ramp with short circuit protection	156
CBC-700-90 CBC-700-24	2 2	No No	120 24-28	90 24	Yes	Transistor or Relay D.C.	Dual channel compact overexcitation control for 24 or 90 volt clutches and brakes	158
CBC-750-6-24-90	2	2	120/220/240	6,24,90	Yes	Transistor, Relay D.C. or Triac A.C.	Dual channel full function overexcitation control; provides input/output logic, torque adjustable current and remote inputs	160
CBC-1000	2	N.A.	120/230	N.A.	N.A.	N.A.	Error correction control to be used with one of the above	162

Integral/Conduit Box Mounted Controls

The CBC-100 and CBC-150 series are UL listed, conduit box mounted controls for 90 volt clutches and brakes. Models are available for either 120 VAC or 220/240 VAC input.



CBC-100 series Single unit capacity

The CBC-100 mounts inside a standard Warner Electric conduit box and includes rectification and suppression circuits.

- CE
- UL and UL
- SF
- Compact
- Single channel
- Mounts inside conduit box



CBC-150 series Dual channel capacity

The CBC-150 replaces the cover on the standard module conduit box (part no. 5370-101-042). Provides rectification and suppression for two devices. Green LED indicates power to clutch. Red LED indicates power to brake.

- CE
- UL and UL
- Dual channel
- Replaces the cover on the module conduit box

Specifications

	CBC-100-1	CBC-100-2	CBC-150-1	CBC-150-2
Part No.	6003-448-101	6003-448-103	6004-448-001	6004-448-002
Input	120 VAC 50/60 Hz	220/240 VAC 50/60 Hz	120 VAC 50/60 Hz	220/240 VAC 50/60 Hz
Output	90 VDC full wave rectified .8 Amp max.	90 VDC half wave .8 Amp	90 VDC full wave rectified Dual .8 Amp	90 VDC half wave rectified Dual .8 Amp
Ambient Temperatures	-20° to 113°F (-29° to 45°C)			
Switching	External to control, accomplished on A.C. line using relay or triac.			
	SPST	SPST	SPDT	SPDT
Solid State (maximum leakage current <2 mA)	140 VAC, 1 Amp min.	280 VAC, 1 Amp min.	140 VAC, 2 Amp min.	280 VAC, 2 Amp min.
Electro- mechanical	120 VAC, 1 Amp min.	240 VAC, 1 Amp min.	120 VAC, 1 Amp min.	240 VAC, 1 Amp min.

Connection diagrams

CBC-100-1, -2

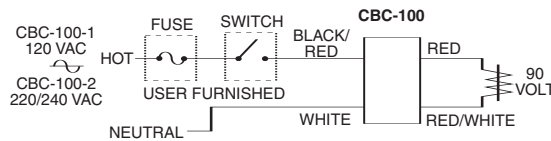

Dimensions

CBC-100-1, -2

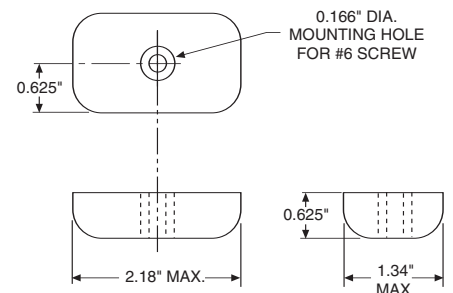

CBC-150-1, -2

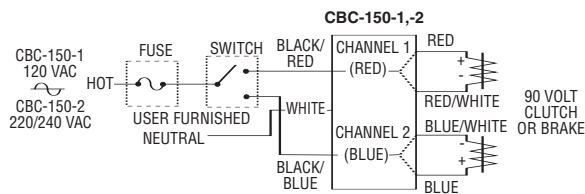

CBC-150-1, -2

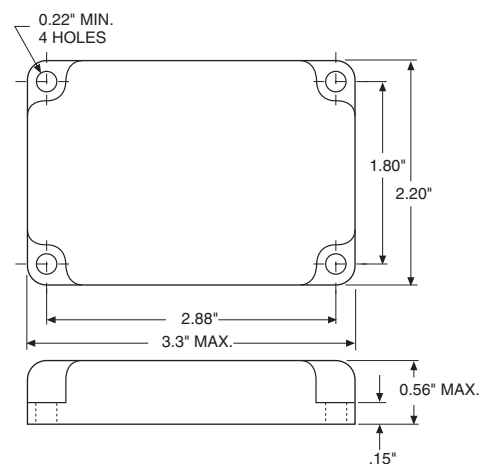

All dimensions nominal unless otherwise specified.

Integral/Electrically Released Motor Brake Controls

CBC-160

The CBC-160 series clutch/brake controls provide a single 90 VDC adjustable output for use with any clutch/brake unit. The adjustable output will provide consistent and repeatable release for Warner Electric's 90 VDC permanent magnet electrically released brakes. The CBC-160 mounts as the cover on the standard module conduit box (part number: 5370-101-042).



The 160-1 accommodates 120 volts A.C. motors.



- Adjustable 30-100 VDC
- LED indicator
- 120 volt A.C. input

The power to the 160-2 control can come from either a 230 volt or 460 volt A.C. motor. Customer-provided switching is accomplished through the motor starter on the A.C. input. This allows convenient retrofit of spring-set style motor brakes and inexpensive installation of new applications.



- Adjustable 30-100 VDC
- Power from motor
- Easy retrofit
- 230/460 motors

Dimensions

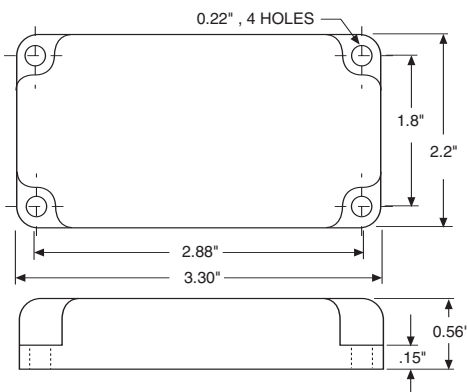

All dimensions nominal unless otherwise specified.

Specifications

	CBC-160-1	CBC-160-2
Part No.	6013-448-001	6013-448-002
Input	120 VAC, 50/60 Hz	220/240 VAC, 60 Hz, 1 Phase, 100 VA max.
Status Indicator	Red LED indicates power to the brake	—
Output	Single Channel, 30-100 VDC half-wave rectified nominal, 0.8 Amps maximum	
Ambient Temperatures	0° to 122°F (-18° to 50°C)	
Switching	Accomplished through motor starter or on A.C. line using relay or triac	

Connection Diagram

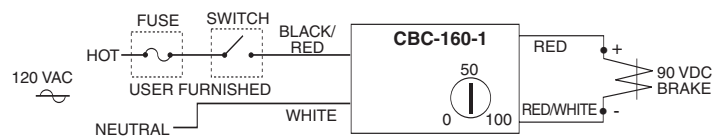

WYE Connected Motor

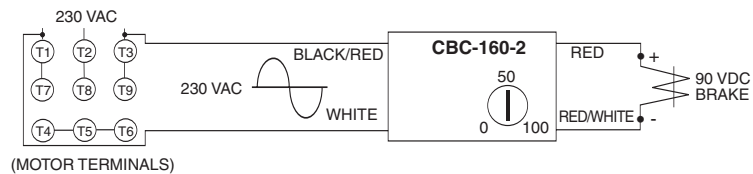
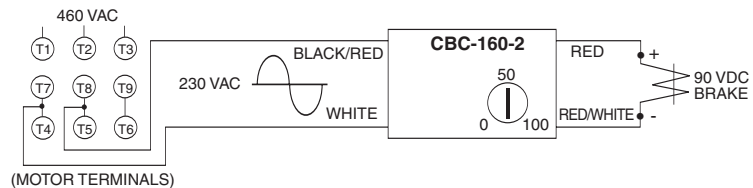

DELTA Connected Motor

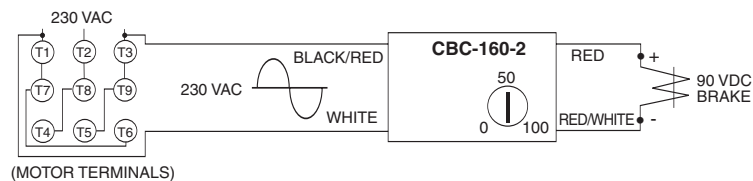
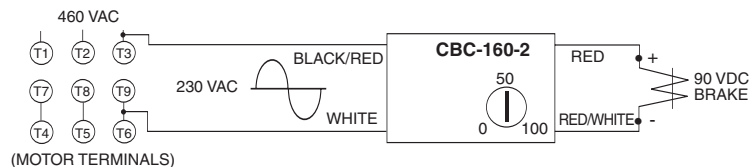

Plug-in Octal Socket Power Supplies

The CBC-801 is a basic on-off power supply that provides full voltage to a 90 volt clutch or brake and is activated by an external switch. This type of power supply is sufficient for many clutch/brake applications.

CBC-801 series Multi-unit capacity

The CBC-801 is a plug-in power supply which is used with an octal socket. The wiring connections are made at the socket. The CBC-801 will operate two units separately—or simultaneously. Octal socket is purchased separately.



- For basic on-off operation
- Wiring connections made at octal socket
- Arc suppression circuitry extends switch life
- Fused for overload protection
- LED output indicators
- DIN rail mountable



Specifications

	CBC-801-1	CBC-801-2
Part No.	6001-448-004	6001-448-006
Input Voltage	120 VAC, 50/60 Hz	220/240 VAC, 50/60 Hz
Output	90 VDC, 1.25 A max.	
Circuit Protection	Fused 1.6 Amp, 250 V fast-blo	
Ambient Temperature	-23° to 116°F (-31° to 47°C)	
Max. Cycle Rate	Limited by the clutch or brake, variable with application	
Switching	Single pole, double throw Minimum contact rating: 10 Amp, 28 VDC resistive or 10 Amp, 120 VAC inductive	
Status Indicator	Red LED indicates brake is energized, Green LED indicates clutch is energized	
Mounting	Two versions of octal socket are available: 6001-101-001 foot mount 6001-101-002 DIN rail mount	

Dimensions

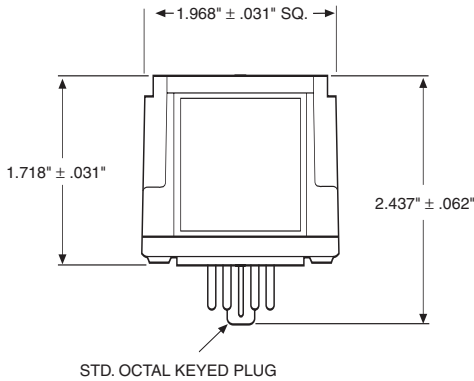

OCTAL SOCKET

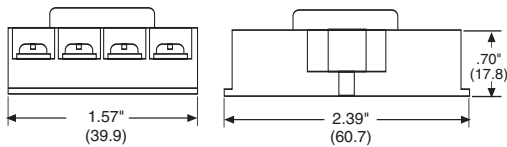

DIN RAIL MOUNT SOCKET

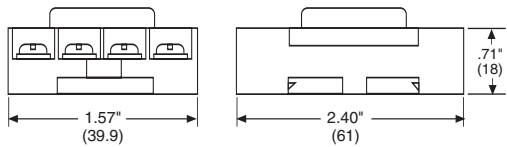

All dimensions nominal unless otherwise specified.

Connection Diagram

Connection diagram for operating clutch/brake separately.

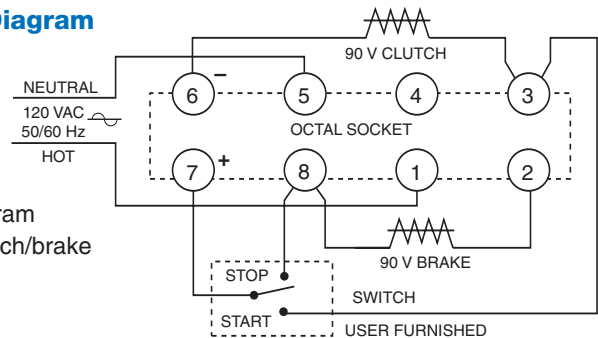

Connection diagram for operating clutch/brake simultaneously.

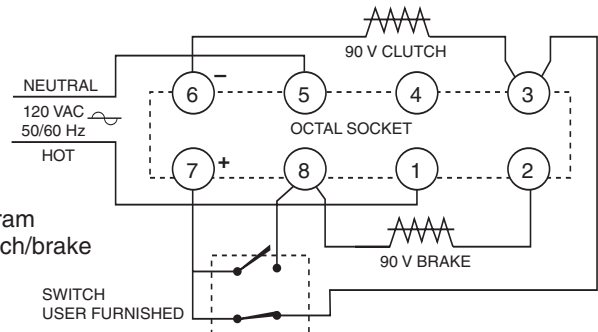



CBC-802 PLC compatible

The CBC-802 is a power supply with solid state circuits for load switching. A brake and clutch may be operated separately—or, two brakes or two clutches, one unit on at a time. The CBC-802 mounts on an octal socket (purchased separately), and the wiring connections are made at the socket terminals. Octal socket sold separately, refer to mounting specifications for part number.

-  Plug-in power supply with solid state switching circuits—increases switch service life
- Adjustable time delay for controlling clutch/brake overlap
- Internally fused for overload protection
- DIN rail mountable
- LED output indicators

Dimensions

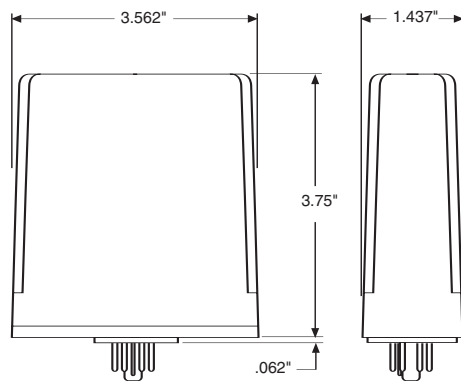

STD. OCTAL KEYED PLUG

All dimensions nominal unless otherwise specified.

Specifications

CBC-802	
Part No.	6002-448-001
Input	120 VAC, 50/60 Hz
Output	90 VDC, 0.5 A max.
Status Indicator	Red LED indicates brake energized. Green LED indicates clutch energized.
Circuit Protection	Fused 0.5 Amps, 250 V
Ambient Temperature	-20° to 113°F (-29° to 45°C)
Leakage Current	500 uA max. for solid state switches
Max. Cycle Rate	Limited by the clutch or brake, variable with application
Switching	Momentary contact, maintained contact, or solid state open collector logic Minimum contact rating 20 VDC resistive, 0.01 Amps Minimum input pulse—1 millisecond
Adjustments	Externally adjusted potentiometer sets overlap between clutch and brake from 0 to 130 MS.
Mounting:	Two versions of octal socket are available: 6001-101-001 foot mount 6001-101-002 DIN rail mount

Connection Diagram

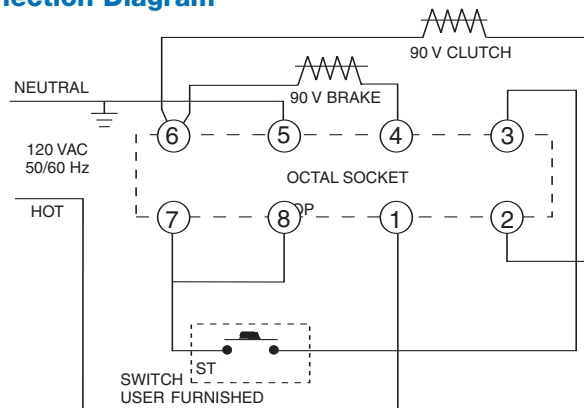

Panel Mounted Control



Specifications

	CBC-400-90	CBC-400-24
Part No.	6006-448-003	6006-448-002
Input Voltage	120 VAC	24-30 VAC
Output Voltage	90 VDC	24 VDC
Output Current	1 Amp/Channel 2 Amps Total	5 Amps/Channel 5 Amps Total
Auxiliary Supply	12 VDC 250 mA	
Circuit Protection	Fused 2.5 Amp, 250 V fast-blo	Fused 6.3 Amp, 250 V fast-blo
Ambient Temperature	+32° to 122°F (0° to 50°C)	
Status Indicators	Red LED indicates channel is energized.	
Adjustments	Jumper for single or dual operation. See appendix for explanation.	
Inputs	3 Optically isolated, 10-30 VDC, 3-9 mA for Channel 1, Channel 2 and Channel 2 override (applies full voltage to channel 1 output).	

Connection Diagram

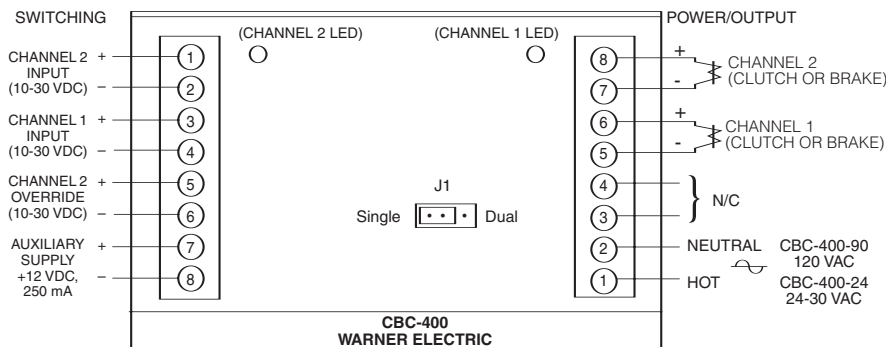

All dimensions nominal unless otherwise specified.

CBC-400 series Dual channel controls

The CBC-400 series is a basic on-off control which supplies 24 or 90 VDC for electric clutch/brake operation. They offer optically isolated switching inputs for start, stop, and emergency stop (E-stop). These controls can be set up to operate the two outputs alternately (single) or simultaneously (dual). Refer to the Appendix for additional setup and switching information.



- 24 or 90 Volt DC output
- Auxiliary 12V supply
- Fast coil suppression
- Single or dual channel operation
- Optically isolated input switching

Enclosure (Optional)



- Lift off hinge
- Quick-release latches
- Conforms to NEMA Type 13
- European Standard IEC 529, IP65

Part No. 6042-101-004

Size 8"H x 6"W x 4"D
(203.2 x 152.4 x 101.6 mm)

Dimensions

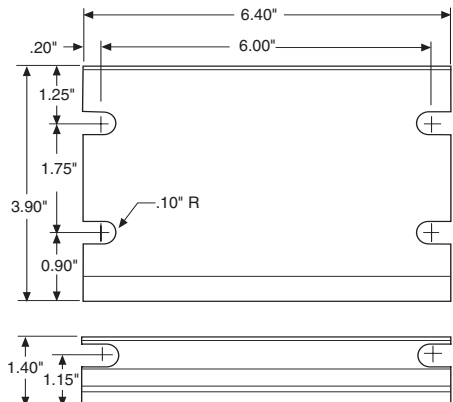

CBC-450 series Dual channel control with transformer for variable input voltage

The CBC-450 series is a basic on-off control which supplies 24 or 90 VDC for electric clutch/brake operation. They offer optically isolated switching inputs for start, stop, and emergency stop (E-stop). These controls can be set up to operate the two outputs, alternately (single) or simultaneously (dual). Refer to the Appendix for additional setup and switching information. The CBC-450 series has a power transformer which will operate with a 120, 220, 240, 380 or 480 VAC input.



Enclosure (Optional)



- Lift off hinge
- Quick-release latches
- Conforms to NEMA Type 13
- European Standard IEC 529, IP65



- 24 or 90 Volt DC output
- Auxiliary 12V supply

- Fast coil suppression
- Single or dual channel operation
- Optically isolated switching

Part No.	6006-101-007
Size	6"H x 6"W x 6"D (152.4 x 152.4 x 152.4 mm)

Specifications

	CBC-450-90	CBC-450-24
Part No.	6006-448-006	6006-448-005
Input Voltage	120/220/240/380/480 VAC	
Output Voltage	90 VDC	24 VDC
Output Current	1 Amp/Channel 1.2 Amps Total	4 Amps/Channel 4 Amps Total
Auxiliary Supply	12 VDC 250 mA	
Circuit Protection	Fused 1.5 Amp	Fused 5 Amp
Ambient Temperature	+32° to 122°F (0° to 50°C)	
Status Indicators	Red LED indicates channel is energized.	
Adjustments	Jumper for single or dual operation. See appendix for explanation.	
Inputs	3 Optically isolated, 10-30 VDC, 3-9 mA for Channel 1, Channel 2 and Channel 2 override (E-stop).	

Dimensions

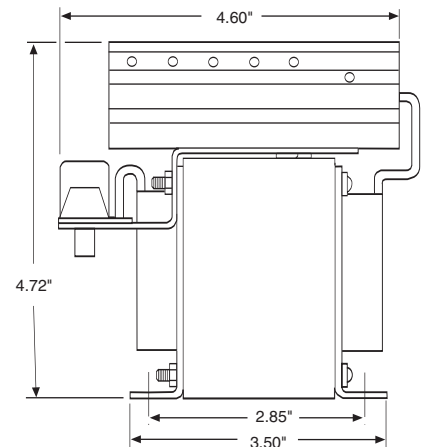
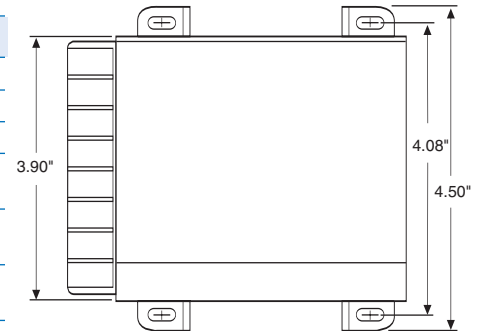

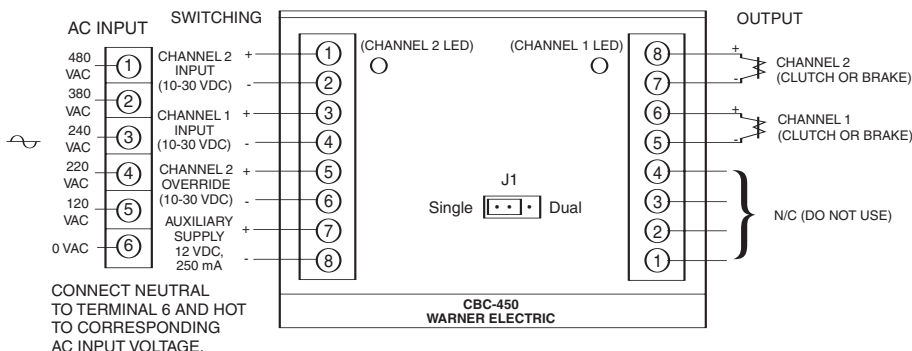

Connection Diagram



All dimensions nominal unless otherwise specified.

Adjustable Torque Control

The MCS-103-1 is an enclosed control complete with a cover and mounting provisions. A brake and clutch may be operated separately with this control – or up to four units, two at a time. The external wiring is connected to the terminal strip located behind the cover.

- 
- 
- Can be used with electrically released brakes

- Torque control for one 90 VDC clutch or brake
- Operates up to four units, two on at a time
- Easy-to-install. Compact. 120 VAC input
- Convenient terminal strip behind an easy-to-remove cover



Dimensions

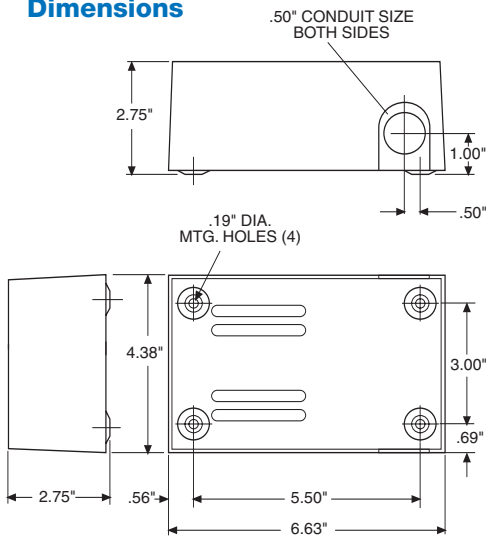

All dimensions nominal unless otherwise specified.

Specifications

MCS-103-1	
Part No.	6010-448-002
Input	120 VAC, 50/60 Hz
Output	1.25 Amp 90 V full wave rectified for one unit and adjustable from 0-90 volts full wave rectified for second unit
Circuit Protection	Fused 1.5 Amp, 250 V
Ambient Temperature	-20° to 113°F (-29° to 45°C)
Maximum Cycle Rate	Limited by the clutch or brake and will vary with application.
Mounting	Mounting centers 5-1/2" wide, 3" high. Knockouts for 1/2" conduit
External Switches (User furnished)	Double pole, double throw maintained contact. Minimum contact rating: 10 Amp, 28 VDC resistive or 10 Amp, 120 VAC inductive. Contact ratings given will operate all Warner Electric brake and clutch units. However, switches with ratings less than those given may be used with fractional horsepower units provided the rating is equal to or greater than the coil current.

Connection Diagrams

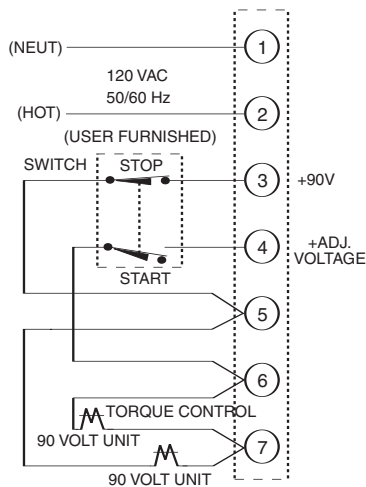

Normal Clutch/Brake Operation
(One unit on at a time)

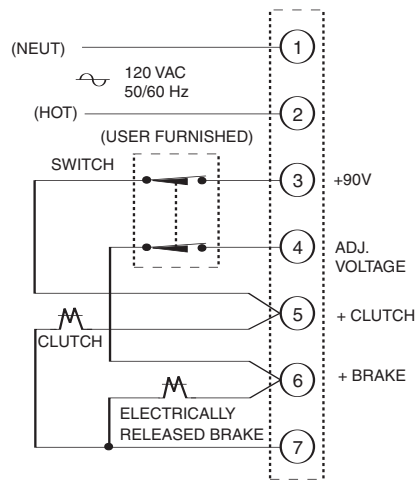

Clutch/Electrically Released
Brake Operation
(Both units on at a time)

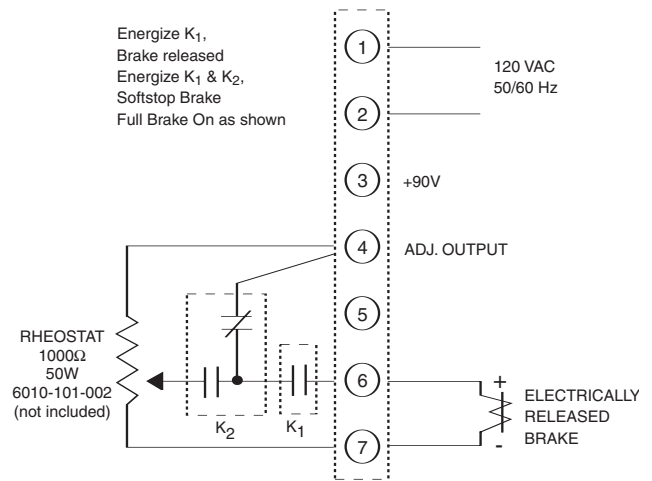

Soft Stop for
Electrically Released Brake

The DC voltage required to release the Warner Electric ER-1225 Brake is supplied by the MCS-805-1 or MCS-805-2 Power Supply. The correct brake release voltage—approximately 35-75 volts DC—is set by adjusting the power supply at the time of brake installation. Temperature compensating circuits provide proper operation over the entire operating range of 0°F to 150°F. Switching may be provided on either the AC or DC side of the power supply. The MCS-805-1 may be mounted on its back panel or on 1/2" conduit. The MCS-805-2 has a torque adjustment capability for soft stop applications. The MCS-805-2 requires two switching circuits when used for those applications requiring soft engagement.



Specifications

	MCS-805-1	MCS-805-2
Part No.	6090-448-006	6090-448-007
Input	115/230 VAC, 50/60 Hz ±10%	115/230 VAC, 50/60 Hz ±10%
Output	0.4 Amp, 35/75 VDC	0.4 Amp, 35/75 VDC
Ambient Temperature	-20° to 150°F (-29° to 65°C)	-20° to 150°F (-29° to 65°C)
Maximum Cycle Rate	Limited by the clutch or brake and will vary with application. Consult factory for specifics.	
External Switches (User furnished)	For DC switching: single pole, single throw. Minimum contact rating 1 amp, 120 volts DC resistive. For AC switching: single pole, single throw. Minimum contact rating 1 amp, 120 volts AC.	
Circuit Protection	.75 Amp 250V Slow Blow 3 AG	

Dimensions

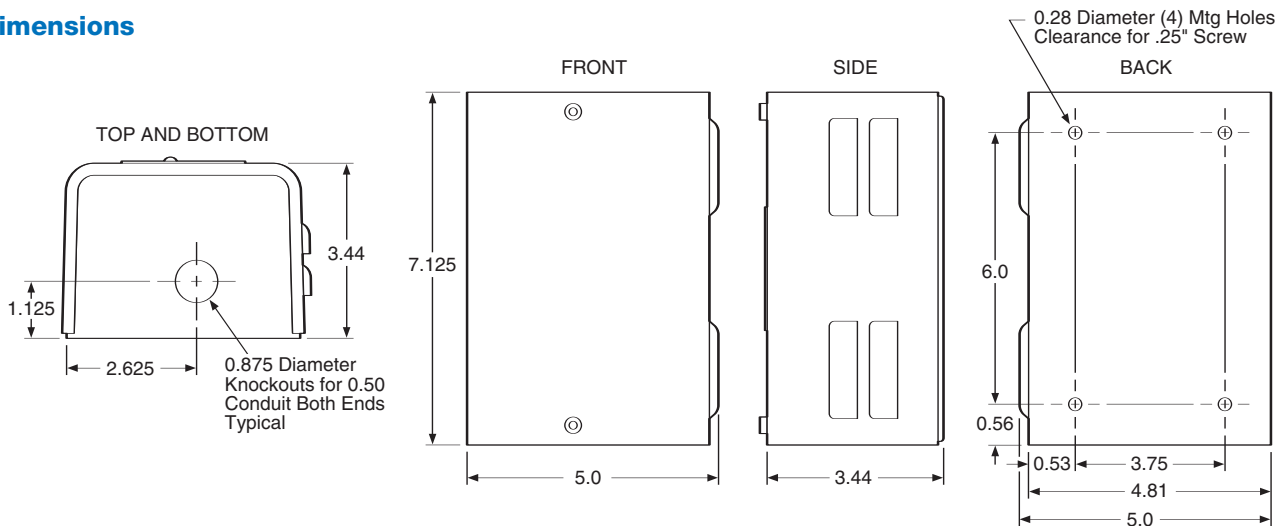

Connection Diagram

Connect the MCS-805-1 or MCS-805-2 Power Supply per the following diagram and instructions:

MCS 805-1

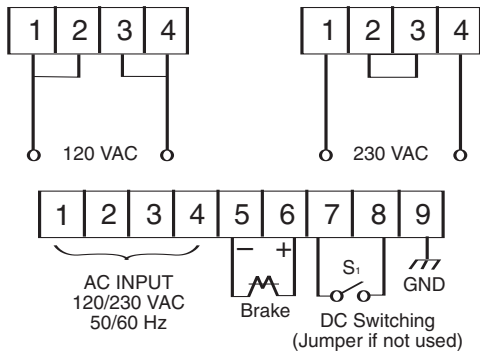

MCS 805-2

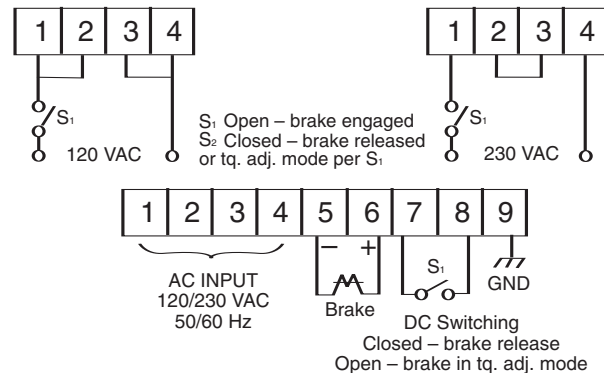

For AC switching, switch may be in series with input supply.
For DC switching, use terminals 7 and 8 as shown.
DO NOT put switch in series with load on terminals 5 and 6.



CBC-500 series Dual torque adjustable power supplies

The CBC-500 series is a dual channel adjustable voltage control with optically isolated input switching for 24 and 90 volt electric clutches and brakes. These controls can be set up to energize the two outputs alternately (single) or simultaneously (dual). Refer to the Appendix for additional setup and switching information.



- Dual adjustable channels
- Optically isolated input switching
- Single or dual channel operation
- Auxiliary 12V supply
- Can be used with electrically released brakes

Specifications

	CBC-500-90	CBC-500-24
Part No.	6024-448-003	6024-448-002
Input Voltage	120 VAC	24-30 VAC
Output Voltage	0-90 VDC	0-24 VDC
Output Current	1 Amp/Channel 2 Amps Total	5 Amps/Channel 5 Amps Total
Auxiliary Supply	12 VDC 250 mA	12 VDC 250 mA
Circuit Protection	Fused 2.5 Amp, 250 V Fast-blo	Fused 6.3 Amp, 250 V Fast-blo
Ambient Temperature	+32° to 122°F (0° to 50°C)	
Status Indicators	Red LED indicates channel is energized.	
Adjustments	Two potentiometers for voltage adjustment of channel 1 and channel 2 output from 0 to full rated voltage. Frequency adjustment from 60 to 400 Hz to reduce clutch/brake "Hum" associated with machine frequencies. Jumper for single or dual operation. See appendix for explanation.	
Inputs:	3 Optically coupled, 10-30 VDC, 3-9 mA for Channel 1, Channel 2 and Channel 2 override (applies full voltage to channel 1 output)	

Enclosure (Optional)



- Lift off hinge
- Quick-release latches
- Conforms to NEMA Type 13
- European Standard IEC 529, IP65

Connection Diagram

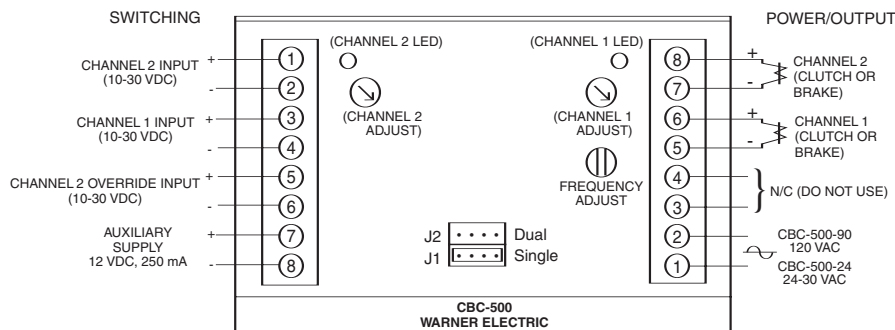

All dimensions nominal unless otherwise specified.

Part No.	6042-101-004
Size	8"H x 6"W x 4"D (203.2 x 152.4 x 101.6 mm)

Dimensions

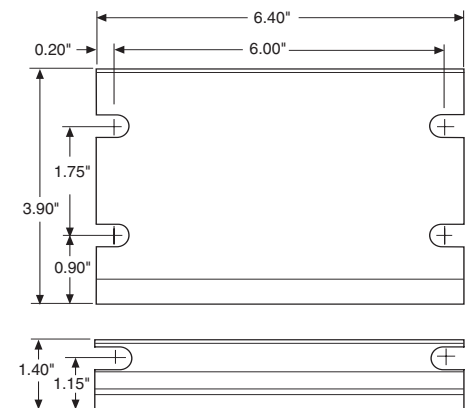

Panel Mounted

CBC-550 series Dual adjustable with power transformer

The CBC-550 series is a dual channel adjustable voltage control with optically coupled switching for 24 and 90 volt electric clutches and brakes. These controls can be set up to energize the two outputs alternately (single) or simultaneously (dual). Refer to the Appendix for additional setup and switching information.

The CBC-550 series has a power transformer which will operate with a 120, 220, 240, 380, or 480 VAC input.



- Dual adjustable channels
- Optically isolated input switching
- Single or dual channel operation
- Can be used with electrically released brakes



Specifications

	CBC-550-90	CBC-550-24
Part No.	6024-448-006	6024-448-005
Input Voltage	120/220/240/380/480 VAC	
Output Voltage	0-90 VDC	0-24 VDC
Output Current	1 Amp/Channel 1.2 Amps Total	4 Amps/Channel 4 Amps Total
Auxiliary Supply	12 VDC 250 mA	
Circuit Protection	Fused 1.5 Amp, 250 V fast-blo	Fused 5 Amp, 250 V fast-blo
Ambient Temperature	+32° to 122°F (0° to 50°C)	
Status Indicators	Red LED indicates channel is energized.	
Adjustments	Two potentiometers for voltage adjustment of channel 1 and channel 2 output from 0 to full rated voltage. Frequency adjustment from 60 to 400 Hz to reduce clutch/brake "Hum" associated with machine frequencies. Jumper for single or dual operation. See appendix for explanation.	
Inputs	3 Optically coupled, 10-30 VDC, 3-9 mA for Channel 1, Channel 2 and Channel 2 override (applies full voltage to channel 1 output)	

Enclosure (Optional)



- Lift off hinge
- Quick-release latches
- Conforms to NEMA Type 13
- European Standard IEC 529, IP65

Part No.	6006-101-007
Size	6"H x 6"W x 6"D (152.4 x 152.4 x 152.4 mm)

Dimensions

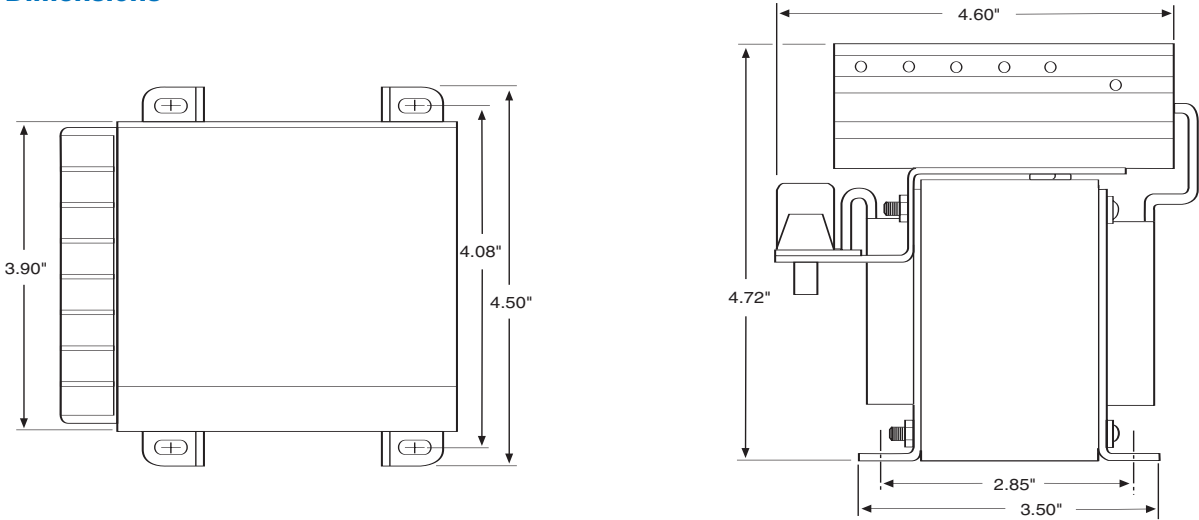

Connection Diagram

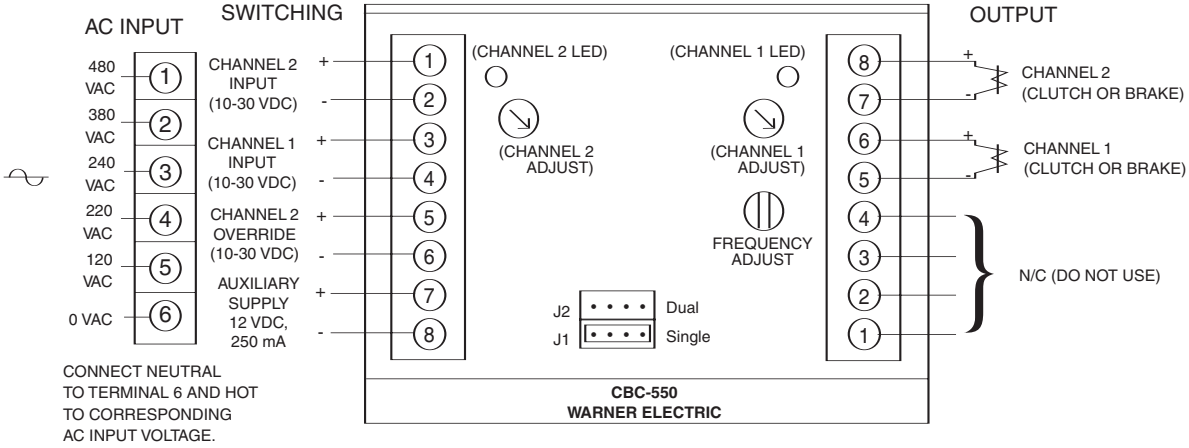

All dimensions nominal unless otherwise specified.

Panel Mounted

CBC-1825R series

The CBC-1825R is designed to provide consistent and repeatable acceleration and deceleration when used with Warner Electric 90 VDC clutches and brakes. Current to each channel is introduced along an adjustable time ramp and monitored continuously. Adjustments include initial pull-in pulse, hold level, maximum torque, and ramp time. LEDs are provided on the circuit board to indicate power is applied to the clutch or brake unit.

Note: It is recommended that the auto-gap springs be removed from the clutch and brake for successful accel-decel application.

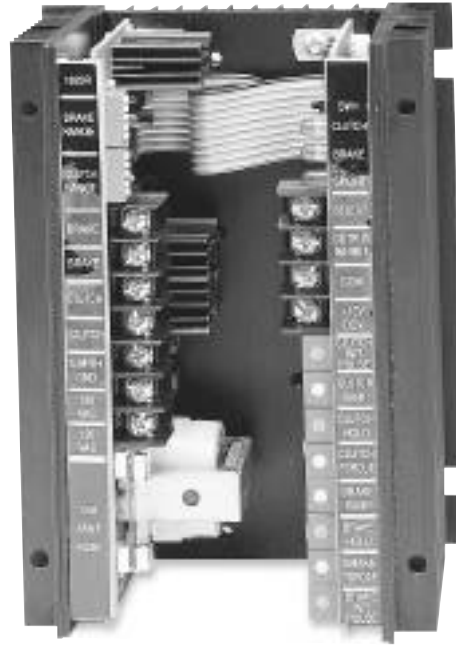

Specifications

CBC-1825R	
Part No.	1825-448-001
Input Voltage	120 VAC, 50/60 Hz, 100 VA maximum
Output Current	Current driven PWM, compatible with 90 VDC clutch/brake (switch selectable current output)
Auxiliary Supply	12 VDC 250 mA
Circuit Protection	Input Fused 1.5 Amp, 250 V fast-blo clutch and brake outputs are short circuit protected
Status Indicators	Clutch and brake LEDs indicate output is energized Short circuit LED indicates a fault
Ambient Temperature	0° to 122°F (-18° to 50°C)
Switching	Contact rating: 15 mA @ 15 V, open collector NPN 2mA maximum allowable leakage current and 2 V maximum saturation voltage

Set-up

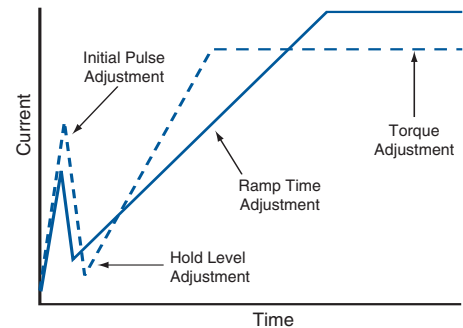

All dimensions nominal unless otherwise specified.

Dimensions

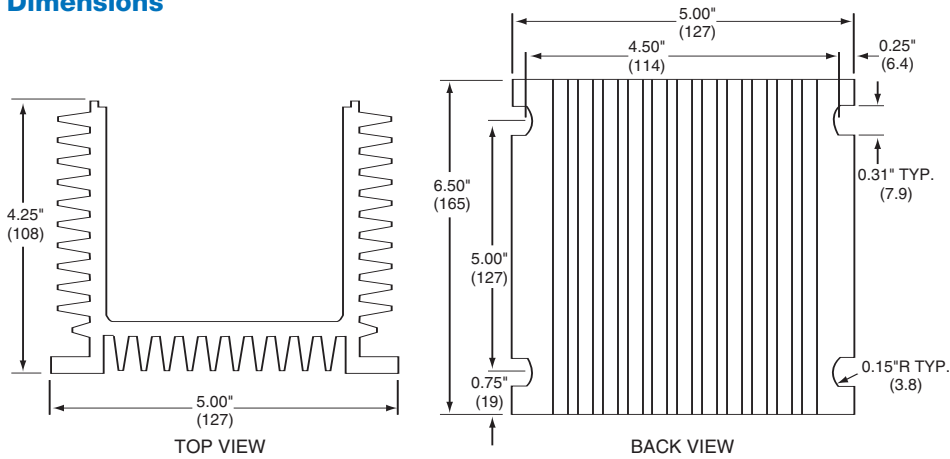

Connection Diagram

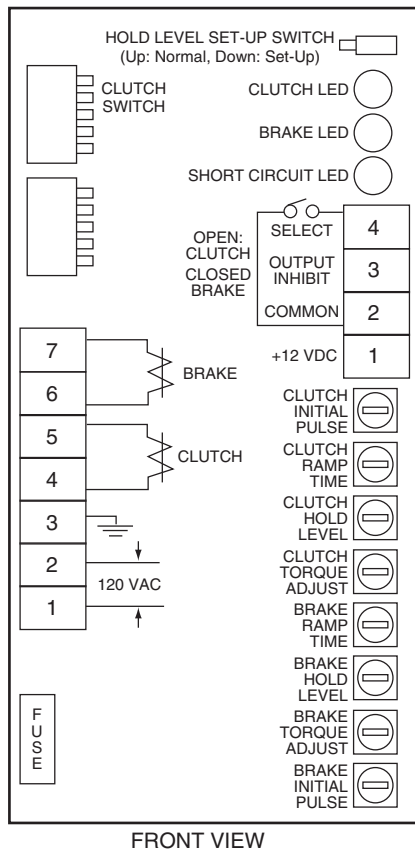

General Purpose OEX Control

CBC-700 series

Simple, compact, high performance OEX control for either 90 or 24 VDC clutches and brakes. OEX spike duration and anti-overlap times delay are adjustable. Two optically isolated inputs.



- High performance
- Switch selectable OEX duration
- Force decay suppression with adjustable anti-overlap time delay
- Compact, flexible mounting
- Models for 24 or 90 volt clutches and brakes
- Cycle rate limited by clutch/brake



Specifications

	CBC-700-90	CBC-700-24
Part No.	6042-448-003	6042-448-002
Input	120 VAC, 50/60 Hz	24-28 VAC, 50/60 Hz
Output Voltages		
Steady State	90 VDC	24 VDC
Overexcitation	340 VDC	105 VDC
Output Current (Per channel alternately)	.5 Amps	3.5 Amps
OEX Pulse Duration	Adjustable through logic board dip switches (see service manual)	
Inputs	Two-optically isolated (10-30 VDC)	
Ambient Temperature Range	0°F to 140°F (-18°C to +60°C)	
Maximum Off State Leakage	<2 mA (inputs)	
Circuit Protection	2.5A Slo-Blo (5 x 20 mm)	5A Slo-Blo (5 x 20 mm)
Auxiliary Supply	12 VDC, 250 mA maximum	

Enclosure (Optional)



- Lift off hinge
- Quick-release latches
- Conforms to NEMA Type 13
- European Standard IEC 529, IP65

Part No.	6042-101-004
Size	8"H x 6"W x 4"D (203.2 x 152.4 x 101.6 mm)

Dimensions

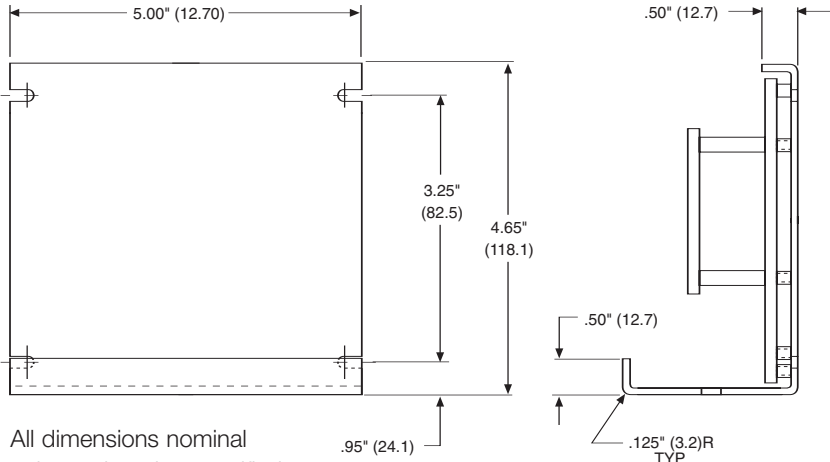

All dimensions nominal unless otherwise specified.

Connection Diagram

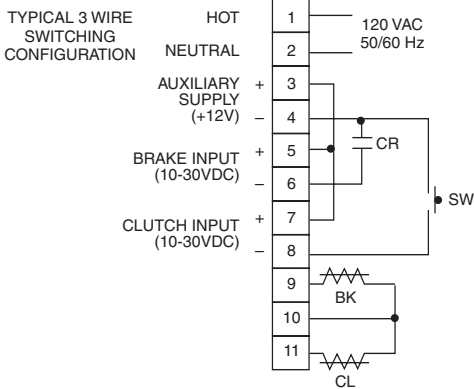

NOTE: CR, SW user furnished switch options for use with control.
CR normally open relay contact
SW normally open push button switch

Rapid Acceleration/Deceleration

**CBC-750 series
Dual channel, current based
OEX with switching logic**

Warner Electric's CBC-750 series of Constant Current Overexcitation Clutch/Brake Controls are solid-state electronic controls designed to increase the cycle rate capabilities and accuracies of electromagnetic clutches and brakes. The controls accomplish this by sending a momentary high voltage overexcitation spike to the clutch and/or brake magnetic coil to build a high density magnetic flux field almost instantaneously. By using overexcitation, the response time is reduced as dramatically as performance is increased. For example, the current build up time of a 5 inch, 6 volt magnet is reduced from 84 milliseconds to 2 milliseconds.

The CBC-750 user selects either 120, 220 or 240 VAC operation at the time of installation. Models for 6 volt, 24 volt, or 90 volt clutches and brakes are available.



- High performance OEX control
- Constant current output capability
- Models for 6, 24, and 90 V clutches and brakes
- Outputs short circuit protected.
- AC/DC optically isolated inputs
- Transformer isolation
Remote torque potentiometer capability
- Input/Output inhibit functions
- Switch selectable OEX function
- Automatic CH1/CH2 anit-overlap feature
- Heavy duty suppression circuits
- Selectable output current ranges
- Remote status indicators inputs and outputs



Shown with optional cover, part number 6041-101-004

LED indicators on the faceplate of each control tell the user the status of input signals, output activation and any auxiliary inputs. A reset switch resets the output should a short be detected. Remote torque adjust potentiometer inputs are also provided. Appropriate current range for each size clutch or brake is selected by a dip switch. Constant current for each level is assured by the control's design.

- Maintains torque at preset levels regardless of temperature variations
- Automatically controls OEX pulse duration for optimum response without overheating coils
- Automatically prevents clutch and brake "overlap"
- Configurable as an analog follower control through remote top input
- Integral switching logic through auxiliary, inhibit and override inputs

Specifications

	CBC-750-6	CBC-750-24	CBC-750-90
Part No.	6041-448-001	6041-448-002	6041-448-003
Input Power	120/220/240 VAC, ±10%, 50/60 Hz, 350 VA (switch selectable)		
Control Inputs	Opto-isolated 10-30 VDC @ 10-35 mA nominal sinking or sourcing, or 24 VAC (50/60Hz) @ 22 mA nominal, or 120 VAC (50/60 Hz) @ 20 mA nominal		
Clutch/brake Output			
Steady State Output			
Current controlled	.910 to 4.34 A max.	.227 to 1.175 A max.	.060-.310 A max.
Current Rise Time	Dependent on clutch/brake size		
Current Fall Time	Depending on clutch/brake size		
Overexcitation Voltage	75 VDC nom.	240 VDC nom.	450 VDC nom.
Overexcitation Time	Automatic adjustment by control feedback		
Anti-overlap Time	Automatic adjustment by control feedback		
Power Supply Output	12 VDC, ±0.6 VDC, 250 mA max.		
Auxiliary Indicator	Opto-isolated NPN transistors		
Outputs	24 VDC maximum, 20 mA max., reverse polarity protected		
Circuit Protection	Internal short circuit protection on each output channel.		
Fusing			
AC Input Line	2 Amp, 250 V Slo-Blo		
OEX Supply	10 Amp, 32 V Slo-Blo	5 Amp, 250 V Slo-Blo	1 Amp, 250 V Slo-Blo

Seven optically isolated inputs accept 10-30V A.C./D.C. (TB2) or 120 VAC (TB3), configured through set-up switches

1. Channel 2 Input
2. Channel 2 Input Inhibit (disregards channel 2 input signal)
3. Auxiliary Input
4. Channel 1 Input
5. Channel 1 Input Inhibit (disregards channel 1 input signal)
6. Output Inhibit (deactivates both output channels)
7. Channel 2 Override (applies full voltage to channel 1 output)

Connection Diagram

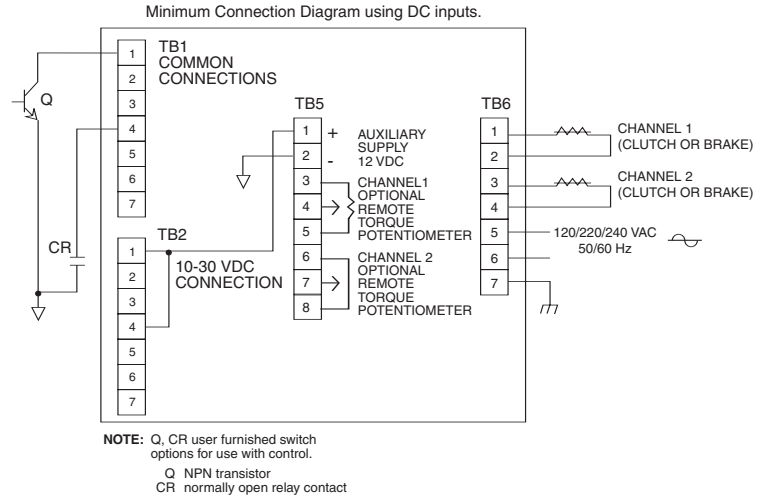

Dimensions

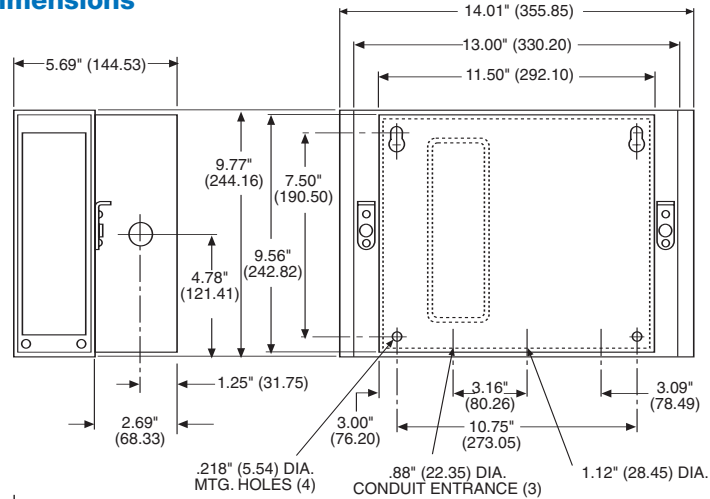

All dimensions nominal unless otherwise specified.

Setup Switches

SW1: AC Voltage selection switch on terminal board inside control unit

Max. Current Output

(SW7 & SW8 settings)

Nominal Voltage	1	2	3	4	5
6	0.910	2.35	3.183	3.760	4.340
24	0.227	0.641	0.881	0.940	1.175
90	0.060	0.176	0.256	0.282	0.310

SW8

Channel 2 current range selector (settings in diagram below)

SW7

Channel 1 current range selector (settings in diagram below)

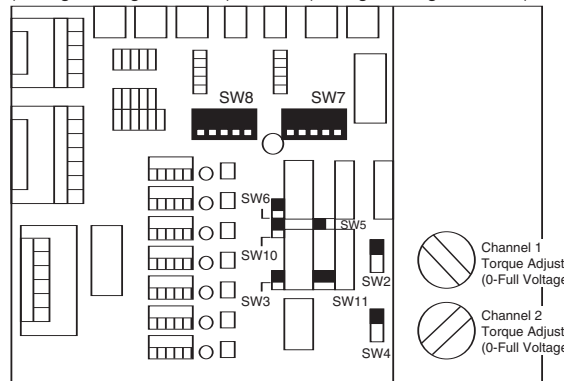

All switches are in the down (v) position from factory

SW6

Channel 2 OEX enable (v) / disable (Δ)

SW10

Channel 1 input invert (v) / (Δ)

SW3

Level/pulse selector level (Δ) / pulse (v)

SW5

Channel 1 OEX enable (v) / disable (Δ)

SW2

Channel 1 local (Δ) / or remote (v) torque adjust

SW4

Channel 2 local (Δ) / or remote (v) torque adjust

SW11

Auxiliary input selector Channel 1 (Δ) / Channel 2 (v)

System Accuracy

CBC-1000

Position-loop control with error correction compensation

Warner Electric's CBC-1000 is a closed-loop positioning control with error compensation designed for industrial clutch/brake applications. The position loop is closed through encoder feedback which generates pulses proportional to load motion. The CBC-1000 uses this feedback to determine the optimum brake actuation point. The control can be programmed to operate in one of two distinct modes: absolute or incremental. The CBC-1000 includes eight solid state control outputs, a batch counter and a serial communications interface.

The CBC-1000 system consists of four key elements: the CBC-1000, a clutch/brake, a clutch/brake control, and an encoder. Nearly any electric clutch/brake size and configuration can be used. The clutch/brake control should have solid-state compatibility. Simple on-off, soft start/stop, and overexcitation controls may all be utilized based on the desired velocity profile.



Specifications

Part No.	6060-448-001
Input Power	100 to 130 VAC, 50/60 Hz, 20VA (200 to 260 VAC selectable)
Auxiliary Supply	12 VDC @ 175 mA Used for powering encoder, etc.
Main Counter	
Range	6 Decades
Reset Input	External and front panel
Count Rate	(20 kHz external input frequency)
Batch Counter	
Range	6 Decades
Reset	Through front panel only
Signal A and B Inputs	
Input Frequency	D.C., 20 kHz quadrature max.
Input High Level	3.25 VDC min.
Input Low Level	1.75 VDC max.
Control Inputs	
Input Frequency	D.C. to 20 Hz max. each input
Input Type	Single ended, current sinking
Input Logic	Both Edge and Level sensitive as defined by input use
Input High Level	10 VDC min. to 20 VDC max.
Input Low Level	0 VDC min. to 2 VDC max.
Input Current	2.5 mA steady state
Display	
Decades	7 Decade, 0.6" red LED
Decimal Point	User programmable Range: xxx.xxx to xxxxxx
Program Security	Program LOCK of lines 1 - 33
Control Outputs	
Type	8 Solid State 100 mA sink max., 24 VDC max.
Serial Interface	
Type	RS-422A/485 compatible
Baud Rate	Selectable: 300, 600, 1200, 2400
Parity	Selectable: None, Odd, Even
Data	ASCII
Diagnostics	Nine Self-Test Diagnostics
Mechanical	
Enclosure	Aluminum extrusion with molded VALOX bezel.
Weight	2.5 lbs.
Environmental	
Operating Temp.	0° to +50°C (32° to 122°F)
Storage Temp.	-18° to 85°C (0° to 186°F)
Ambient Humidity	90% and noncondensing

Accessories

Description	Part Number
Encoder Cable (Accessory)	6060-101-001
100 PPR Encoder w/10' cable	6060-101-010
250 PPR Encoder w/10' cable	6060-101-025
600 PPR Encoder w/10' cable	6060-101-060
1200 PPR Encoder w/10' cable	6060-101-120
2500 PPR Encoder w/10' cable	6060-101-250
5000 PPR Encoder w/10' cable	6060-101-500

(PPR-Pulse Per Revolution)

Serial Interface Module



Performs the necessary voltage level conversions to interface the RS-422A/485 output of the CBC-1000 to RS-232C equipment.

Part Number: 6060-101-232

1. Select the proper clutch/brake

- Determine torque and inertia requirements
- Calculate heat dissipation for required cycle rate
- For best accuracy, mount clutch/brake directly on nip or drive shaft; avoid backlash

2. Select quadrature encoder

- Select encoder PPR for desired system resolution (i.e. inches/pulse, degrees/pulse, etc.)
- Determine input frequency; do not exceed 20,000 pulses/sec.
- Mount encoder directly to nip or drive shaft for best accuracy

3. Select clutch/brake power supply

- Use CBC-700 overexcitation control for best accuracy
- Use CBC-500/550 for soft starting and/or stopping
- Brake autogap may have to be removed for best accuracy

4. Plan system logic (switching requirements)

- Use absolute mode for indexing applications such as conveyors and turntables or cutoff applications where close registration is required
- Use incremental mode for cutoff applications
- Determine switching and relays required for machine operation

5. Select serial interface module if applicable.

Timing Diagram

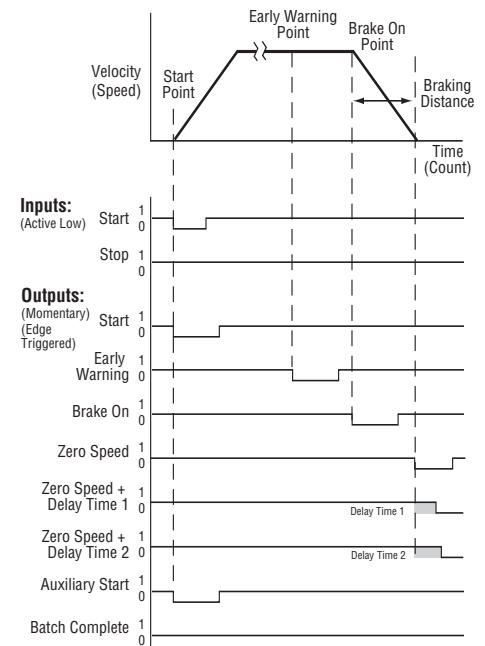

Operation

Successful operation will require knowledge of the following definitions and their relationships to the timing diagram.

Function Key Definitions

Count	1 COUNT	The actual move distance, in pulses or scaled into engineering units (inches, feet, rotations, degrees, etc.) displayed dynamically.
Move Present	2 MOV PST	The desired move distance in pulses or scaled into engineering units. This is the value the operator enters to select a new move distance.
Early Warning	3 E.W.	A distance prior to Move Preset at which the early warning output is activated. Expressed as pulses or engineering units, this output can be used to accomplish a soft brake (slow down), energize valves, etc.
Batch	6 BATCH	A cumulative batch counter that can be dynamically displayed to show the number of operations, cycles, etc. When this counter reaches the value programmed by the Batch Preset (key 7) the Batch Complete Output is activated. The batch counter can be manually or automatically reset.
Batch Preset	7 BCH PST	A programmable batch counteractivates the batch complete output when the value programmed has been reached by the batch (key 6)
Braking Distance	8 BRK DIS	The actual distance required to stop. This value is dynamically updated to determine the brake actuation point. Factory default is 25 pulses or engineering units which is only used for the first cycle after power-up. After the first cycle the CBC-1000 will tune to the particular brake being utilized. The amount of cycles needed for tuning depends on how far the true braking distance value is from the default of 25.

Appendix

CBC-400/450/500/550 Single vs Dual Operation

The CBC 400 and 500 series controls allow operation in either a single or dual mode. The mode of operation is determined via the position of a jumper on the main control board.

The controls are shipped with the jumper in the J1 or single mode position. A variety of output logic can be accomplished via the single/dual jumper position and whether the control is wired to one input switching device (2-wire mode) or two input switching devices (3-wire mode). The following diagrams show how each channel (output) of the control can be either alternately or simultaneously energized.

2-wire Switching Option

Control's switching terminal block

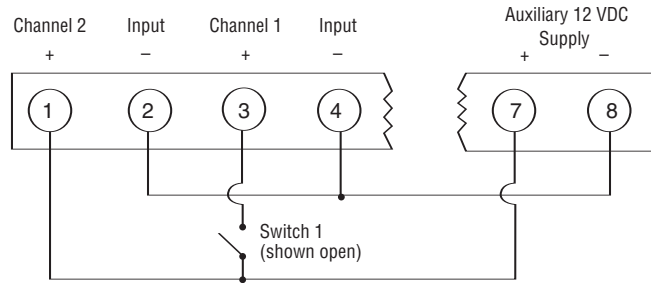

Jumper Mode	Switch 1	Channel 1	Channel 2
J1-Single	Open Closed	Off Powered	Powered Off
J2-Dual	Open Closed	Powered Off	Powered Off

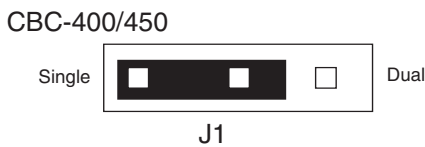
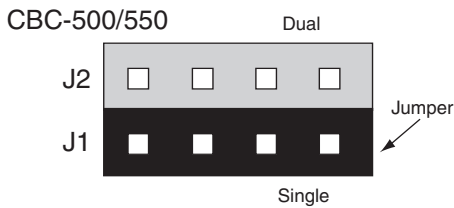

3-wire Switching Option

Control's switching terminal block

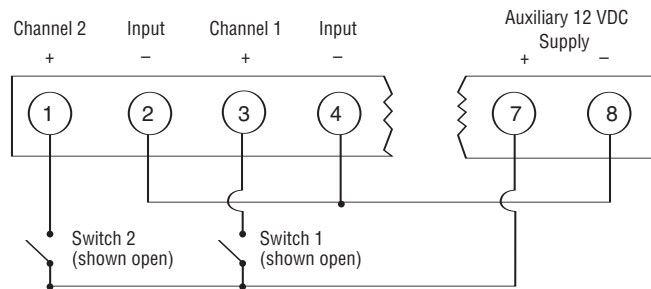

Jumper Mode	Switch 1	Switch 2	Channel 1	Channel 2
J1-Single	Closed Open	Open Closed	Latched On Off	Off Latched On
J2-Dual	Closed Open	Open Closed	Off Latched On	Off Latched On

1. What transformers can be used with controls requiring 24-30 VAC input?

Manufacturer	Part Number	Primary	Secondary
Abbott	6B 12-160	115 VAC	24V @ 6 amps
Quality	6-K-119VBR	115/230 VAC	24V @ 8 amps
Signal	24-6	115 VAC	24V @ 6 amps
Signal	DP24-6	115/230 VAC	24V @ 6 amps
Triad	F-260-U	115 VAC	24V @ 6 amps

2. When a single clutch or brake is used with a CBC-200 and no switch is used, a jumper wire is required across terminals 5 & 6 to get output at terminals 4 & 5.

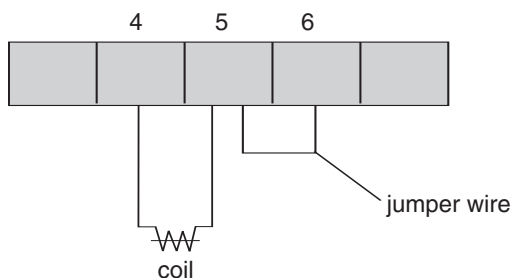

3. What is the difference between a MCS-801 and a CBC-801-1 or between a MCS-103 and a MCS-103-1?

There is no performance difference between the MCS-103 and MCS-103-1. There is no performance difference between the MCS-801 and CBC-801-1. The CBC-801-1 is roughly 1/4" shorter than the MCS-801. The units wire and work exactly the same.

4. Which power supplies can be used with the SF 1525HT and SFC 1525HT coil?

The SF and SFC 1525 High Torque clutch coils require .794 amps of current to provide full rated torque. The following power supplies and controls will provide the needed power.

CBC-100	.8 amps	CBC-450	1 amp
CBC-150	.8 amps	MCS-103-1	1.25 amps
CBC-801	1.25 amps	CBC-500	1 amp
CBC-400	1 amp	CBC-550	1 amp

5. Can I use a CBC-160 with a variable frequency drive and AC motor?

No. As the voltage to the drive is varied, the output to the electrically released brake would also vary. This would cause the brake to re-engage when it should be released.

6. Which power supplies offer a 12 VDC power source that could be used to power auxiliary switch inputs such as inductive or photoelectric sensors?

CBC-400, CBC-450, CBC-500,
CBC-550, CBC-700, CBC-750

7. Is the CBC-1000 a stand-alone control?

No. The CBC-1000 provides closed loop feedback for a clutch/brake system. A common system will consist of four components:

- a Warner Electric brake and clutch
- a Warner Electric power supply
- an Encoder
- a CBC-1000 position control

The application criteria will determine which clutch/brake and which control will be appropriate selections.

8. Which of the controls would allow for the independent operation of two clutches or two brakes?

Four controls allow for completely independent operation of two clutches or brakes. That is, that a clutch and brake can both be on at once, both off at once, or one on and one off. These controls are:

CBC-801-1 and CBC-801-2, MCS-103-1, CBC-200, CBC-300

The CBC-400/450 and CBC-500/550 allow for operation of both channels on at once, both channels off at once or cycling between channel one and two. However, in the both-on/both-off mode, you cannot also do independent single channel operation.

9. Are there any controls that can be used to control the torque of a 90 volt clutch or brake via an analog signal input?

Not currently. However, the TCS-200 and TCS-200-1 both provide signal following capabilities for use with units with 24 volt coils. These units can follow a 0-10 volt or 4-24 ma input signal.

10. Which controls can be used with electrically released brakes?

The CBC-160-1 and CBC-160-2 are designed specifically to use with the conduit box of EM and EUM electrically released brake designs. The CBC-160-1 and CBC-160-2 can also be used with ER and FB brake designs.

The MCS-103-1, CBC-200, CBC-300 and CBC-500/550 can all be used with ER, FB as well as UM-FBC, EM and EUM-FBB and EM and EUM-MBFB designs.

The MCS 805-1 and MCS 805-2 are for use only with the ER 1225 brakes. The ERS series brakes can be used with the CBC-100 or CBC-801 power supplies.

Ordering Information

Model	Part Number	Page
CBC-100-1	6003-448-101	144
CBC-100-2	6003-448-103	144
MCS-103-1	6010-448-002	150
CBC-150-1	6004-448-001	144
CBC-150-2	6004-448-002	144
CBC-160-1	6013-448-001	145
CBC-160-2	6013-448-002	145
CBC-200	6011-448-001	152
CBC-300	6021-448-001	152
CBC-400-24	6006-448-002	148
CBC-400-90	6006-448-003	148
CBC-450-24	6006-448-005	149
CBC-450-90	6006-448-006	149
CBC-500-24	6024-448-002	153
CBC-500-90	6024-448-003	153
CBC-550-24	6024-448-005	154
CBC-550-90	6024-448-006	154
CBC-1825R	1825-448-001	156
CBC-700-24	6042-448-002	158
CBC-700-90	6042-448-003	158
CBC-750-6	6041-448-001	160
CBC-750-24	6041-448-002	160
CBC-750-90	6041-448-003	160
CBC-801-1	6001-448-004	146
CBC-801-2	6001-448-006	146
Octal Socket, Foot Mount	6001-101-001	146,147
Octal Socket, DIN Rail Mount.....	6001-101-002	146,147
CBC-802	6002-448-001	147
CBC-1000	6060-448-001	162
Serial Interface Module.....	6060-101-232	162
Encoders: Cable (Accessory)	6090-101-001	162
100 PPR	6060-101-010	162
250 PPR	6060-101-025	162
600 PPR	6060-101-060	162
1200 PPR	6060-101-120	162
2500PPR	6060-101-250	162
5000PPR	6060-101-500	162
Optional Enclosure: CBC-400, CBC-500, CBC-700 ...	6042-101-004.....	148, 153,158
Optional Enclosure CBC-450, CBC-550	6006-101-007	149, 154
MCS-805-1	6090-448-006	151
MCS-805-2	6090-448-007	151

Distribuidor Autorizado e Importador - Arten Freios e Embreagens Ltda.

Fone: (11) 5594-8333 • Fax (11) 5589-2422 - arten@arten.com.br • www.arten.com.br