

Airflex® Type DC Element Description

Section E

Type DC elements can be used as either pressure actuated clutches or brakes. They are available in single and multiple disc designs.

Element construction and operation is illustrated in the figure. Pressurizing the cylinder causes the piston to clamp the friction disc assemblies between clamping plates. External springs ensure positive disengagement.

Type DC elements are available in five basic disc sizes with static torque ratings to 2,061,000 lb·in (233.000 N·m). Element sizes are indicated by the number of friction discs and by the disc diameter in inches. For instance, size 225DC has two friction discs 25 inches in diameter.

Features

Favorable torque to size ratio.

DC type elements are physically smaller than most other type clutches and brakes with the same torque capacity.

Low inertia friction disc assembly.

Reduces the overall inertia that must be started or stopped.

Optional split friction discs.

Allows removal of friction discs without disturbing other components of drive system in mid-shaft element arrangement.

Long wearing, self lubricating PolyPak* seals.

Eliminates premature twisting failure and requires no external lubrication.

Where used:

- Power Presses
- Tension Brakes
- Emergency Stop Brakes on Unwind Stands

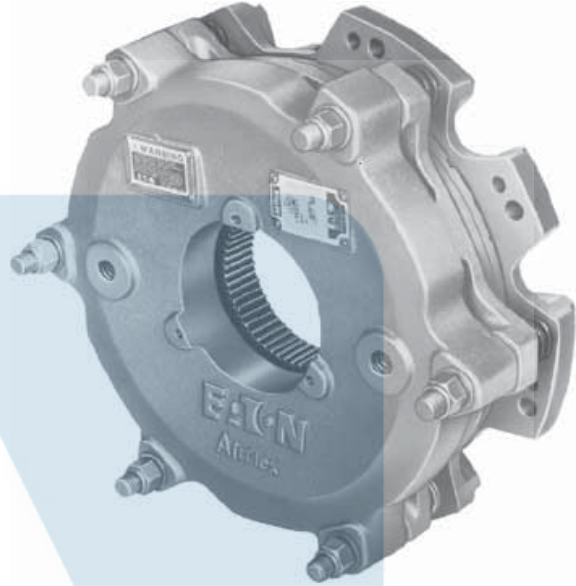

ARTEN

Airflex® DC Component Parts

Section E

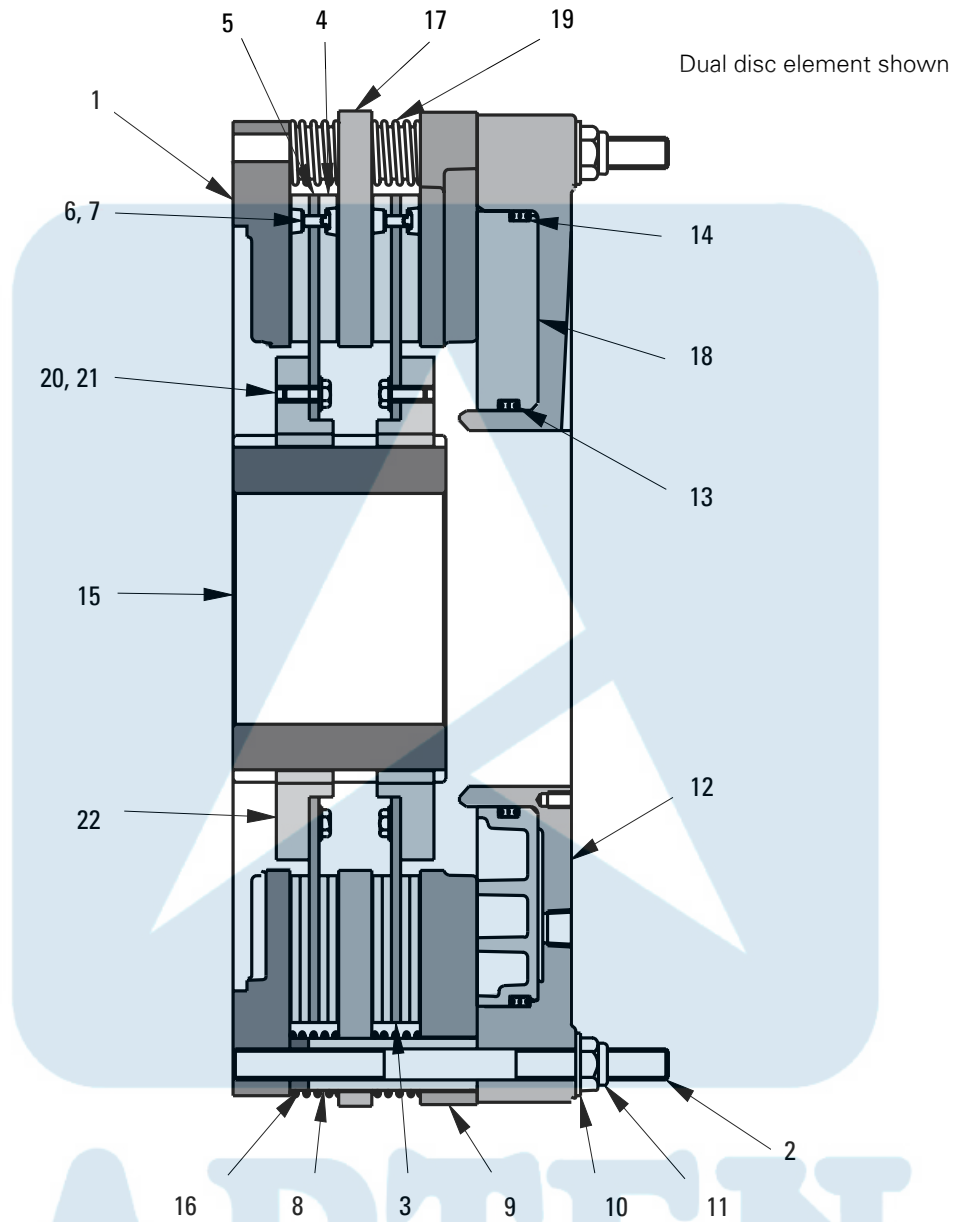

| Item Number | Description | Item Number | Description |
|-------------|----------------------------|-------------|----------------|
| 1 | Mounting Flange | 12 | Cylinder |
| 2 | Stud | 13 | Inner Seal |
| 3 | Friction Disc Sub-Assembly | 14 | Outer Seal |
| 4 | Friction Disc | 15 | Gear |
| 5 | Friction Disc Core | 16 | Wear Spacer |
| 6 | Rivet | 17 | Reaction Plate |
| 7 | Washer | 18 | Piston |
| 8 | Clamp Tube | 19 | Release Spring |
| 9 | Pressure Plate | 20 | Flat Washer |
| 10 | Flat Washer | 21 | Hex Head Screw |
| 11 | Locknut | 22 | Ring Gear |

Airflex® Type DC Elements

Dimensional Data

Section E

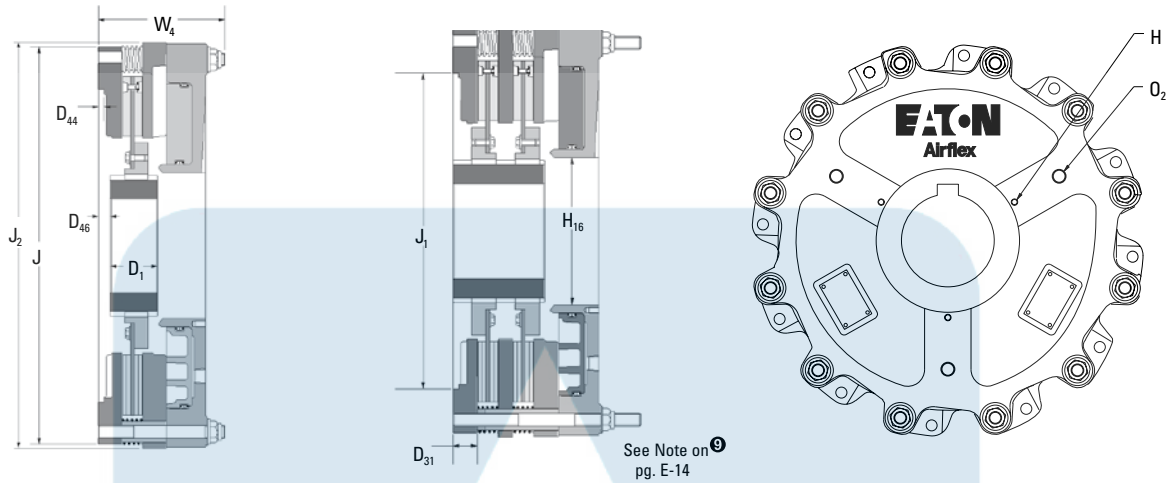

| English | Dimensions in inches | | | | | | |
|---------|----------------------|--------|------|-------|-------|-------|------|
| 109DC | 146239 | 415313 | 1.75 | 2.38 | 1.75 | 5.63 | 0.25 |
| 209DC | 146240 | 415510 | 1.88 | 2.38 | 3.25 | 7.63 | 0.25 |
| 115DC | 146225 | 415454 | 2.75 | 3.98 | 2.88 | 7.00 | 0.38 |
| 215DC | 146226 | 415454 | 3.44 | 3.94 | 4.38 | 9.00 | 0.38 |
| 120DC | 146301 | 415900 | 3.31 | 5.63 | 3.00 | 8.00 | 0.75 |
| 220DC | 146317 | 415959 | 4.25 | 5.69 | 5.63 | 11.50 | 0.00 |
| 320DC | 146366 | 416304 | 4.88 | 5.56 | 8.25 | 14.63 | 0.00 |
| 420DC | 146390 | 416472 | 5.38 | 5.69 | 12.50 | 16.25 | 0.00 |
| 125DC | 146316 | 416073 | 4.38 | 7.13 | 3.50 | 9.50 | 0.75 |
| 225DC | 146355 | 416074 | 5.50 | 7.13 | 7.00 | 12.00 | 0.38 |
| 325DC | 146354 | 416623 | 6.25 | 6.88 | 9.31 | 14.50 | 0.00 |
| 425DC | 146389 | 416477 | 6.25 | 6.88 | 12.00 | 18.00 | 0.00 |
| 138DC | 146307 | 416068 | 6.75 | 10.50 | 5.00 | 13.50 | 1.25 |
| 238DC | 146336 | 416069 | 8.50 | 10.25 | 9.00 | 16.50 | 0.00 |
| 338DC | 146360 | 416241 | 9.25 | 9.75 | 13.00 | 19.50 | 0.00 |
| 438DC | 416388 | 416461 | 8.50 | 10.25 | 18.00 | 25.00 | 0.00 |

| SI | Dimensions in millimeters | | | | | | |
|-------|---------------------------|--------|-----|-----|-----|-----|----|
| 109DC | 146239 | 415313 | 44 | 60 | 44 | 143 | 6 |
| 209DC | 146240 | 415510 | 48 | 60 | 83 | 194 | 6 |
| 115DC | 146225 | 415454 | 70 | 98 | 73 | 178 | 10 |
| 215DC | 146226 | 415454 | 87 | 100 | 111 | 229 | 10 |
| 120DC | 146301 | 415900 | 97 | 143 | 76 | 203 | 19 |
| 220DC | 146317 | 415901 | 108 | 143 | 143 | 292 | 0 |
| 320DC | 146366 | 416304 | 124 | 141 | 210 | 372 | 0 |
| 420DC | 146390 | 416374 | 137 | 145 | 277 | 413 | 0 |
| 125DC | 146316 | 416073 | 111 | 181 | 89 | 241 | 19 |
| 225DC | 146355 | 416074 | 140 | 181 | 178 | 305 | 10 |
| 325DC | 146354 | 416623 | 159 | 175 | 236 | 368 | 0 |
| 425DC | 146389 | 416477 | 159 | 175 | 305 | 457 | 0 |
| 138DC | 146307 | 416068 | 171 | 267 | 127 | 343 | 32 |
| 238DC | 146336 | 416069 | 216 | 260 | 229 | 419 | 0 |
| 338DC | 146360 | 416241 | 235 | 248 | 330 | 495 | 0 |
| 438DC | 146388 | 416461 | 216 | 260 | 457 | 635 | 0 |

| Size | Part # | Gear Part Number | Bore Range | D ₁ | W ₄ | D ₄₆ |
|------|--------|------------------|------------|----------------|----------------|-----------------|
|------|--------|------------------|------------|----------------|----------------|-----------------|

| Size | Part # | Gear Part Number | Bore Range | D ₁ | W ₄ | D ₄₆ |
|------|--------|------------------|------------|----------------|----------------|-----------------|
|------|--------|------------------|------------|----------------|----------------|-----------------|

| English | Dimensions in inches | | | | | |
|---------|----------------------|------|-------|---|------------|-------|
| 9DC | 1.00 | 0.25 | 3.25 | 3 | 1/4-20NC-2 | 3.50 |
| 15DC | 1.47 | 0.38 | 6.00 | 3 | 3/8-16NC-2 | 6.50 |
| 20DC | 1.50 | 0.38 | 8.50 | 3 | 3/8-16NC-2 | 9.13 |
| 25DC | 1.75 | 0.25 | 11.50 | 4 | 3/8-16NC-2 | 12.25 |
| 38DC | 2.45 | 0.25 | 16.50 | 4 | 1/2-13NC-2 | 17.50 |

| Size | D31 | D44 | H16 | H | No. | Size | Bolt Circle | J ♂ | J1 ♂ | J2 ♂ | O2 ♂ |
|------|-----|-----|-----|---|-----|------------|-------------|--------|-------|------|--------|
| 9DC | 25 | 6 | 83 | 3 | 3 | 1/4-20NC-2 | 89 | 308,0 | 212,7 | 314 | 3/8-14 |
| 15DC | 37 | 10 | 152 | 3 | 3 | 3/8-16NC-2 | 165 | 466,7 | 365,1 | 481 | 1/2-14 |
| 20DC | 38 | 10 | 216 | 3 | 3 | 3/8-16NC-2 | 232 | 590,6 | 463,5 | 605 | 1/2-14 |
| 25DC | 44 | 6 | 292 | 4 | 4 | 3/8-16NC-2 | 311 | 778,0 | 619,1 | 777 | 1/2-14 |
| 38DC | 62 | 6 | 419 | 4 | 4 | 1/2-13NC-2 | 445 | 1136,7 | 923,9 | 1139 | 3/4-14 |

| SI | Dimensions in millimeters | | | | | | | | | | | |
|----|---------------------------|--|--|--|--|--|--|--|--|--|--|--|
|----|---------------------------|--|--|--|--|--|--|--|--|--|--|--|

Notes are on page E - 14

Airflex® Brake Selection Procedure

Section E

Torque and Thermal Capacities

General

Technical Section Y of the catalog contains useful information pertaining to the selection, mounting, alignment and control of clutches and brakes in general. Formulas, symbols and units are also identified. It is recommended that Section Y be reviewed before attempting to size a specific product for an application.

Torque

DBA and DBB Brakes

The torque ratings are dependent upon spring force and quantity, not a pressurizing medium. However, a pressurizing medium is required to compress the springs to release the brake. Minimum releasing pressures, as well as the maximum pressures which the piston and cylinder can withstand, are given on the catalog pages.

Type DBA and DBB brakes are disc type and develop equal torque in both directions of rotation. Several springs are used in their design. If brake size is determined by thermal requirements rather than torque requirements, brake torque can be reduced by spring removal.

For spring applied brakes, torque will decrease with lining wear, due to the longer piston travel required for engagement. Single disc DBA and DBB brakes have no provision for adjustment. Multiple disc brakes have a provision for adjustment after a given amount of lining wear. Therefore, DBA and DBB brake torque with worn linings must be considered in the selection process.

DC Elements

DC element dynamic torque ratings M_r are based on an effective pressure p_r of 75 psi (5,2 bar). Maximum allowable operating pressure is 120 psi (8,3 bar). Torque ratings must be adjusted for operating pressure p_o and parasitic loss p_p .

The elements have an inherent parasitic pressure p_p , required to cause friction disc engagement, which represents the pressure to overcome internal sliding friction and to compress disc releasing springs.

| No. of Friction Discs | Pressure p_r | |
|-----------------------|----------------|------|
| | psi | bar |
| 1 | 3 | 0,21 |
| 2 | 4 | 0,28 |
| 3 | 5 | 0,34 |
| 4 | 6 | 0,41 |

Element torque is calculated from:

$$M_e = \frac{p_o - p_p}{p_r} \cdot M_r$$

Cyclic and Non-Cyclic Thermal Capacity

Brake types DBAV and DBB were designed for cyclic stopping applications. They are capable of a maximum thermal capacity P_c of 0.012 HP/in².

Non-cyclic thermal capacity is determined by the element's friction area, drum or disc mass, material heat capacity and thermal conductivity. The properties of our standard elements result in the limits indicated in the Non-Cyclic Energy Capacity Graph. An explanation on the use of this graph follows.

The thermal energy calculated for the load is adjusted to include the energy associated with accelerating or decelerating the components of the tentative clutch and/or brake selection. The adjusted thermal energy W_t is divided by the element's friction area A . Next, the average power loading P_{ave} is calculated from:

$$P_{ave} = \frac{W_t}{A}$$

The point ($W_t/A, P_{ave}$) is plotted on the graph. If the point falls below the appropriate product limit line, the selection will handle the load. If it does not, an element having a greater friction area is required.

ARTEN

Airflex® Selection Procedure

Section E

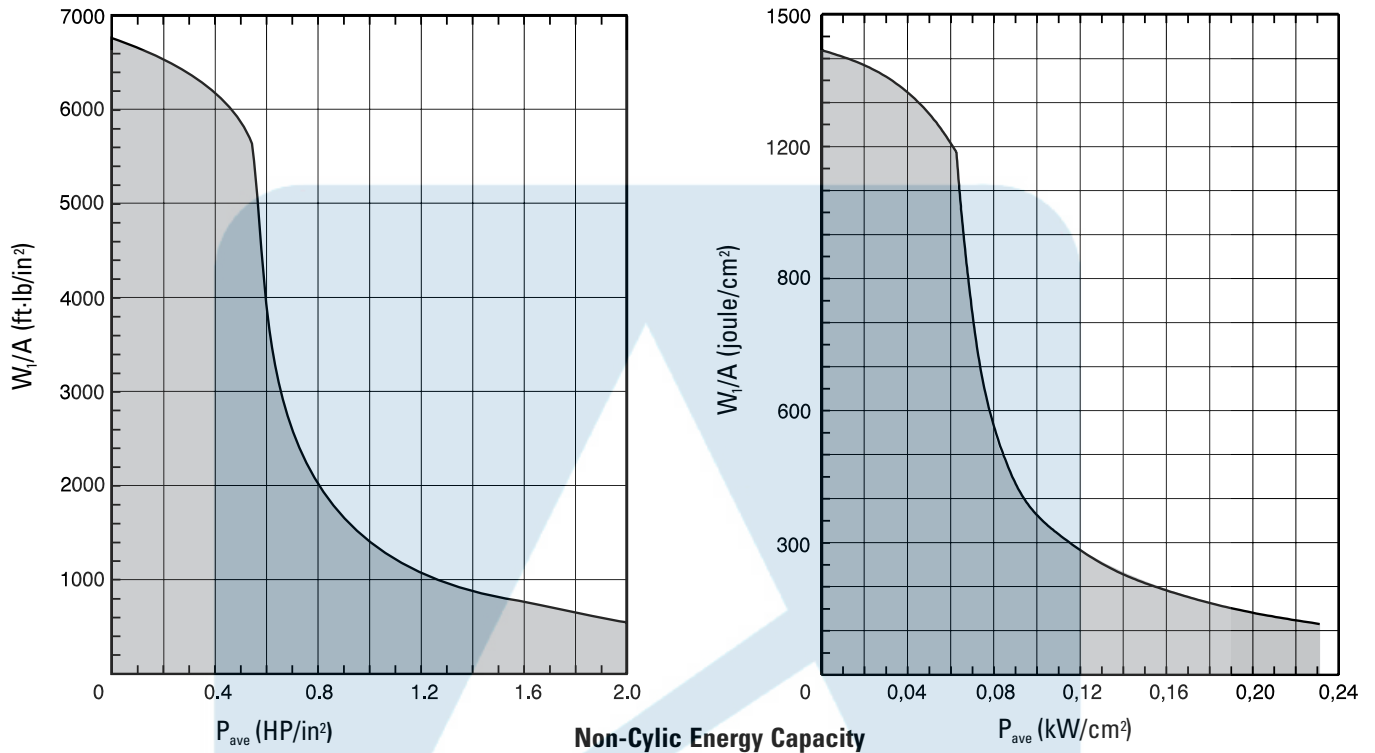

Example

A cyclic stopping brake is required for use on a power press operating under the following conditions. Determine the brake size and allowable cyclic rate.

Brake shaft speed: 300 rpm

Stopping angle at crankshaft: 15°

Inertia referred to brake shaft: 750 lb·ft²

Press stroke: 10 in

Ram and die weight: 2500 lb

Reduction between brake shaft and crankshaft: 10:1

Stopping angle at brake shaft $\theta_d = 15^\circ \cdot 10 = 150^\circ$

$$t_d = \frac{\theta d}{3 \cdot n} = \frac{150^\circ}{3 \cdot 300} = 0.17 \text{ sec.}$$

$$M_b = \frac{Wk^2 \cdot n}{25.58 \cdot t_d} = \frac{750 \cdot 300}{25.58 \cdot 0.17}$$

$$= 51,700 \text{ lb-in}$$

Reverse brake torque required =

0.5-stroke-weight/reduction

$$= 0.5 \cdot 10 \cdot 2500 / 10$$

$$= 1250 \text{ lb-in}$$

From required torques, select 215DBB

Lining area = 476 in²

Disc and gear $WK^2 = 10 \text{ lb-ft}^2$

Total $WK^2 = 750 + 10 = 760 \text{ lb-ft}^2$

$$W = \frac{Wk^2 \cdot n^2}{5873} = \frac{760 \cdot 300^2}{5873}$$

$$= 11650 \text{ ft-lb}$$

$$P_c = \frac{W \cdot \text{cpm}}{33000}$$

$$\text{cpm} = \frac{P_c \cdot 33000}{W}$$

$$= \frac{0.012 \cdot 476 \cdot 33000}{11650}$$

$$= 16$$