

Catalogo 2008

# FRENI A PINZA PNEUMATICI

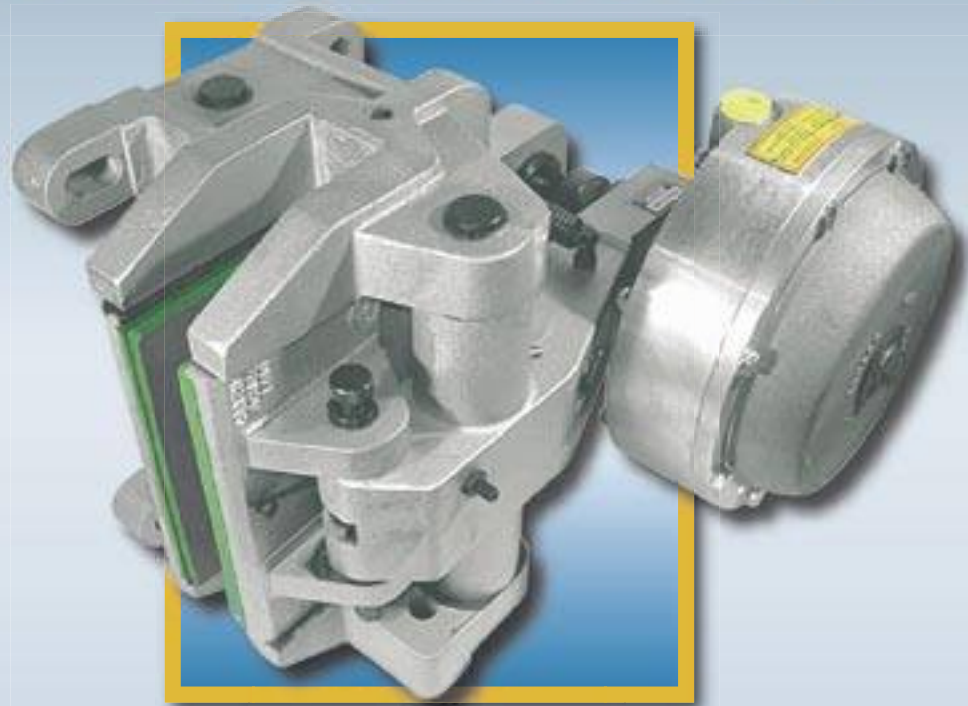

## PNEUMATIC CALIPER BRAKES



**COREMO OCMEA**

manufactures mechanical, pneumatic or hydraulic brakes and clutches for the industries of wire & cable, metalforming, steel, textile, paper, converting, packaging and for all other industrial applications. COREMO OCMEA, established 1960, is based in Assago - Milan (Italy) with a 3.200 m<sup>2</sup> plant.

**COREMO OCMEA**

produit des freins et des embrayages mécaniques, pneumatiques ou hydrauliques pour les tréfileries, les câbleries, le travail du métal, la sidérurgie, le textile, le papier, l'emballage, le conditionnement et toutes autres applications industrielles. COREMO OCMEA fondée en 1960 est basée à Assago - Milan (Italie) sur un site de 3200 m<sup>2</sup>.

**COREMO OCMEA**

produziert mechanisch, pneumatisch und hydraulisch betätigte Bremsen und Kupplungen für verschiedene Industrien wie Draht & Kabel, Blech, Stahl, Textil, Papierherstellung, Papierverarbeitung, Verpackung und andere industrielle Anwendungen. COREMO OCMEA, gegründet 1960, ist in Assago - Mailand (Italien) beheimatet und verfügt über 3.200 m<sup>2</sup> Büro- und Produktionsfläche.

**COREMO OCMEA**

fabrica frenos y embragues de accionamiento mecánico, neumático e hidráulico para los sectores de alambre & cable, siderurgia, acero, textil, papel, converting, envasado y para otras aplicaciones industriales. COREMO OCMEA, fundada en 1960, tiene la sede en Assago - Milan (Italy) con una planta de 3.200 m<sup>2</sup>.

**COREMO OCMEA**

produce freni e frizioni ad azionamento meccanico, pneumatico ed idraulico per i settori del filo & cavo, lamiera, siderurgico, tessile, carta, converting, packaging ed in generale per tutte le applicazioni industriali. COREMO OCMEA, fondata nel 1960, ha sede ad Assago (MI), in uno stabilimento di 3.200 m<sup>2</sup>.

# COREMO CALIPER BRAKES

*bigger  
stronger  
faster*



## FRENI A PINZA

Classificazione

Caliper Brakes Range

Pagina

Page

## MANUALI

A comando manuale

MANUAL CONTROL

Mechanically actuated

## PNEUMATICI

Positivi

PNEUMATIC

Air actuated

## PNEUMATICI

Negativi

PNEUMATIC

Failsafe

Spring applied pneumatically released

## COMBINATI "Dual"

Positivi e Negativi

COMBINED "Dual" Air Applied & Failsafe

## INDICE

## INDEX

<b>CORRETTO UTILIZZO DEL PRODOTTO</b>	<i>CORRECT USE OF THE PRODUCT</i>	<b>2 - 3</b>
<b>SELEZIONE</b>	<i>SELECTION</i>	<b>4 - 5</b>
<b>DISCHI</b>	<i>DISCS</i>	<b>6 - 11</b>
<b>MPA-M</b>	<i>MPA-M</i>	<b>14 - 15</b>
<b>A-M</b>	<i>A-M</i>	<b>16 - 17</b>
<b>B-M</b>	<i>B-M</i>	<b>18 - 19</b>
<b>D-M</b>	<i>D-M</i>	<b>20 - 21</b>
<b>E-M</b>	<i>E-M</i>	<b>22 - 23</b>
<b>EL-M</b>	<i>EL-M</i>	<b>24 - 25</b>
<b>F-M</b>	<i>F-M</i>	<b>26 - 27</b>
<b>G-M</b>	<i>G-M</i>	<b>28 - 29</b>
<b>MICRO</b>	<i>MICRO</i>	<b>32 - 33</b>
<b>MPA MPA05 MPA1</b>	<i>MPA MPA05 MPA1</i>	<b>34 - 35</b>
<b>A05 A1 A2 A3</b>	<i>A05 A1 A2 A3</i>	<b>36 - 37</b>
<b>B05 B1 B2</b>	<i>B05 B1 B2</i>	<b>38 - 39</b>
<b>C300 C600 C1200</b>	<i>C300 C600 C1200</i>	<b>40 - 41</b>
<b>D05 D1 D2 D3</b>	<i>D05 D1 D2 D3</i>	<b>42 - 43</b>
<b>E3 E4</b>	<i>E3 E4</i>	<b>44 - 45</b>
<b>EL3 EL4</b>	<i>EL3 EL4</i>	<b>46 - 47</b>
<b>F05 F1 F2 F3</b>	<i>F05 F1 F2 F3</i>	<b>48 - 49</b>
<b>G1 G2 G3 G3.5</b>	<i>G1 G2 G3 G3.5</i>	<b>50 - 51</b>
<b>MPA-N MPA-1N</b>	<i>MPA-N MPA-1N</i>	<b>54 - 55</b>
<b>A-1N A-2N A-3N</b>	<i>A-1N A-2N A-3N</i>	<b>56 - 57</b>
<b>B-1N B-2N</b>	<i>B-1N B-2N</i>	<b>58 - 59</b>
<b>D-1N D-2N D-3N</b>	<i>D-1N D-2N D-3N</i>	<b>60 - 61</b>
<b>E-3N E-3.5N E-4N</b>	<i>E-3N E-3.5N E-4N</i>	<b>62 - 63</b>
<b>EL-3N EL-3.5N EL-4N</b>	<i>EL-3N EL-3.5N EL-4N</i>	<b>64 - 65</b>
<b>F-1N F-2N F-3N</b>	<i>F-1N F-2N F-3N</i>	<b>66 - 67</b>
<b>G-2N G-3N G-3.5N</b>	<i>G-2N G-3N G-3.5N</i>	<b>68 - 69</b>
<b>A1-2N A3-3N</b>	<i>A1-2N A3-3N</i>	<b>72 - 73</b>
<b>D1-2N D3-3N</b>	<i>D1-2N D3-3N</i>	<b>74 - 75</b>
<b>F1-2N F3-3N</b>	<i>F1-2N F3-3N</i>	<b>76 - 77</b>
<b>G1-2N G3-3N</b>	<i>G1-2N G3-3N</i>	<b>78 - 79</b>
<b>CARATTERISTICHE</b>	<i>FEATURES</i>	<b>80 - 83</b>
<b>ORGANIZZAZIONE DI VENDITA</b>	<i>WORLD WIDE COVERAGE</i>	<b>85</b>

Ci riserviamo di modificare in qualsiasi momento senza preavviso le caratteristiche tecniche, le dimensioni ed i pesi indicati nel presente catalogo. Le illustrazioni non sono impegnative.

*Technical characteristics, sizes, weights and illustrations shown in this catalogue are subject to change without prior notice.*



## **CORRETTO UTILIZZO DEL PRODOTTO**



**In ottemperanza al DPR 224/88 Direttiva CEE n. 85/374 definiamo i limiti di impiego per il corretto utilizzo del nostro prodotto garantendo la salvaguardia degli aspetti di sicurezza.**

### **Caratteristiche di progetto**

I **FRENI A PINZA** della COREMO OCMEA sono stati progettati per operare in conformità delle prestazioni e condizioni previste nel presente catalogo e delle relative specifiche tecniche. È fatto in ogni caso raccomandazione perchè tali limiti non vengano superati.

### **Selezione di applicazione**

Premessa di fondamentale importanza è una corretta selezione dell'unità da impiegare. Nella selezione bisogna tener conto di un appropriato fattore di servizio. In caso di freni di stazionamento il fattore di servizio non deve essere inferiore a 2.

L'Ufficio Tecnico della COREMO OCMEA è a disposizione per informazioni, suggerimenti e collaborazione per una corretta applicazione ed impiego.

### **Impiego**

Il rispetto delle Istruzioni di Montaggio e Manutenzione, oltre ad evitare costose soste improduttive, previene incidenti dovuti alla non completa conoscenza del prodotto.

Attenzione: la coppia iniziale può essere dal 30% al 50% in meno rispetto al valore nominale, fino all'assemblamento dei ferodi sui dischi.

### **Precauzioni al montaggio e manutenzione**

Agli addetti a tale funzione si consiglia l'impiego di equipaggiamenti idonei, guanti, occhiali od altro per la protezione adeguata da carichi e/o pesi.

### **Parti rotanti**

Le parti in movimento devono essere protette in conformità a quanto prescritto dalle Direttive 98/37/CEE e DPR 459/96 o dalle equivalenti norme vigenti nei Paesi in cui vengono utilizzate.

### **Freni negativi a molle**

I freni negativi a molle devono essere trattati con particolare attenzione, perchè contengono molle meccanicamente precaricate.

### **Materiali di attrito**

Tutti i **FRENI A PINZA** COREMO OCMEA sono equipaggiati con materiale di attrito assolutamente esente da amianto e nel pieno rispetto delle Normative e Leggi in vigore per la tutela della salute ed il rispetto dell'ambiente.

È comunque buona cosa non inalare la polvere da essi prodotta e lavarsi accuratamente le mani prima di ingerire cibi o bevande.

### **Oli, grassi e componenti lubrificanti**

Vengono impiegati in quantità estremamente limitate. Per eventuali allergie a queste sostanze si consiglia l'uso di guanti o creme protettive da asportare con accurato lavaggio delle mani prima di ingerire cibi o bevande.

### **Immagazzinamento**

Nello stoccaggio dei **FRENI A PINZA** si deve tenere conto di un'alta concentrazione di peso in poco spazio.

Si consiglia un equipaggiamento idoneo agli addetti a tale funzione (scarpe di sicurezza, caschi, guanti, etc) al fine di prevenire il rischio di incidenti.

### **Smaltimento**

Le pastiglie di attrito usurate e gli altri materiali di cui i **FRENI A PINZA** sono composti, sono classificati come prodotti **NON** Tossico-Nocivi, pertanto devono essere smaltiti in conformità e nel rispetto delle leggi vigenti nei Paesi in cui vengono prevalentemente utilizzati.

### **Stoccaggio**

I **FRENI A PINZA** della COREMO OCMEA contengono membrane e/o anelli di tenuta in gomma che in caso di incendio possono generare gas tossici. Agli addetti allo spegnimento, in ambienti di piccole dimensioni, si consiglia l'uso della maschera antigas.

## CORRECT USE OF THE PRODUCT

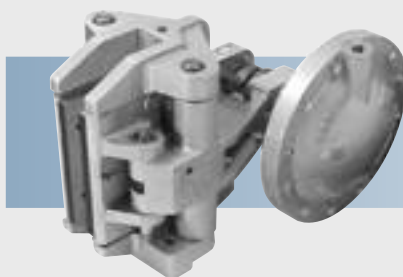

**According to EEC rules no. 85/374 we define the correct use of the product in order to comply with safety regulations.**

### **Characteristics of the design**

The COREMO OCMEA **Caliper Brakes** are designed to operate according to the application, conditions and technical specifications as set out in this catalogue. We recommend that the maximum data shown are not exceeded.

### **Application selection**

It is essential when selecting to take in consideration an appropriate service factor. In case of holding duties this factor should be not less than 2. Our Technical Department at COREMO OCMEA is available for information, suggestions and cooperation for the correct application and use.

### **Use**

The Mounting and Maintenance Instructions must be observed so as to prevent accidents, breakage etc. Incorrect mounting and maintenance of the unit could also result in reduced life of the product and expensive down time. **Warning:** the initial torque on new units can be 30% to 50% less than the catalogue value until the linings are settled on the discs.

### **Precautions for the mounting and maintenance**

Operators are advised to wear the correct protective clothing such as gloves, safety glasses, etc.

### **Rotating parts**

The moving parts have to be protected according to the European EEC directives no. 98/37, or the equivalent norms effective in the Countries where they are used.

### **Spring applied failsafe brakes**

Failsafe brakes must be treated with special attention because they have mechanical pre-tensioned springs.

### **Friction parts**

All the COREMO OCMEA **Caliper Brakes** are supplied with non asbestos friction material which is in accordance to the Health and Safety regulations. Even though the linings are asbestos free you should not breathe in the dust produced from the brake linings and if in contact ensure that the hands are clean before eating or drinking.

### **Oils, greases and lubricating components**

Although used in very small quantities we advise those persons who have allergies to use protective creams when maintaining our units and ensuring that the hands are washed before eating or drinking.

### **Storage**

When storing or handling **Caliper Brakes** the weight of the product must be observed to ensure correct and safe storage and lifting.

We advise that you use the correct protective clothing, safety shoes, helmets, gloves, etc. so as to prevent the risk of accident.

### **Disposing**

All worn linings and other materials used in our **Caliper Brakes** are classified as **NON** Toxic-Harmful products, therefore they must be disposed according to the industrial rules and laws of the Country where they are used.

### **Stocking**

The COREMO OCMEA **Caliper Brakes** contain rubber diaphragms and seals; in case of fire they can generate toxic gases, therefore the Fire Brigade or Internal Fire Personnel must use the correct masks when extinguishing.



## SELEZIONE

### SLITTAMENTO CONTINUO

DOVE

<b>C</b>	Coppia dinamica	Nm
<b>T</b>	Tensione sul materiale	N
<b>D</b>	Diametro min e/o max della bobina	m
<b>V</b>	Velocità lineare	m/min
<b>Qc</b>	Calore prodotto in continuo	kW
<b>n</b>	Velocità di rotazione	min <sup>-1</sup>

$$C = \frac{T \cdot D}{2}$$

$$Qc = \frac{T \cdot V}{60 \cdot 10^3}$$

$$n = \frac{V}{\pi \cdot D}$$

### FRENATURA DI INERZIE ELEVATE

FRENATURA DI EMERGENZA

DOVE

<b>C</b>	Coppia dinamica	Nm
<b>J</b>	Inerzia	kgm <sup>2</sup>
<b>n</b>	Velocità di rotazione	min <sup>-1</sup>
<b>t</b>	Tempo di frenatura	s
<b>Q</b>	Calore prodotto/frenata	kW

$$C = \frac{J \cdot n}{9.55 \cdot t}$$

$$Q = \frac{J \cdot n^2}{182.5 \cdot 10^3 \cdot t}$$

### FRENATURA CICLICA

DOVE

<b>C</b>	Coppia dinamica	Nm
<b>J</b>	Inerzia	kgm <sup>2</sup>
<b>n</b>	Velocità di rotazione	min <sup>-1</sup>
<b>t</b>	Tempo di frenatura	s
<b>Q</b>	Calore prodotto/frenata	kW
<b>Qc</b>	Calore prodotto in continuo	kW
<b>s</b>	Interventi/minuto	

$$C = \frac{J \cdot n}{9.55 \cdot t}$$

$$Q = \frac{J \cdot n^2}{182.5 \cdot 10^3 \cdot t}$$

$$Qc = \frac{Q \cdot s \cdot t}{60}$$

Tutti i valori relativi alla dissipazione di calore, riportati in questo catalogo, sono riferiti a  $\Delta T = 170 \text{ }^\circ\text{C}$

Richiedeteci la selezione per il freno più idoneo

## SELECTION

### TENSIONING

WHERE

<b>C</b>	Dynamic torque	Nm
<b>T</b>	Web tension	N
<b>D</b>	Min and/or max roll diameter	m
<b>V</b>	Web speed	m/min
<b>Qc</b>	Heat (continuous)	kW
<b>n</b>	Rotating speed	min <sup>-1</sup>

### HIGH INERTIA STOP

EMERGENCY STOP

WHERE

<b>C</b>	Dynamic torque	Nm
<b>J</b>	Total inertia load	kgm <sup>2</sup>
<b>n</b>	Rotating speed	min <sup>-1</sup>
<b>t</b>	Time	s
<b>Q</b>	Heat/each stop	kW

### CYCLIC STOP

WHERE

<b>C</b>	Dynamic torque	Nm
<b>J</b>	Total inertia load	kgm <sup>2</sup>
<b>n</b>	Rotating speed	min <sup>-1</sup>
<b>t</b>	Time	s
<b>Q</b>	Heat/each stop	kW
<b>Qc</b>	Heat continuous	kW
<b>s</b>	Stops/minute	

All the data, shown on this catalogue, regarding thermal capacity are referred to  $\Delta T = 170 \text{ }^\circ\text{C}$

To select your proper brake consult our technical office



## Slittamento continuo

### Tensioning

- Tiro totale	2420 N	<i>total tension</i>
- Velocità	40 m/min	<i>linear speed</i>
- Diametro massimo bobina	1.5 m	<i>max. coil dia</i>
- Diametro minimo bobina	0.56 m	<i>min. coil dia</i>
- Coppia massima	$\frac{2400 \times 1.5}{2} = 1800 \text{ Nm}$	<i>max torque</i>
- Coppia minima	$\frac{2400 \times 0.56}{2} = 672 \text{ Nm}$	<i>min torque</i>
- Velocità di rotazione massima	$\frac{40}{\pi \times 0.56} = 22.7 \text{ min}^{-1}$	<i>max rotating speed</i>
- Velocità di rotazione minima	$\frac{40}{\pi \times 1.5} = 8.5 \text{ min}^{-1}$	<i>min rotating speed</i>
- Calore da dissipare	$\frac{2400 \times 40}{60 \times 10^3} = 1.6 \text{ kW}$	<i>continuous mean power</i>

## Selezione

### Selection

<b>N°1 freno tipo D2 con disco diametro 610 mm</b>		<i>No.1 brake D2 with 610 mm dia disc</i>
- Coppia a 6 bar	2040 Nm	<i>torque at 6 bar</i>
- Capacità termica del freno	3.4 kW	<i>brake thermal capacity</i>
- Capacità termica del disco a 13.35 min <sup>-1</sup>	2.4 kW	<i>disc thermal capacity at 13.35 min<sup>-1</sup></i>
- Temperatura teorica del disco a temperatura ambiente (20 °C)	113 °C + 20 °C = 133 °C	<i>estimate disc surface temperature at ambient temperature (20 °C)</i>

## Frenata di emergenza

### Emergency stop

- Inerzia da frenare	486 kgm <sup>2</sup>	<i>total inertia</i>
- Velocità di rotazione	250 min <sup>-1</sup>	<i>rotating speed</i>
- Tempo di frenatura	3 s	<i>braking time</i>
- Tipo di freno: negativo		<i>type of brake: failsafe</i>
- Coppia di frenatura	$\frac{486 \times 250}{9.55 \times 3} = 4241 \text{ Nm}$	<i>braking torque</i>
- Calore prodotto ad ogni frenata	$\frac{486 \times 250^2}{182.5 \times 10^3 \times 3} = 55.5 \text{ kW}$	<i>mean braking power</i>

## Selezione

### Selection

<b>N°2 freni D-3N con 1 disco diametro 514 mm</b>		<i>No.2 brakes D-3N with 1 disc dia. 514 mm</i>
- Coppia di frenatura	2330 Nm x 2 = 4660 Nm	<i>braking torque</i>
- Capacità termica del freno	84 kW x 2 = 168 kW	<i>brake thermal capacity</i>
- Capacità termica del disco	176 kW	<i>disc thermal capacity</i>

VERIFICA		VERIFICATION
- Tempo di frenatura	$\frac{486 \times 250}{9.55 \times 4660} = 2.73 \text{ s}$	<i>braking time</i>
- Calore prodotto ad ogni frenata	$\frac{486 \times 250^2}{182.5 \times 10^3 \times 2.73} = 61 \text{ kW}$	<i>mean braking power</i>
Temperatura teorica del disco a temperatura ambiente (20 °C)	59 °C + 20 °C = 79 °C	<i>estimate disc surface temperature at ambient temperature (20 °C)</i>

# Dischi

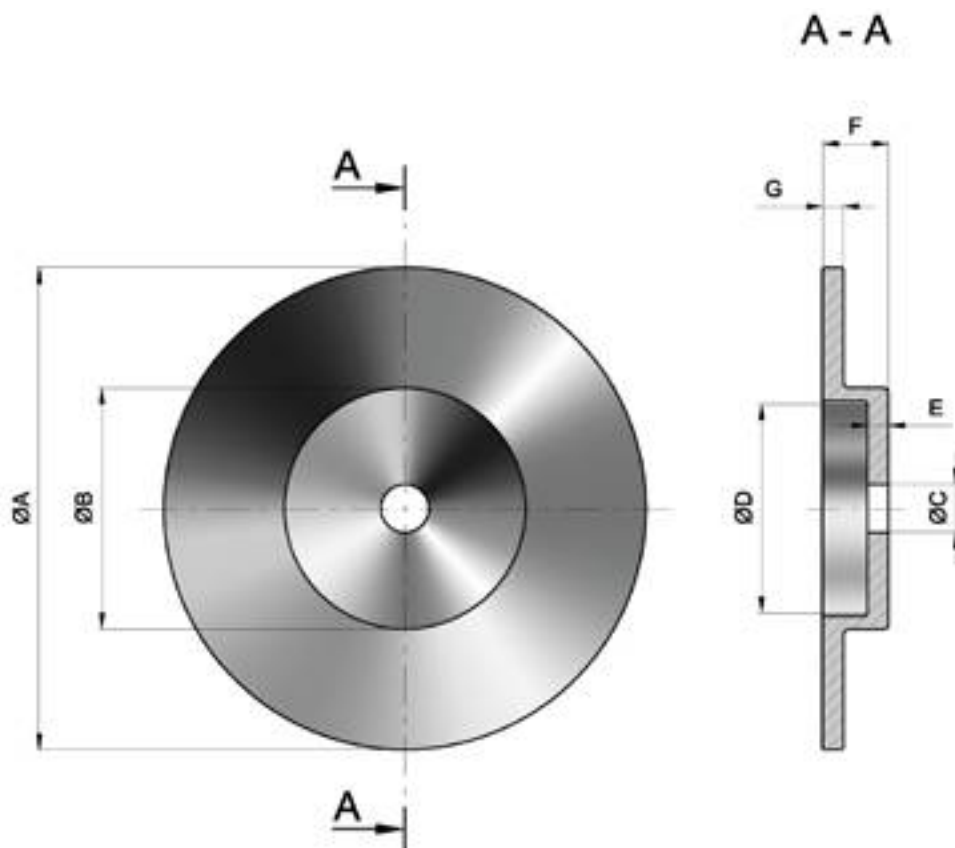

## DIMENSIONI/DIMENSIONS



TIPO SIZE	Cod. Prodotto Product Number	Ø A	Ø B	Ø C grezzo rough bore	Ø D	E	F	G	Inerzia Inertia	Max Velocità Max speed	Peso Weight
DISCO DISC	A 1302	250	128	20	116	6	36	12.7	0.08	4500	4.2
	A 1303	300	181	30	161	13	41	12.7	0.12	3800	7.3
	A 1311 *	300	150	30	130	13	41	12.7	0.10	3800	7.2
	A 1304	356	210	40	171	16	54	12.7	0.23	3200	12.5
	A 1305	406	260	44	234	16	54	12.7	0.33	2800	15
	A 1306	457	311	44	273	16	54	12.7	0.53	2500	21
	A 1307	514	368	44	336	16	54	12.7	0.83	2200	25
	A 1308	610	464	44	422	16	54	12.7	1.63	1850	37.5
	A 1309	711	565	80	528	19	54	12.7	3.36	1400	55
	A 3158	610	343	50	280	38	76	25.4	2.9	1850	68
	A 3159	762	495	100	431	38	76	25.4	7.4	1500	109
	A 3160	914	648	100	577	38	76	25.4	16	1250	162
	A 3161	1065	800	100	730	38	76	25.4	30	1100	225

\* Per freno tipo D e F \* For D and F caliper brake

# Capacità termica in continuo

## Continuous thermal capacity

**Dischi spessore 12.7 mm.**  
*Disc thickness 12.7 mm.*

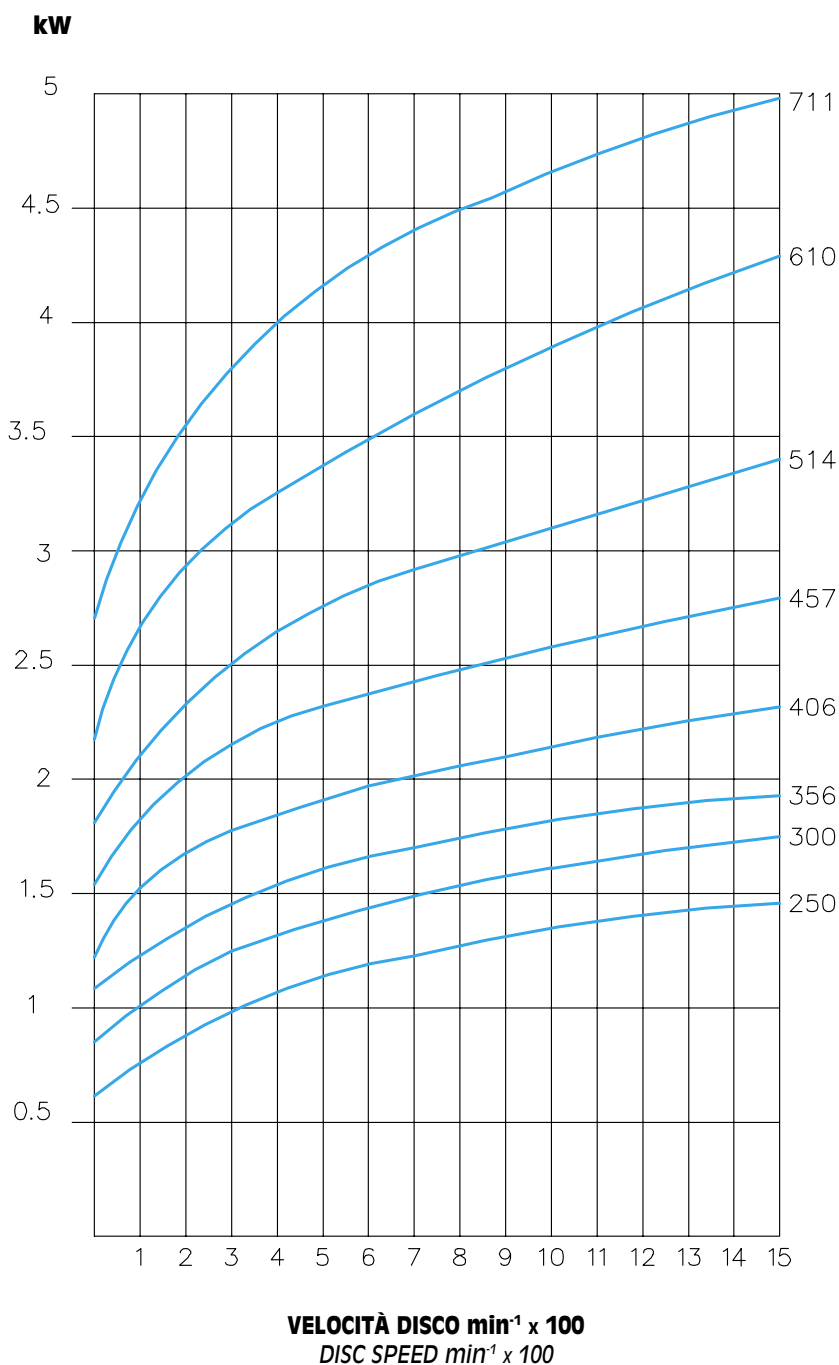

# Discs

## Dati tecnici

**GHISA SFEROIDALE**

**UNI-ISO 1083 - 500.7**

## Technical data

**SG IRON**

**UNI-ISO 1083 - 500.7**

**DISSIPAZIONE DI CALORE IN CONTINUO  
CON  $\Delta T = 170^{\circ}\text{C}$**

**CONTINUOUS  
THERMAL CAPACITY  
WITH  $\Delta T = 170^{\circ}\text{C}$**

**Spessore 12.7 mm.**

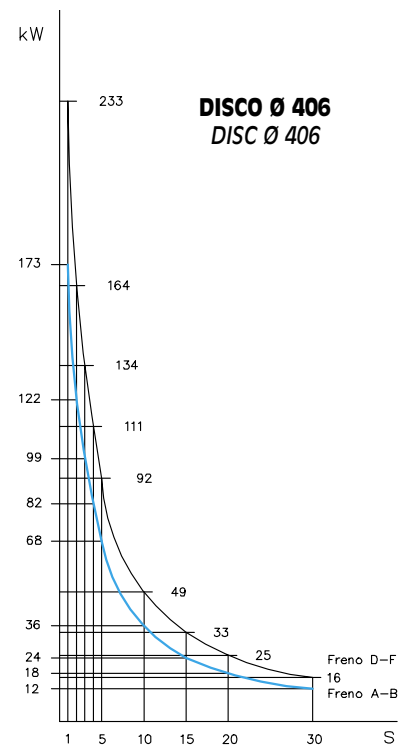
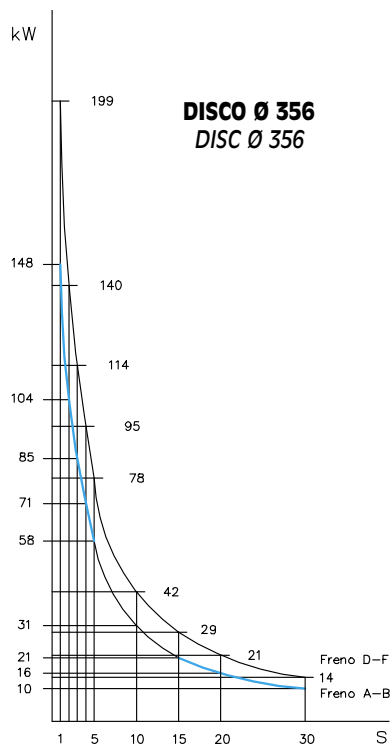
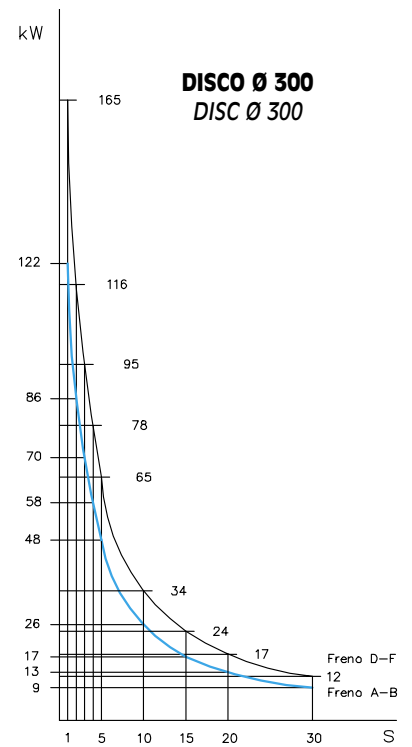
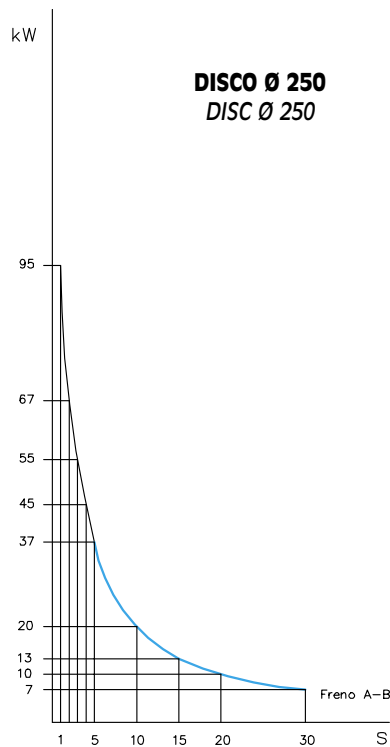

Thickness 12.7 mm.

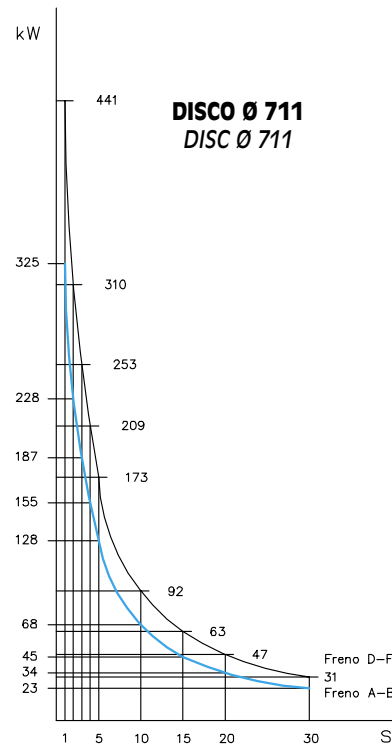
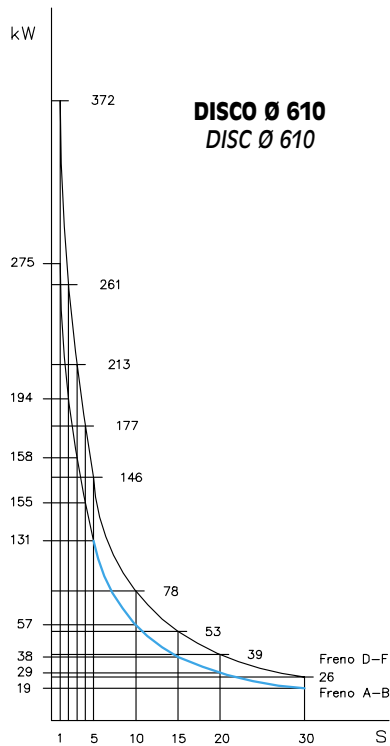
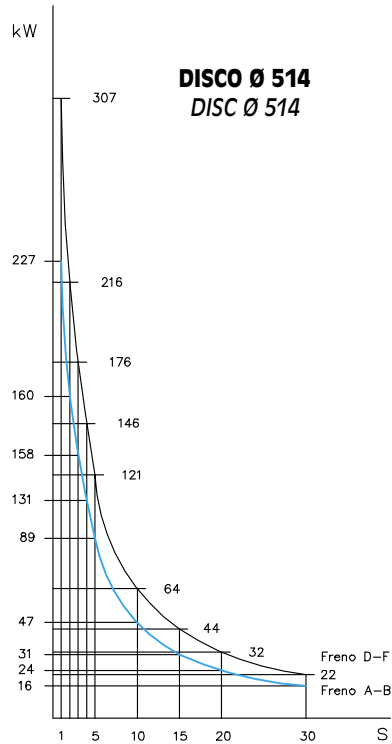
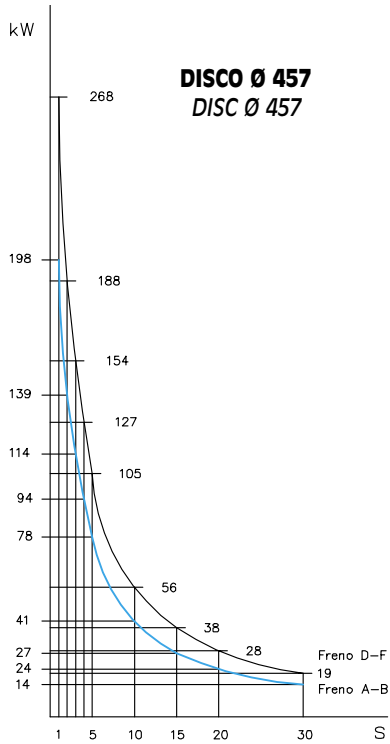

**DISSIPAZIONE DI CALORE  
PER FRENATURA  
DI EMERGENZA  
CON  $\Delta T = 170^\circ C$**   
**THERMAL CAPACITY  
FOR EMERGENCY STOP  
WITH  $\Delta T = 170^\circ C$**

# Dischi

**Dischi spessore 25.4 mm**  
*Discs thickness 25.4 mm*

## Dati tecnici

**GHISA SFEROIDALE**

**UNI-ISO 1083 - 500.7**

## Technical data

**SG IRON**

**UNI-ISO 1083 - 500.7**

**DISSIPAZIONE DI  
CALORE IN CONTINUO  
CON  $\Delta T = 170^{\circ}\text{C}$**

**CONTINUOUS  
THERMAL CAPACITY  
WITH  $\Delta T = 170^{\circ}\text{C}$**

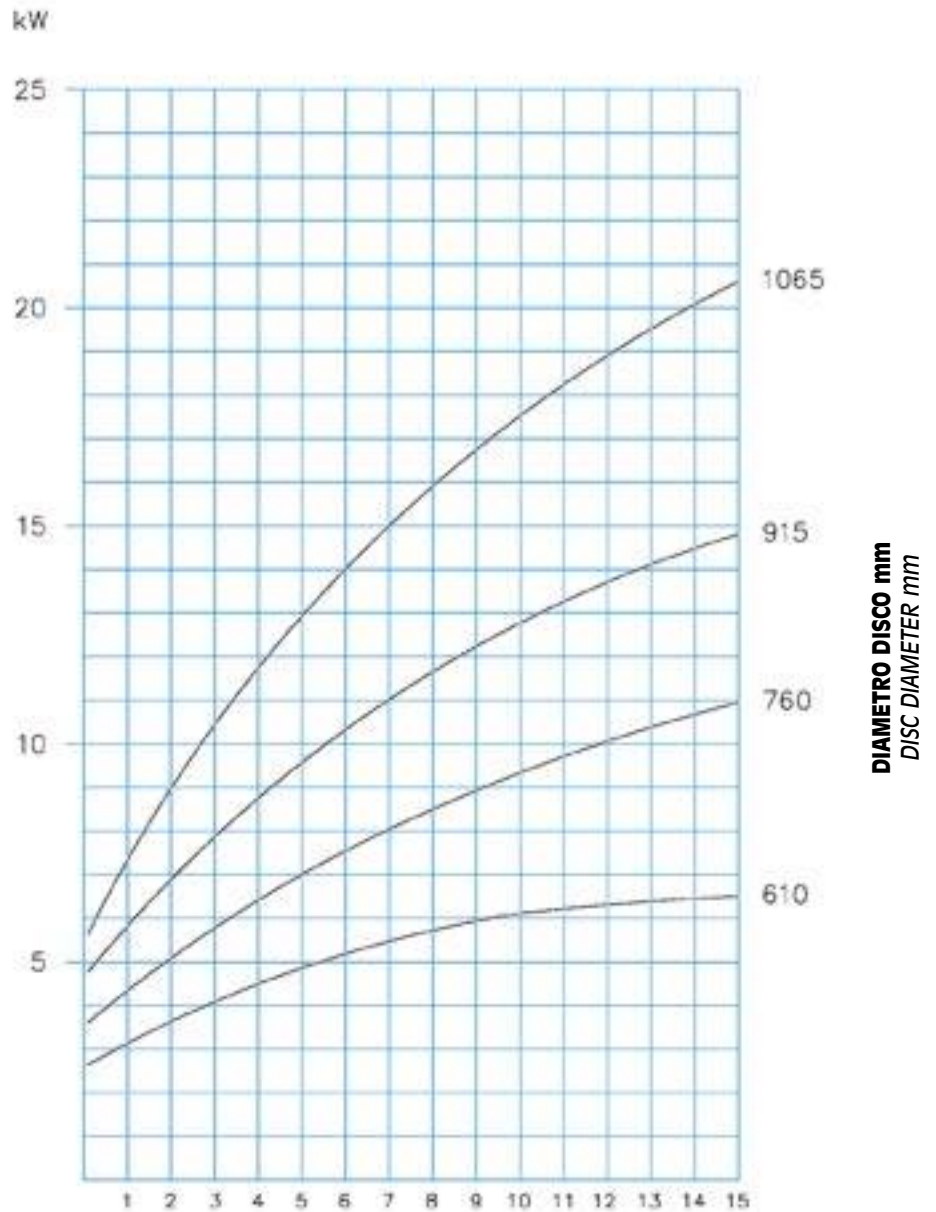

**VELOCITÀ DISCO  $\text{min}^{-1} \times 100$**   
*DISC SPEED  $\text{min}^{-1} \times 100$*

**DIAMETRO DISCO mm**  
*DISC DIAMETER mm*

# Capacità termica frenata d'emergenza

Thermal capacity - Emergency stop

**Dischi spessore 25.4 mm**  
Discs thickness 25.4 mm

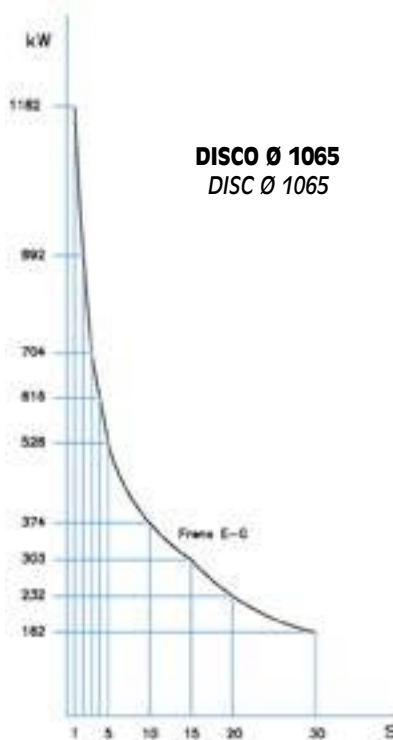
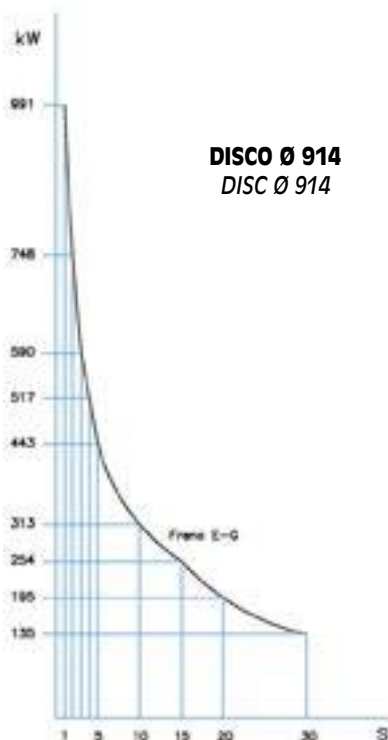
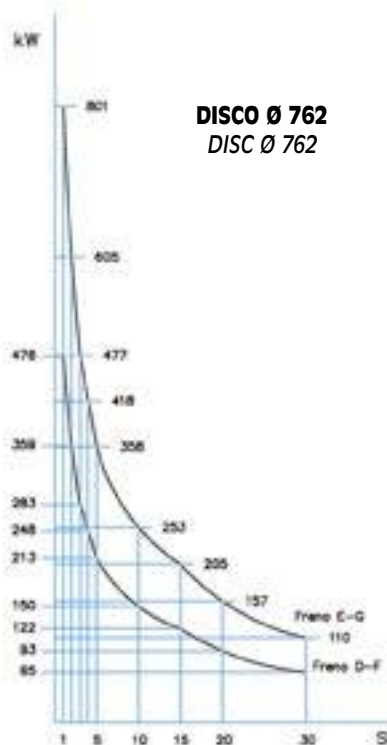
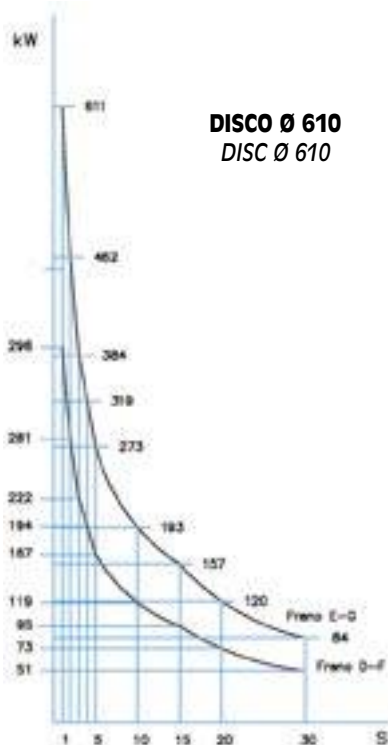

# DISCS



**DISSIPAZIONE DI CALORE  
PER FRENATURA  
DI EMERGENZA  
CON  $\Delta T = 170^{\circ}\text{C}$**   
**THERMAL CAPACITY  
FOR EMERGENCY STOP  
WITH  $\Delta T = 170^{\circ}\text{C}$**



# MANUALE

## A comando manuale

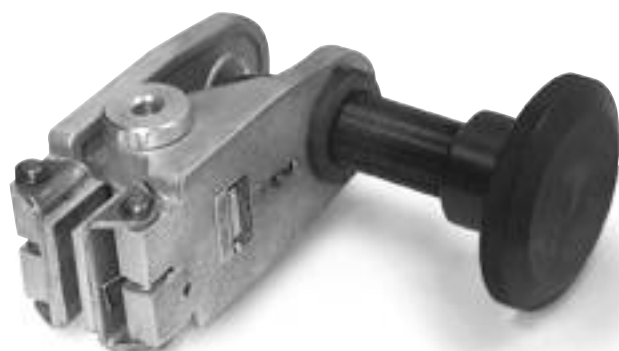

# MANUAL CONTROL

## *Mechanically actuated*

**La serie dei freni a pinza a comando manuale rappresenta un'ottima soluzione per macchine semplici in cui è necessaria una frenatura non regolabile in modo continuo. Inoltre permette il montaggio di un freno nel caso non fosse disponibile l'aria compressa.**

*Mechanically actuated brakes are the best solution for simple machines where it is not necessary a continuous brake tuning. Besides, if air supply is not available, it is possible to mount a brake.*



# MPA-M

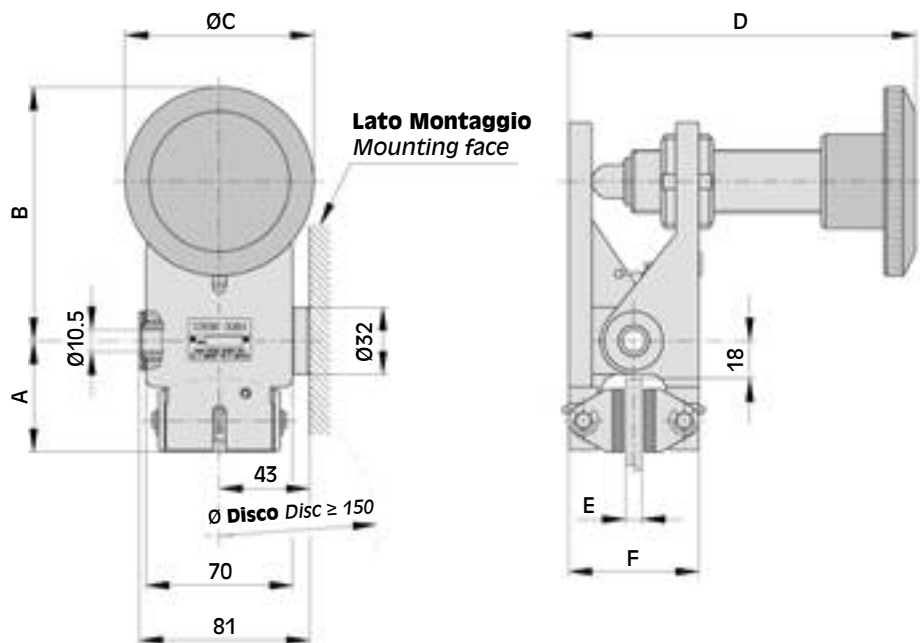

## DIMENSIONI/DIMENSIONS



TIPO SIZE	Cod. Prodotto Product Number	A	B	ØC	D	E	F	Peso Weight kg
MPA-M	A2912	53	121	90	166	8	62	2.4
	A2914	51	129	90	175	12.7	68	2.4

**Attenzione:** La coppia iniziale può essere dal 30% al 50% in meno rispetto al valore nominale, fino all'assestamento del ferodo sul disco.

**Warning:** The initial torque on new units can be 30% to 50% less than the catalogue value until the friction facing and friction disc are lapped or worn in.

## Dati tecnici

Forza tangenziale F:

**MPA-M** 2880 N 12 giri del volante

Coppia dinamica  
 $= F \cdot (\text{raggio del disco in m} - 0.024) = \text{Nm}$

Usura max totale: 6 mm

Spessore del ferodo nuovo: 5 mm

Dissipazione del calore in continuo  
 Qc: 1 kW

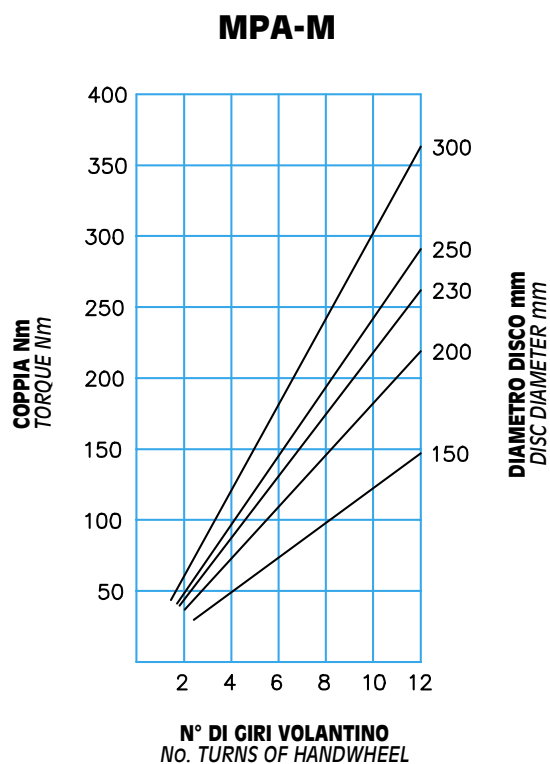

## Technical data

Braking force F:

**MPA-M** 2880 N 12 turns of handwheel

Dynamic torque  
 $= F \cdot (\text{disc radius in m} - 0.024) = \text{Nm}$

Max total wear: 6 mm

Thickness of new lining: 5 mm

Continuous thermal capacity  
 Qc: 1 kW

# A-M



**Disponibile anche per disco spessore 25,4 mm.**  
*Available also for disc thickness 25,4 mm.*

**Versione pattino doppio**  
*Double pad version*

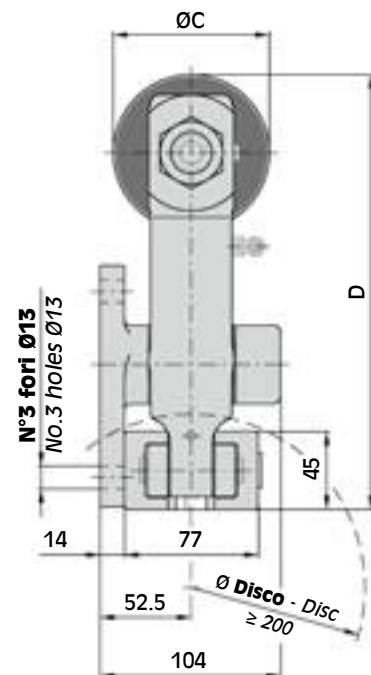
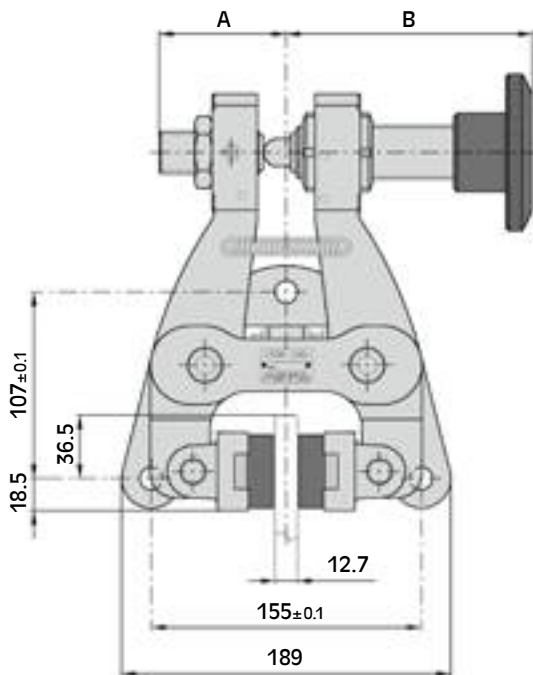
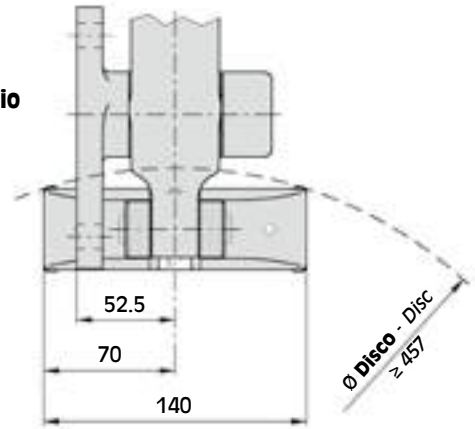

## DIMENSIONI/DIMENSIONS



TIPO SIZE	Cod. Prodotto Product Number	A	B	ØC	D	Peso Weight kg
A-M	A3254	73	141	90	250.5	11.2

**Attenzione:** La coppia iniziale può essere dal 30% al 50% in meno rispetto al valore nominale, fino all'assestamento del ferodo sul disco.

**Warning:** The initial torque on new units can be 30% to 50% less than the catalogue value until the friction facing and friction disc are lapped or worn in.

## Dati tecnici

Forza tangenziale F:

**A-M** 2880 N 12 giri del volante

Coppia dinamica  
 $= F \cdot (\text{raggio del disco in m} - 0.03) = \text{Nm}$

Usura max totale: 16 mm

Spessore del ferodo nuovo: 16 mm

Dissipazione di calore in continuo  
 Qc: 1.7 kW

Dissipazione di calore in continuo  
 con pattino doppio  
 Qc: 2.7 kW

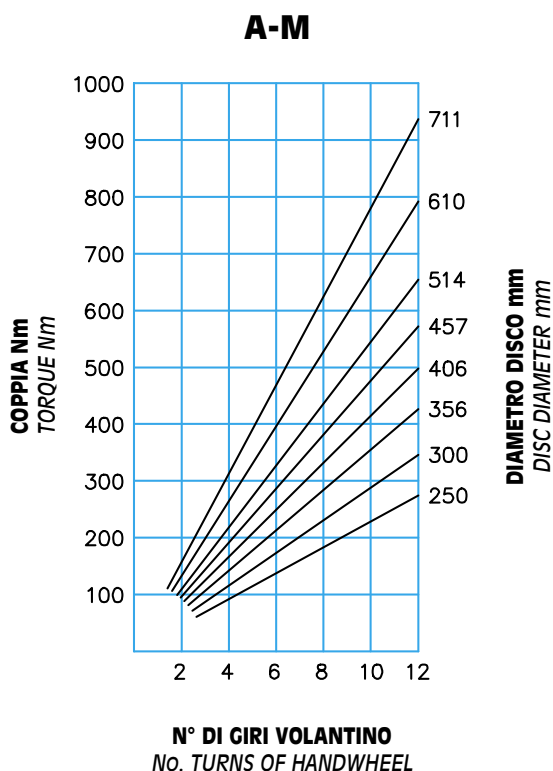

## Technical data

Braking force F:

**A-M** 2880 N 12 turns of handwheel

Dynamic torque  
 $= F \cdot (\text{disc radius in m} - 0.03) = \text{Nm}$

Max total wear: 16 mm

Thickness of new lining: 16 mm

Continuous thermal capacity  
 Qc: 1.7 kW

Continuous thermal capacity  
 for double pad version  
 Qc: 2.7 kW

## B-M



**Versione pattino doppio**  
Double pad version

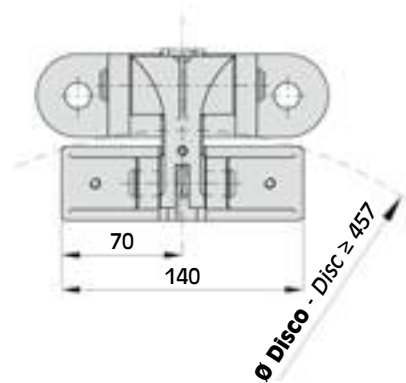

**Il freno deve essere montato in posizione orizzontale in modo che il pistone non gravi sulle leve. Per posizioni diverse consultare il nostro ufficio tecnico.**

*The brake must be mounted horizontally so that the piston does not press the brake arms. For different mounting please contact our technical office.*

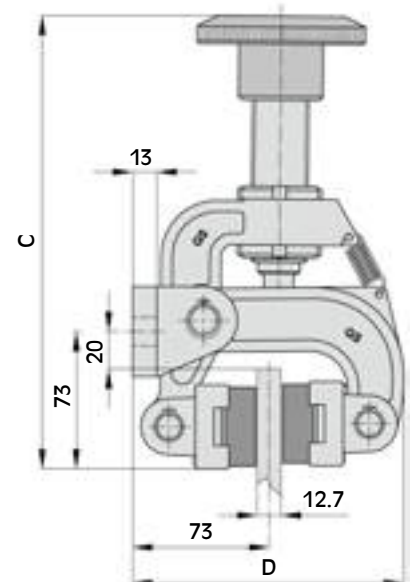
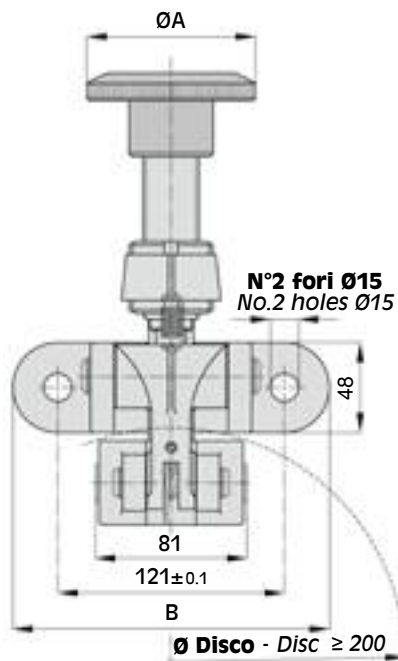

## DIMENSIONI/DIMENSIONS



TIPO SIZE	Cod. Prodotto Product Number	ØA	B	C	D	Peso Weight kg
B-M	A2012	90	169	242	145	5.6

**Attenzione:** La coppia iniziale può essere dal 30% al 50% in meno rispetto al valore nominale, fino all'assestamento del ferodo sul disco.

**Warning:** The initial torque on new units can be 30% to 50% less than the catalogue value until the friction facing and friction disc are lapped or worn in.

## Dati tecnici

Forza tangenziale F:

**B-M** 1166 N 12 giri del volante

Coppia dinamica  
 $= F \cdot (\text{raggio del disco in m} - 0.032) = \text{Nm}$

Usura max totale: 14 mm

Spessore del ferodo nuovo: 16 mm

Dissipazione del calore in continuo  
 Qc: 1.7 kW

Dissipazione di calore in continuo  
 con pattino doppio  
 Qc: 2.7 kW

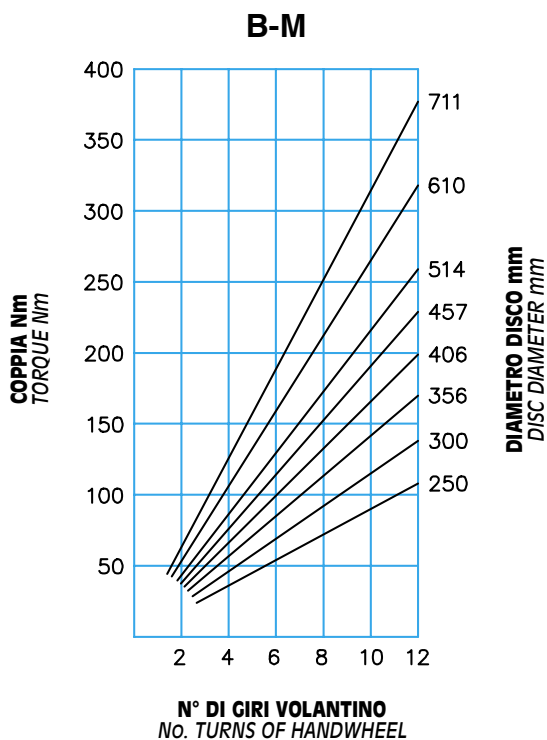

## Technical data

Braking force F:

**B-M** 1166 N 12 turns of handwheel

Dynamic torque  
 $= F \cdot (\text{disc radius in m} - 0.032) = \text{Nm}$

Max total wear: 14 mm

Thickness of new lining: 16 mm

Continuous thermal capacity  
 Qc: 1.7 kW

Continuous thermal capacity  
 for double pad version  
 Qc: 2.7 kW

## D-M

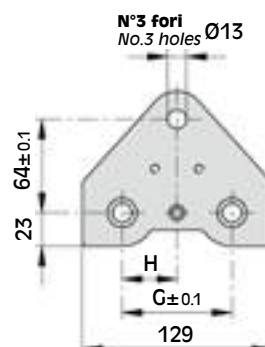

Vista base di montaggio  
View on caliper base

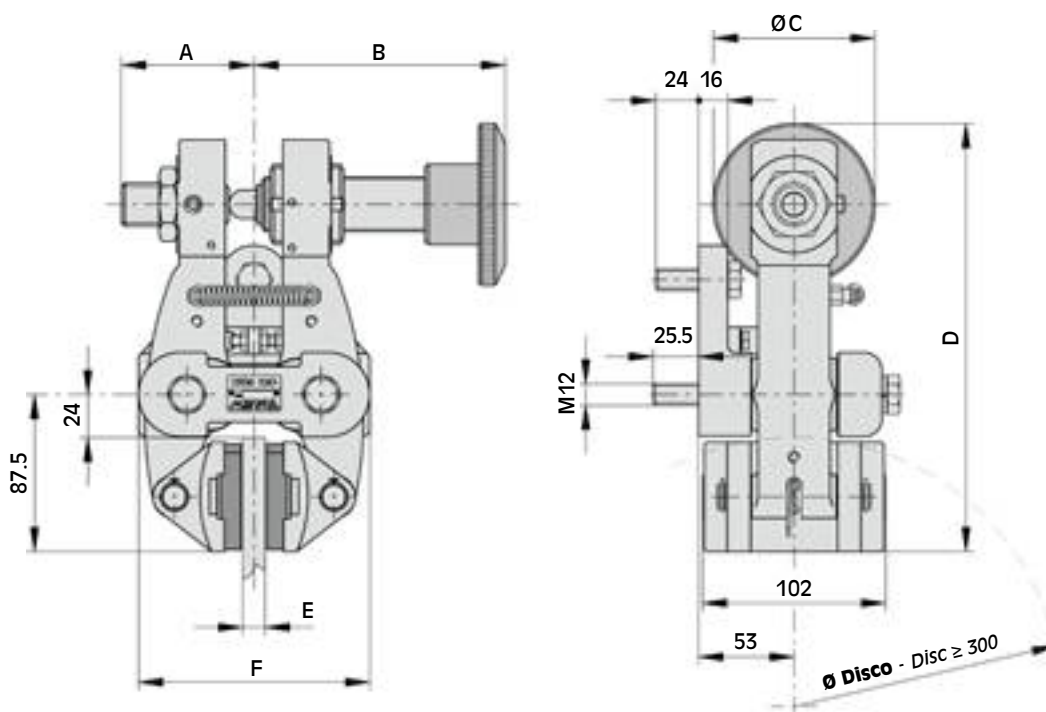

### DIMENSIONI/DIMENSIONS



TIPO SIZE	Cod. Prodotto Product Number	A	B	ØC	D	E	F	G	H	Peso Weight kg
D-M	A2366	74	140	90	238.5	12.7	129	75	37.5	9.9
	A2374	73.5	142	90	241.5	25.4	132	84	42	9.9
	A2382	85	149	90	238.5	30	140	75	37.5	9.9
	A2390	81.5	154	90	238.5	40	149	84	42	9.9

**Attenzione:** La coppia iniziale può essere dal 30% al 50% in meno rispetto al valore nominale, fino all'assestamento del ferodo sul disco.

**Warning:** The initial torque on new units can be 30% to 50% less than the catalogue value until the friction facing and friction disc are lapped or worn in.

## Dati tecnici

Forza tangenziale F:

**D-M** 2670 N 12 giri del volante

Coppia dinamica  
 $= F \cdot (\text{raggio del disco in m} - 0.033) = \text{Nm}$

Usura max totale: 12 mm

Spessore del ferodo nuovo: 11 mm

Dissipazione del calore in continuo  
 Qc: 3.4 kW

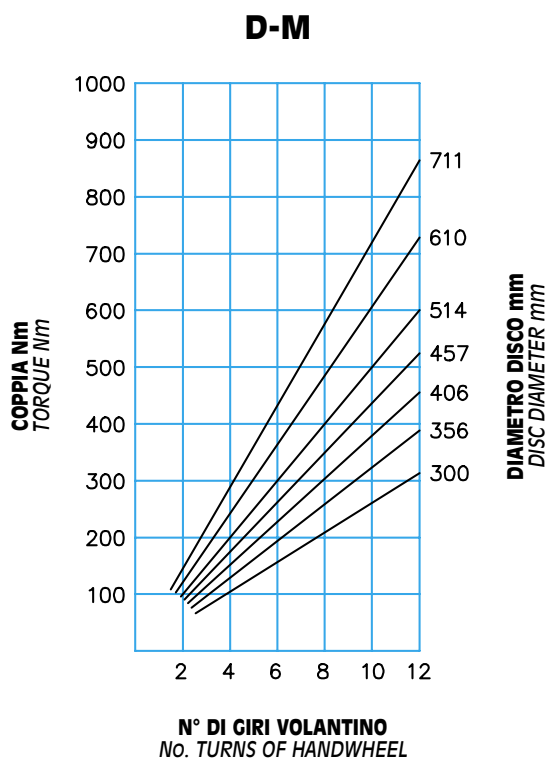

## Technical data

Braking force F:

**D-M** 2670 N 12 turns of handwheel

Dynamic torque  
 $= F \cdot (\text{disc radius in m} - 0.033) = \text{Nm}$

Max total wear: 12 mm

Thickness of new lining: 11 mm

Continuous thermal capacity  
 Qc: 3.4 kW

## E-M

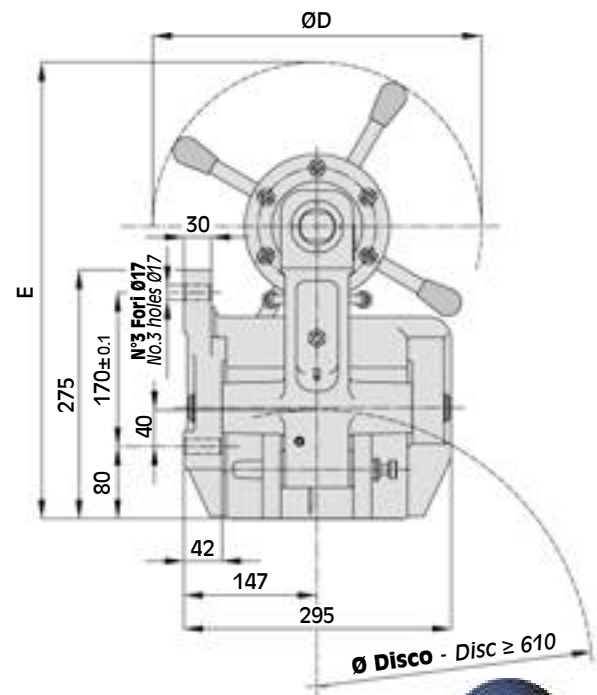
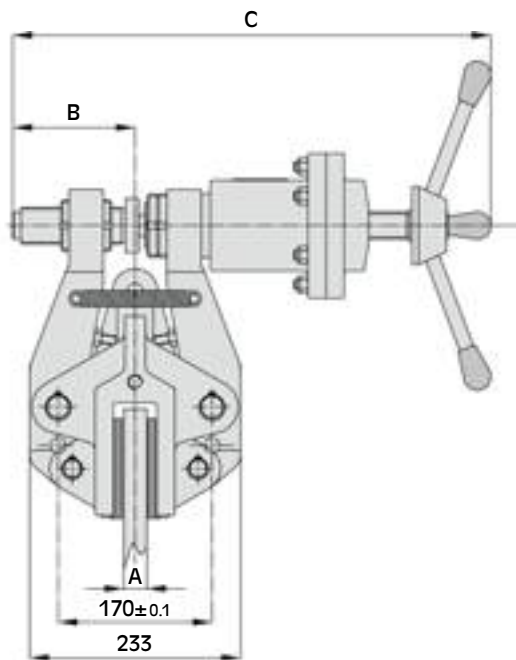

### DIMENSIONI/DIMENSIONS



TIPO SIZE	Cod. Prodotto Product Number	A	B	C	ØD	E	Peso Weight kg
E-M	A1979	25.4	135	528	363	504	69
	A1985	40	135	528	363	504	69

**Attenzione:** La coppia iniziale può essere dal 30% al 50% in meno rispetto al valore nominale, fino all'assestamento del ferodo sul disco.

**Warning:** The initial torque on new units can be 30% to 50% less than the catalogue value until the friction facing and friction disc are lapped or worn in.

## Dati tecnici

Forza tangenziale F:

**E-M** 39800 N 16 giri del volante

Coppia dinamica  
 $= F \cdot (\text{raggio del disco in m} - 0.065) = \text{Nm}$

Usura max totale: 12 mm

Spessore del ferodo nuovo: 13 mm

Dissipazione del calore in continuo  
 Qc: 20 kW

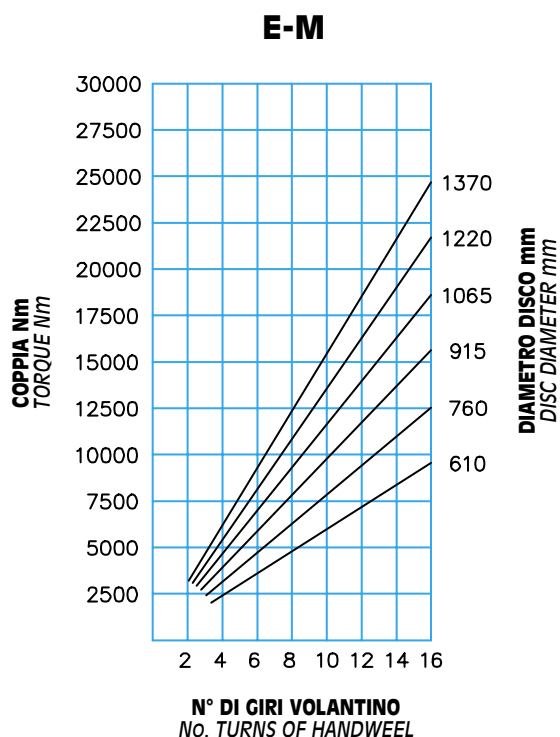

## Technical data

Braking force F:

**E-M** 39800 N 16 turns of handwheel

Dynamic torque  
 $= F \cdot (\text{disc radius in m} - 0.065) = \text{Nm}$

Max total wear: 12 mm

Thickness of new lining: 13 mm

Continuous thermal capacity  
 Qc: 20 kW

## EL-M



Vista montaggio frontale  
frontal mounting view

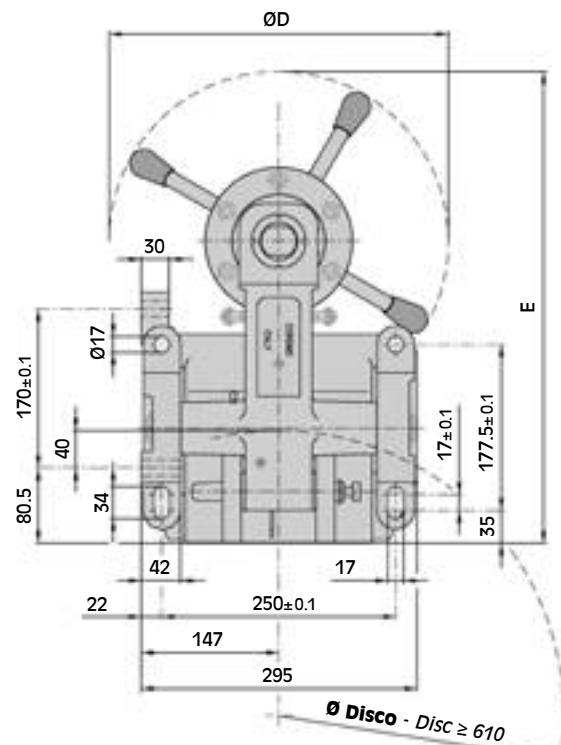
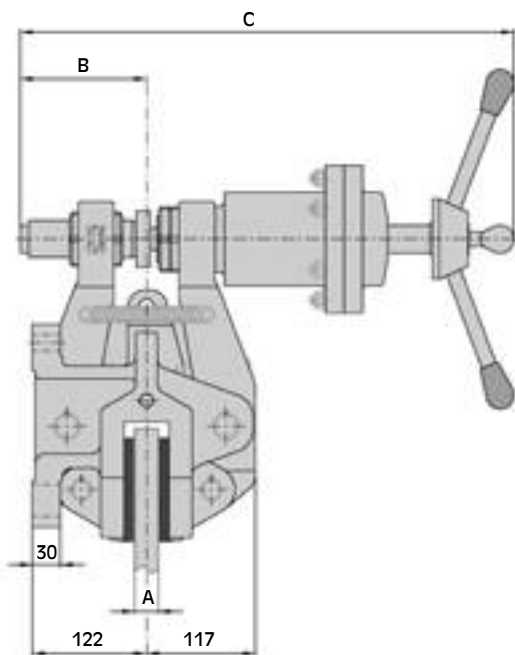
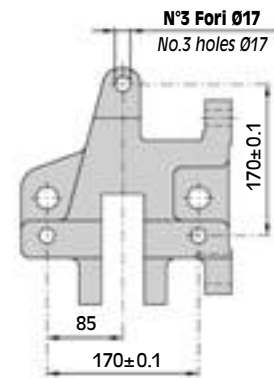

## DIMENSIONI/DIMENSIONS



TIPO SIZE	Cod. Prodotto Product Number	A	B	C	ØD	E	Peso Weight kg
EL-M	A3622	25.4	135	528	363	504	72
	A3625	40	135	528	363	504	72

**Attenzione:** La coppia iniziale può essere dal 30% al 50% in meno rispetto al valore nominale, fino all'assestamento del ferodo sul disco.

**Warning:** The initial torque on new units can be 30% to 50% less than the catalogue value until the friction facing and friction disc are lapped or worn in.

## Dati tecnici

Forza tangenziale F:

**EL-M** 39800 N 16 giri del volante

Coppia dinamica  
 $= F \cdot (\text{raggio del disco in m} - 0.065) = \text{Nm}$

Usura max totale: 12 mm

Spessore del ferodo nuovo: 13 mm

Dissipazione del calore in continuo  
 Qc: 20 kW

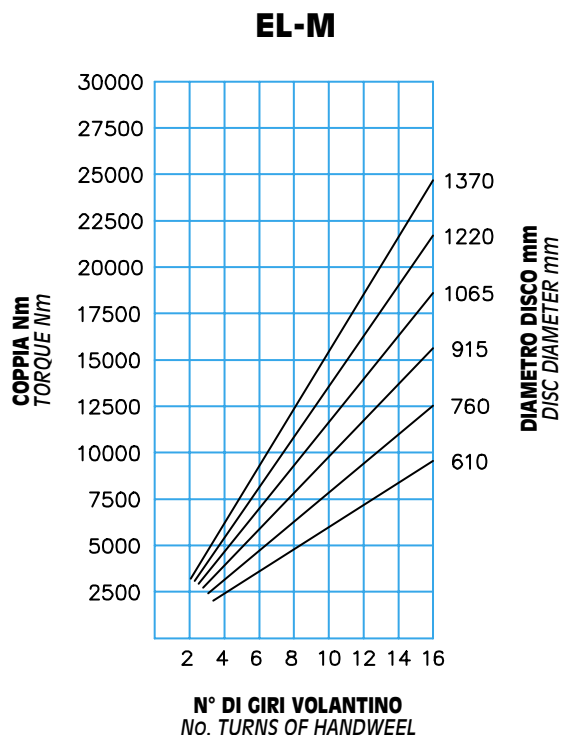

## Technical data

Braking force F:

**EL-M** 39800 N 16 turns of handwheel

Dynamic torque  
 $= F \cdot (\text{disc radius in m} - 0.065) = \text{Nm}$

Max total wear: 12 mm

Thickness of new lining: 13 mm

Continuous thermal capacity  
 Qc: 20 kW

# F-M

**Disponibile anche per disco spessore 25,4 - 30 - 40 mm.**  
*Available also for disc thickness 25,4 - 30 - 40 mm.*

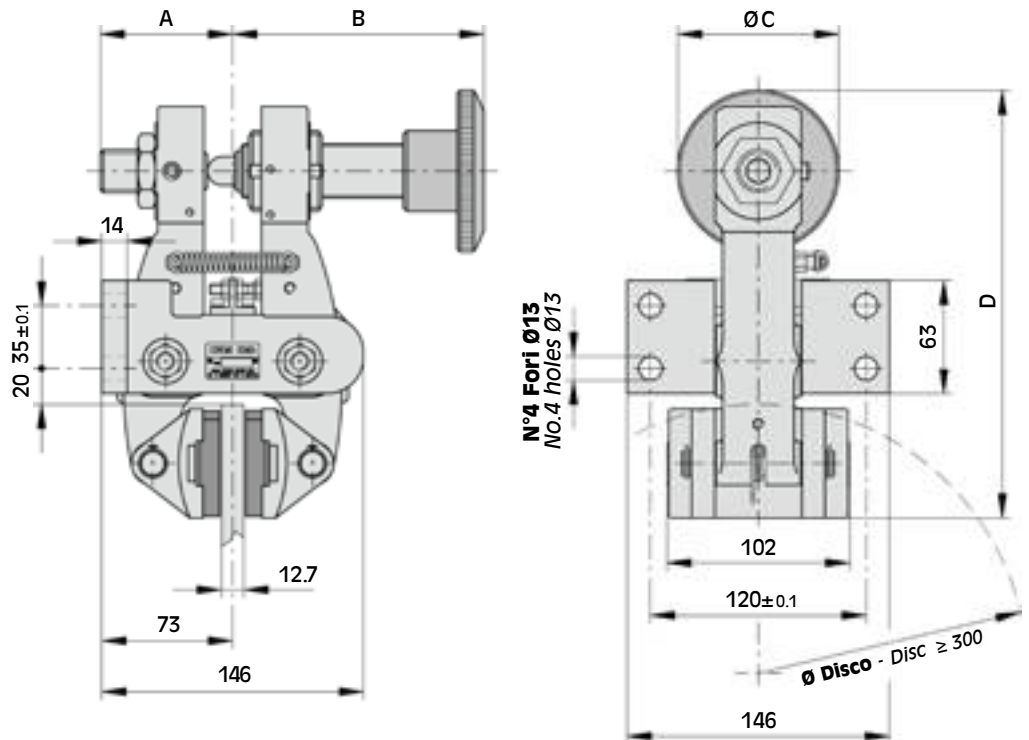

## DIMENSIONI/DIMENSIONS



TIPO SIZE	Cod. Prodotto Product Number	A	B	ØC	D	Peso Weight kg
F-M	A2750	74	140	90	238.5	9.6

**Attenzione:** La coppia iniziale può essere dal 30% al 50% in meno rispetto al valore nominale, fino all'assestamento del ferodo sul disco.

**Warning:** The initial torque on new units can be 30% to 50% less than the catalogue value until the friction facing and friction disc are lapped or worn in.

## Dati tecnici

Forza tangenziale F:

**F-M** 2670 N 12 giri del volanteCoppia dinamica  
=  $F \cdot (\text{raggio del disco in m} - 0.033) = \text{Nm}$ 

Usura max totale: 12 mm

Spessore del ferodo nuovo: 11 mm

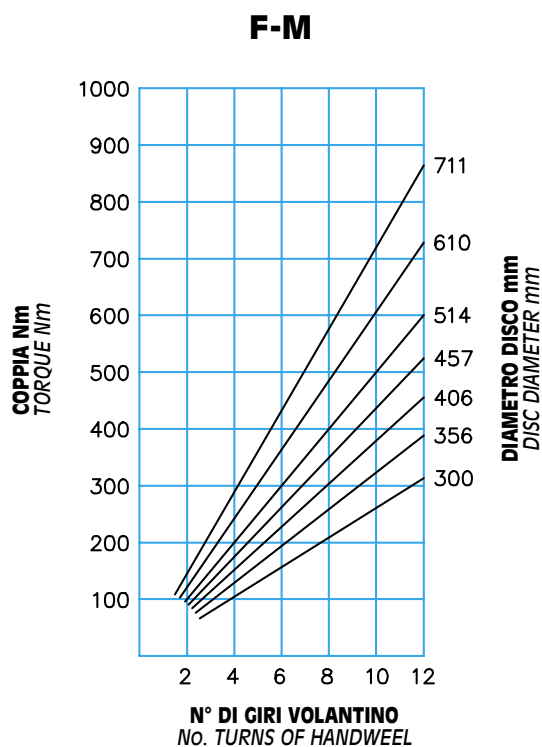
Dissipazione del calore in continuo  
Qc: 3.4 kW

## Technical data

Braking force F:

**F-M** 2670 N 12 turns of handwheelDynamic torque  
=  $F \cdot (\text{disc radius in m} - 0.033) = \text{Nm}$ 

Max total wear: 12 mm

Thickness of new lining: 11 mm

Continuous thermal capacity  
Qc: 3.4 kW

# G-M

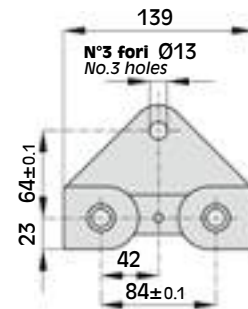

**Vista base di montaggio**  
View on caliper base

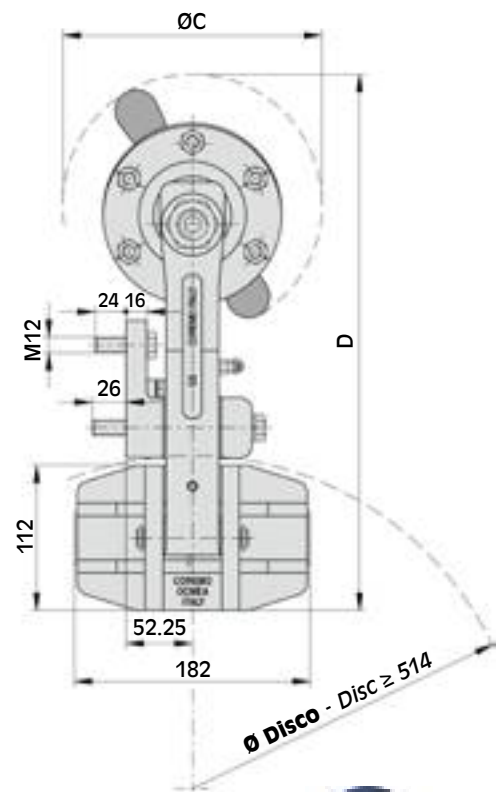
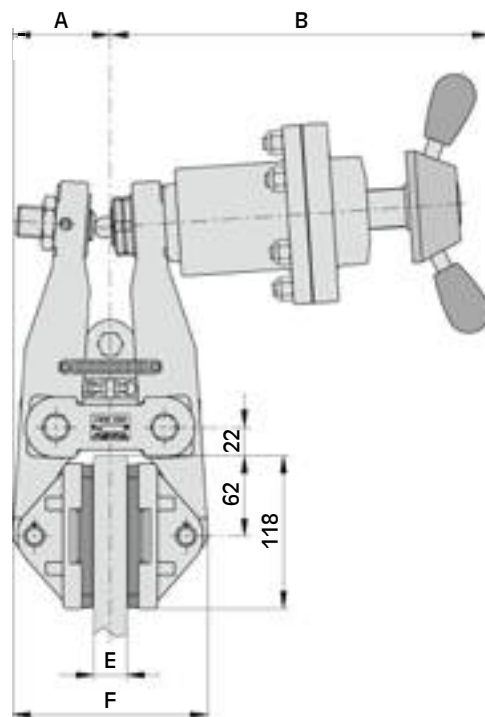

## DIMENSIONI/DIMENSIONS



TIPO SIZE	Cod. Prodotto Product Number	A	B	ØC	D	E	F	Peso Weight kg
G-M	A2936	75.5	293.5	200	413	25.4	151	23.5
	A2940	85	301	200	412	40	165.5	23.5

**Attenzione:** La coppia iniziale può essere dal 30% al 50% in meno rispetto al valore nominale, fino all'assestamento del ferodo sul disco.

**Warning:** The initial torque on new units can be 30% to 50% less than the catalogue value until the friction facing and friction disc are lapped or worn in.

## Dati tecnici

Forza tangenziale F:

**G-M** 21000 N 10 giri del volante

Coppia dinamica  
 $= F \cdot (\text{raggio del disco in m} - 0.062) = \text{Nm}$

Usura max totale: 10 mm

Spessore del ferodo nuovo: 8 mm

Dissipazione del calore in continuo  
 Qc: 14 kW

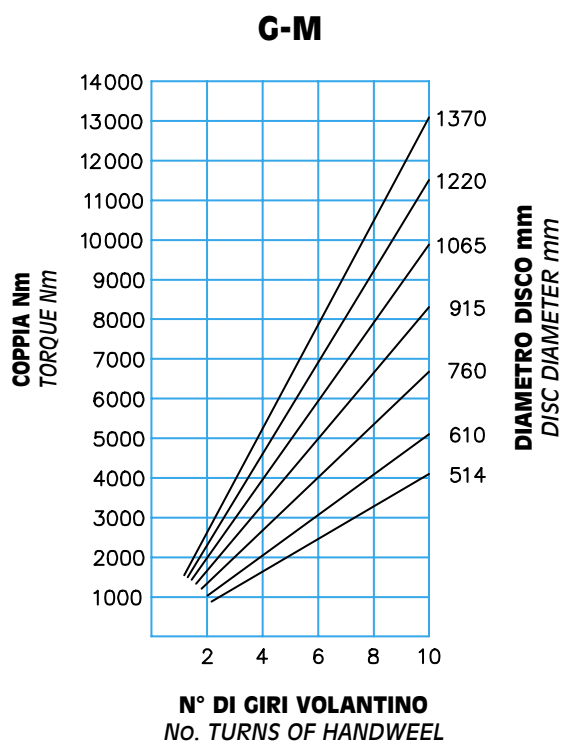

## Technical data

Braking force F:

**G-M** 21000 N 10 turns of handwheel

Dynamic torque  
 $= F \cdot (\text{disc radius in m} - 0.062) = \text{Nm}$

Max total wear: 10 mm

Thickness of new lining: 8 mm

Continuous thermal capacity  
 Qc: 14 kW



# PNEUMATICI Positivi



# PNEUMATIC Air Actuated

**La vasta gamma di freni a pinza a comando pneumatico della COREMO OCMEA rappresenta una sicurezza per le esigenze del progettista di macchine moderne. Svariate possibilità di montaggio abbinata alla sensibilità del comando pneumatico garantiscono un ottimo risultato nella soluzione del problema di frenatura.**

*COREMO OCMEA wide pneumatic caliper brakes range will answer to all needs of new machines. A lot of mounting possibilities combined with pneumatic control sensitivity will ensure a good solution for braking problems.*



# MICRO

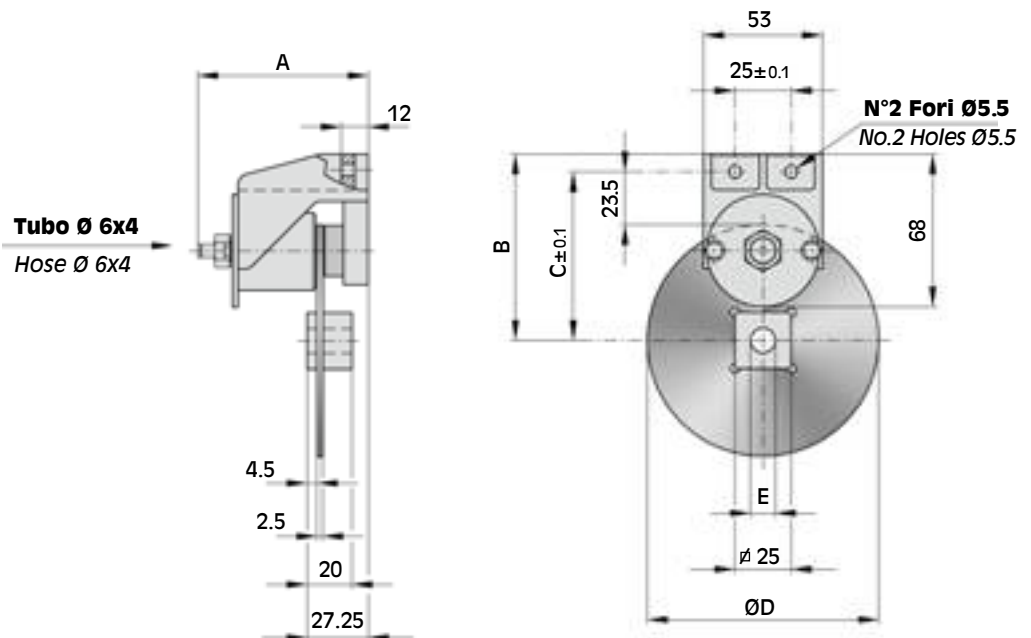

## DIMENSIONI/DIMENSIONS



TIPO SIZE	Cod. Prodotto Product Number	A	B	C	∅D	E min ÷ max	Volume aria Air Volume dm <sup>3</sup>	Peso Weight kg
MICRO	A0822	76	83	75	103	11 ÷ 19	0.38	0.6

**Attenzione:** La coppia iniziale può essere dal 30% al 50% in meno rispetto al valore nominale, fino all'assestamento del ferodo sul disco.

**Warning:** The initial torque on new units can be 30% to 50% less than the catalogue value until the friction facing and friction disc are lapped or worn in.

## Dati tecnici

Forza tangenziale F:

148 N a 6 bar

Coppia dinamica  
 $= F \cdot (\text{raggio del disco in m} - 0.011) = \text{Nm}$

Usura max totale: 12 mm

Spessore del ferodo nuovo: 13 mm

Dissipazione del calore in continuo  
 Qc: 0.2 kW

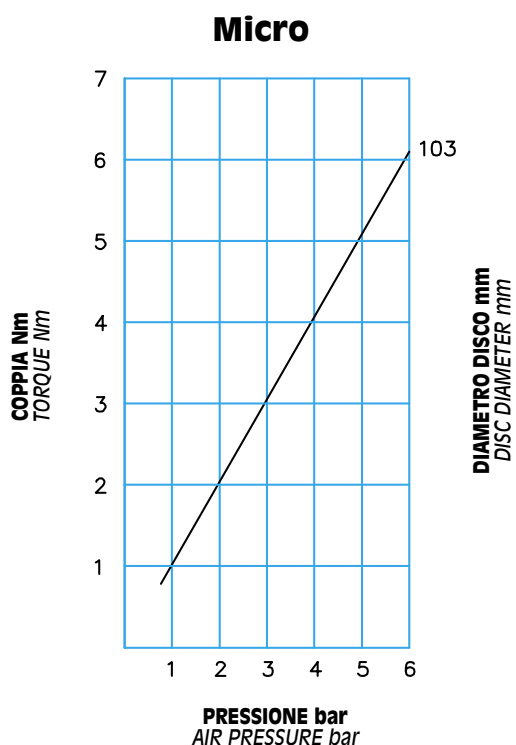

## DIAGRAMMA/CHART

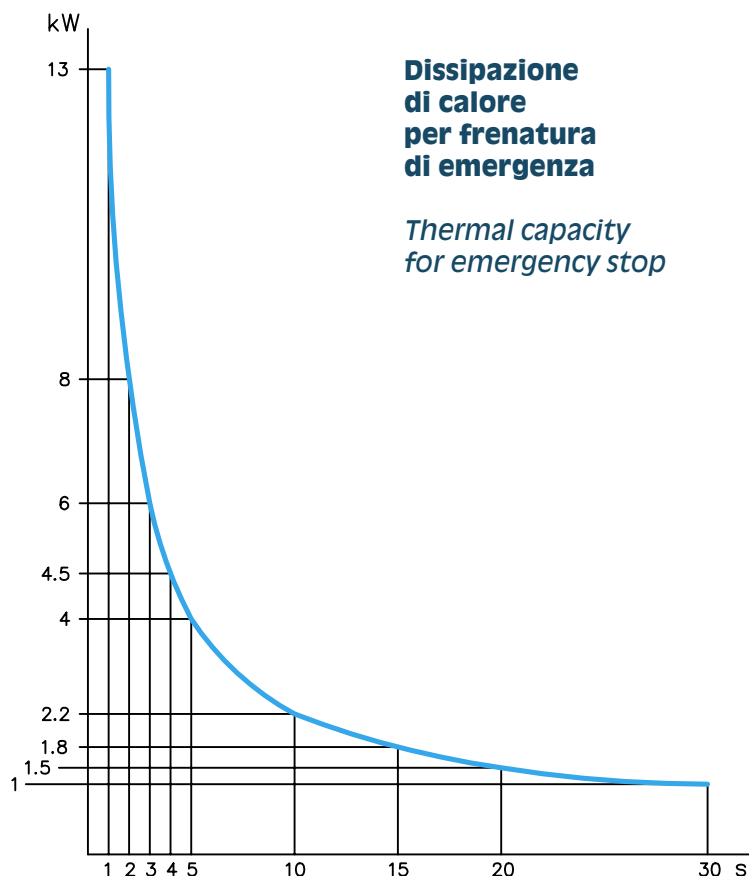

## Technical data

Braking force F:

148 N at 6 bar

Dynamic torque  
 $= F \cdot (\text{disc radius in m} - 0.011) = \text{Nm}$

Max total wear: 12 mm

Thickness of new lining: 13 mm

Continuous thermal capacity  
 Qc: 0.2 kW

# MPA



## MPA

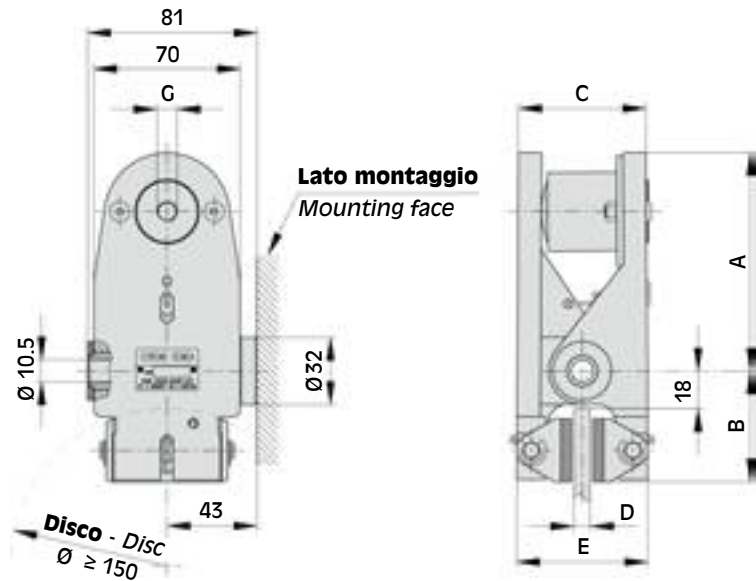

## MPA-05 MPA-1

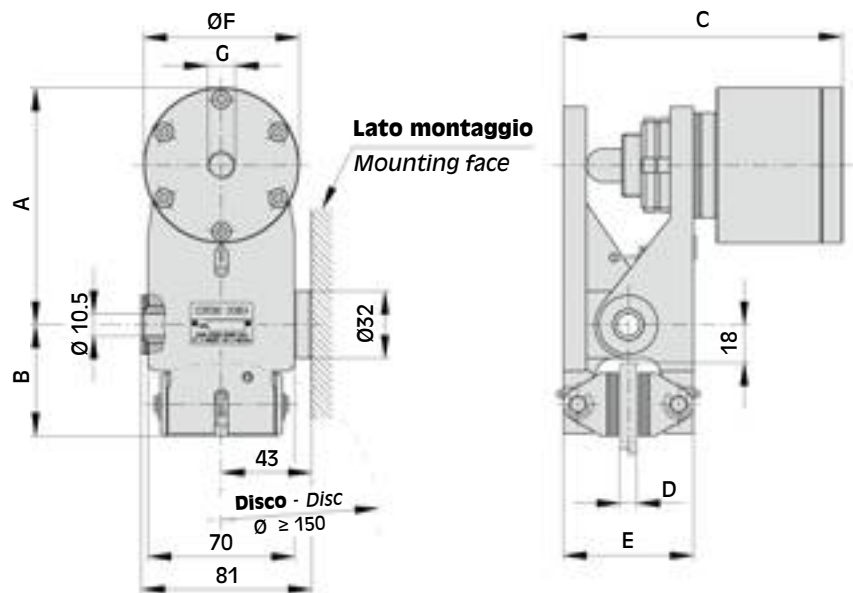

## DIMENSIONI/DIMENSIONS



TIPO SIZE	Cod. Prodotto Product Number	A	B	C		D	E	$\varnothing F$	G	Volume aria Air Volume dm <sup>3</sup>	Peso Weight kg
				min	max						
MPA	A2916	104	53	61	83	8	63	-	1/8"gas	0.0014	1.2
	A2918	106	52	50	71	12.7	68	-	1/8"gas	0.0014	1.2
MPA-05	A2920	113	53	133	154	8	62	74	1/4"gas	0.025	2
	A2922	120	52	143	152	12.7	68	74	1/4"gas	0.025	2
MPA-1	A2924	134	53	143	166	8	62	116	1/4"gas	0.1	2.3
	A2926	140	52	151	162	12.7	69	116	1/4"gas	0.1	2.3

**Attenzione:** La coppia iniziale può essere dal 30% al 50% in meno rispetto al valore nominale, fino all'assestamento del ferodo sul disco.

**Warning:** The initial torque on new units can be 30% to 50% less than the catalogue value until the friction facing and friction disc are lapped or worn in.

## Dati tecnici

Forza tangenziale F:

<b>MPA</b>	556 N a 6 bar
<b>MPA-05</b>	1516 N a 6 bar
<b>MPA-1</b>	3888 N a 6 bar

Coppia dinamica  
 $= F \cdot (\text{raggio del disco in m} - 0.024) = \text{Nm}$

Usura max totale: 6 mm

Spessore del ferodo nuovo: 5 mm

Dissipazione del calore in continuo  
 Qc: 1 kW

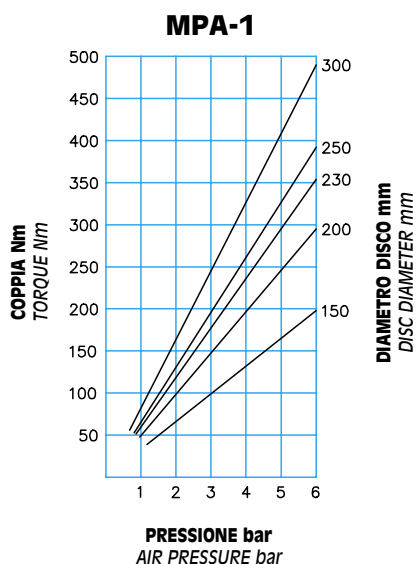
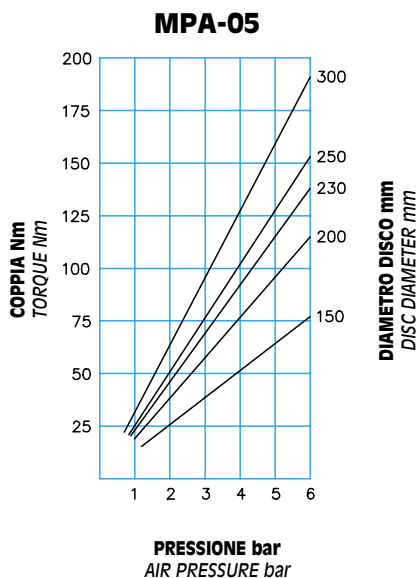
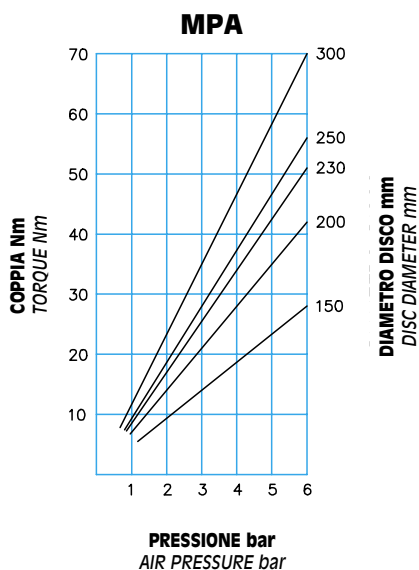

## Technical data

Braking force F:

<b>MPA</b>	556 N at 6 bar
<b>MPA-05</b>	1516 N at 6 bar
<b>MPA-1</b>	3888 N at 6 bar

Dynamic torque  
 $= F \cdot (\text{disc radius in m} - 0.024) = \text{Nm}$

Max total wear: 6 mm

Thickness of new lining: 5 mm

Continuous thermal capacity  
 Qc: 1 kW

## DIAGRAMMA/CHART

**Dissipazione di calore per frenatura di emergenza**

Thermal capacity for emergency stop

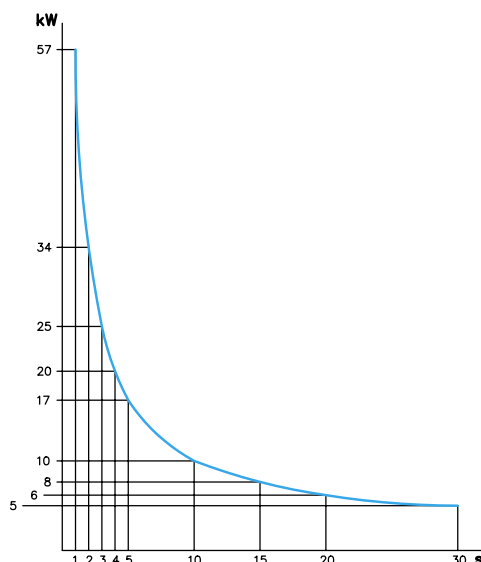

# A



**Disponibile anche per disco spessore 25,4 mm.**  
*Available also for disc thickness 25,4 mm.*

**Versione pattino doppio**  
*Double pad version*

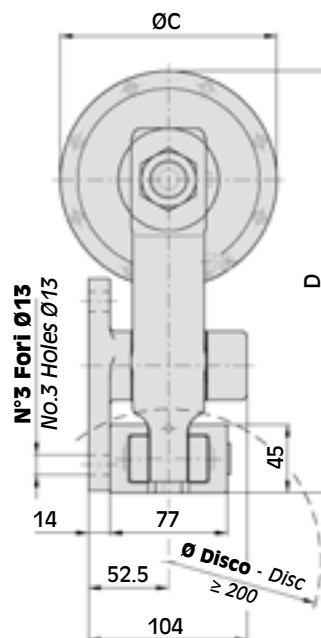
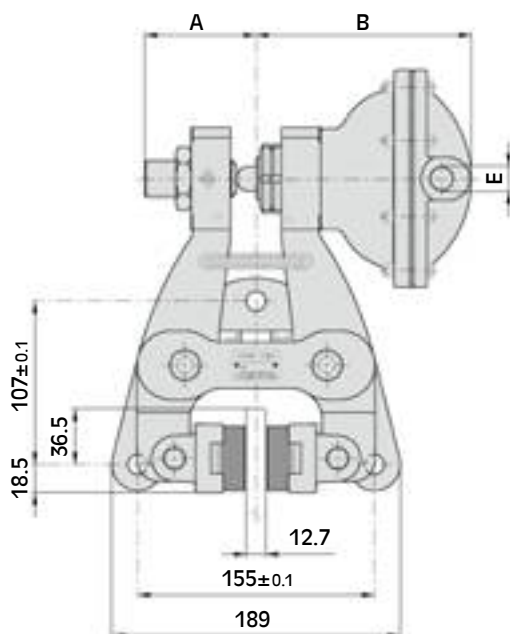
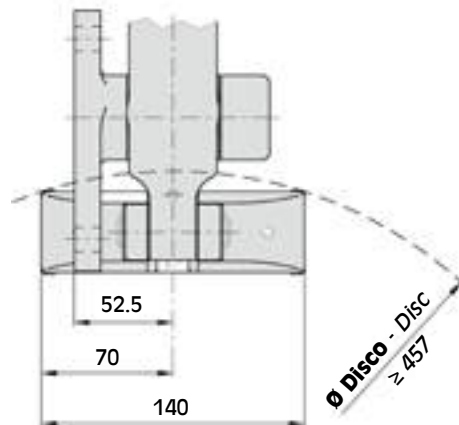

## DIMENSIONI/DIMENSIONS



TIPO SIZE	Cod. Prodotto Product Number		A	B	ØC	D	E	Volume aria Air Volume dm <sup>3</sup>	Peso Weight kg
	S.P.	S.U.							
A05	A3242	A3244	75.5	106.5	74	242.5	1/4"gas	0.025	10.8
A1	A3250	A3252	73	119	116	263.5	1/4"gas	0.1	11.1
A2	A3258	A3260	73	141	142	276.5	3/8"gas	0.2	11.9
A3	A3266	A3268	73	159.5	184	297.5	3/8"gas	0.4	13.1
<p><b>S.P. = Produzione Standard / Standard Production</b>  <b>S.U. = Con segnalatore di usura / With Wear Indicator</b></p>									

**Attenzione:** La coppia iniziale può essere dal 30% al 50% in meno rispetto al valore nominale, fino all'assestamento del ferodo sul disco.

**Warning:** The initial torque on new units can be 30% to 50% less than the catalogue value until the friction facing and friction disc are lapped or worn in.

## Dati tecnici

Forza tangenziale F:

<b>A05</b>	1730 N a 6 bar
<b>A1</b>	4100 N a 6 bar
<b>A2</b>	8000 N a 6 bar
<b>A3</b>	13700 N a 6 bar

Coppia dinamica  
=  $F \cdot (\text{raggio del disco in m} - 0.03) = \text{Nm}$

Usura max totale: 16 mm

Spessore del ferodo nuovo: 16 mm

Dissipazione del calore in continuo  
Qc: 1.7 kW

Dissipazione del calore in continuo  
con pattino doppio  
Qc: 2.7 kW

## Technical data

Braking force F:

<b>A05</b>	1730 N at 6 bar
<b>A1</b>	4100 N at 6 bar
<b>A2</b>	8000 N at 6 bar
<b>A3</b>	13700 N at 6 bar

Dynamic torque  
=  $F \cdot (\text{disc radius in m} - 0.03) = \text{Nm}$

Max total wear: 16 mm

Thickness of new lining: 16 mm

Continuous thermal capacity  
Qc: 1.7 kW

Continuous thermal capacity  
for double pad version  
Qc: 2.7 kW

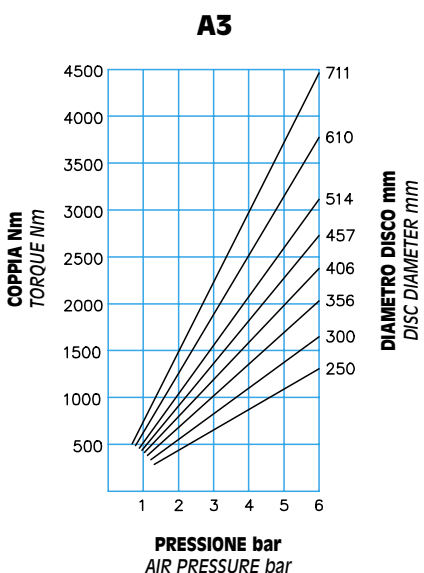
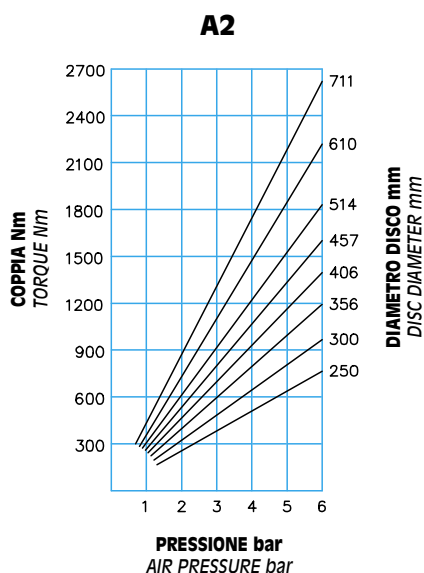
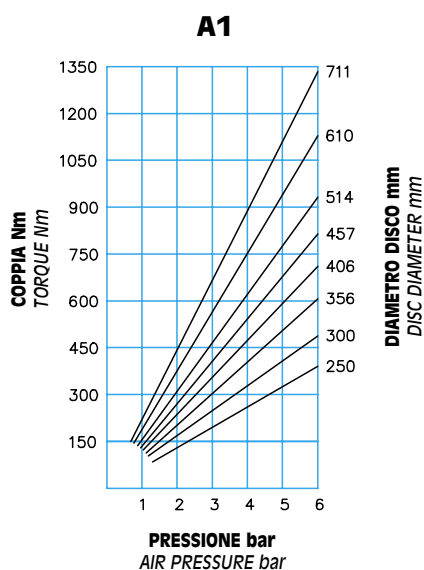
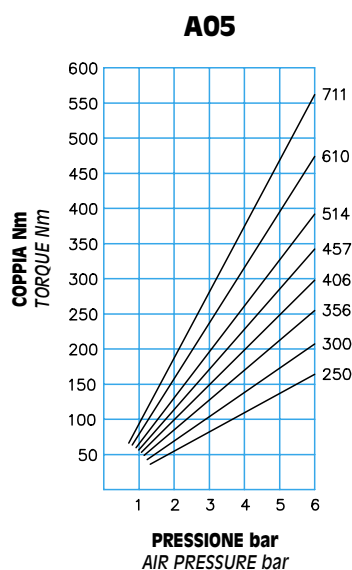

## DIAGRAMMA/CHART

Dissipazione di calore per frenatura di emergenza

Thermal capacity for emergency stop

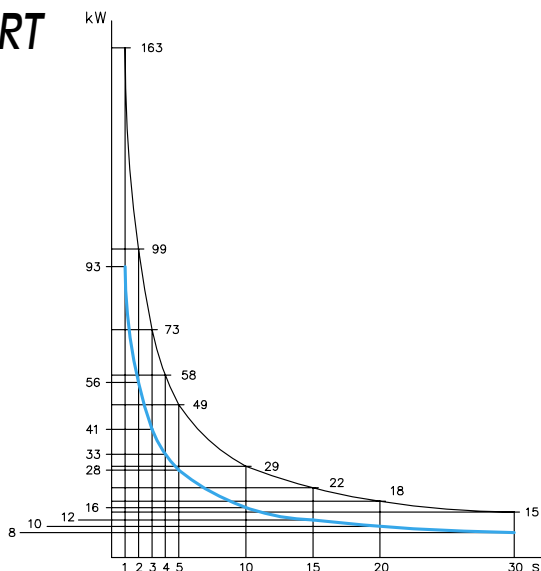

# B

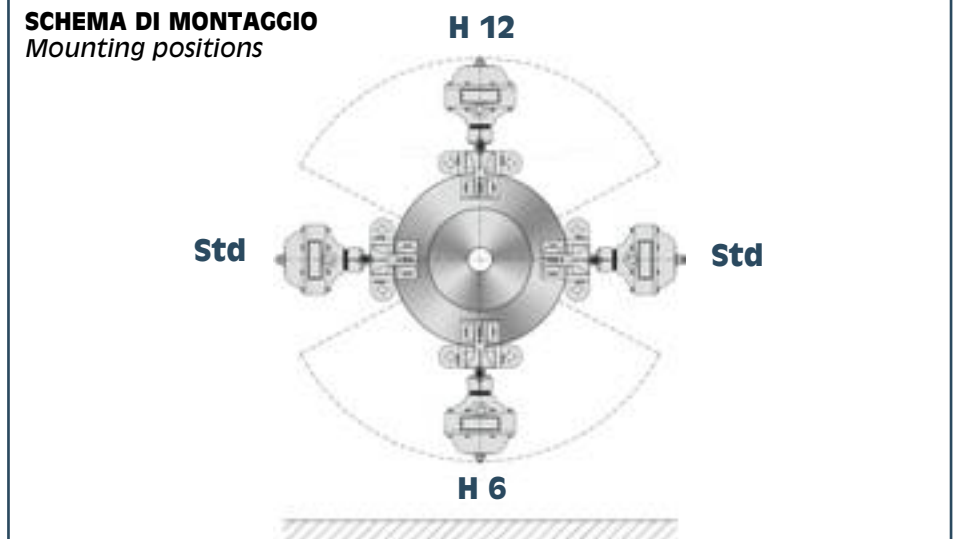

**Versione pattino doppio**  
Double pad version

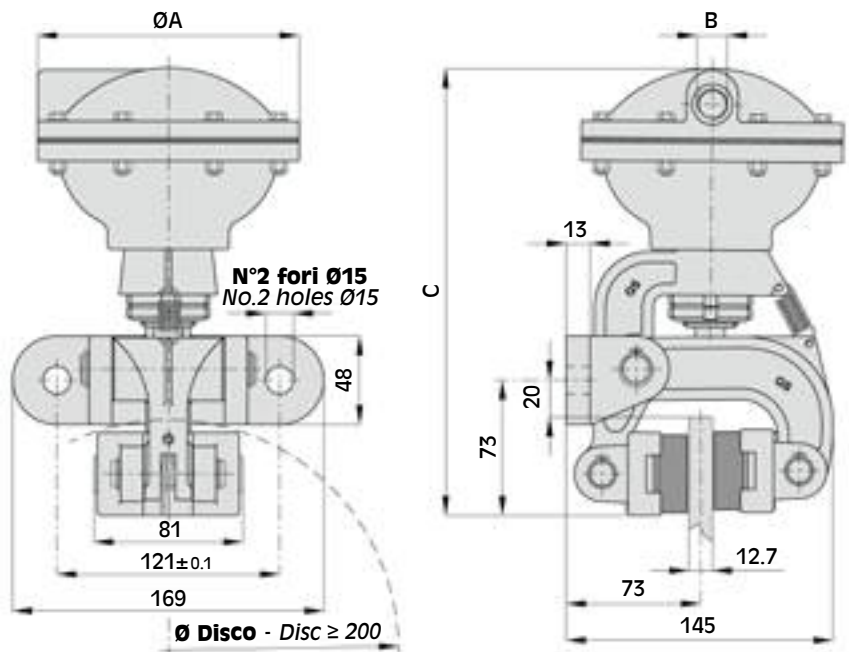
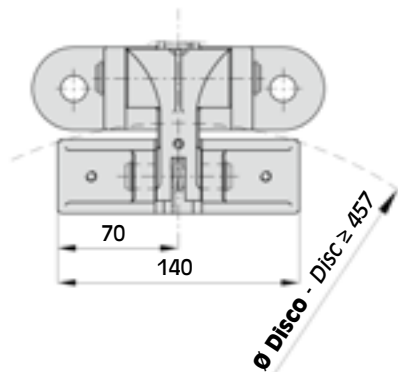

## DIMENSIONI/DIMENSIONS



TIPO SIZE	Cod. Prodotto Product Number						ØA	B	C	Volume aria Air Volume dm <sup>3</sup>	Peso Weight kg
	Std	Std S.U.	H6	H6 S.U.	H12	H12 S.U.					
<b>B05</b>	A2014	A2015	A2348	A2349	A2354	A2355	74	1/4"gas	210.5	0.025	5.3
<b>B1</b>	A2020	A2021	A2038	A2039	A2056	A2057	116	1/4"gas	221	0.1	5.5
<b>B2</b>	A2026	A2027	A2044	A2045	A2062	A2063	142	3/8"gas	243	0.2	6.3
<p><b>S.P. = Produzione Standard / Standard Production</b>  <b>S.U. = Con segnalatore di usura / With Wear Indicator</b></p>											

**Attenzione:** La coppia iniziale può essere dal 30% al 50% in meno rispetto al valore nominale, fino all'assestamento del ferodo sul disco.

**Warning:** The initial torque on new units can be 30% to 50% less than the catalogue value until the friction facing and friction disc are lapped or worn in.

## Dati tecnici

Forza tangenziale F:

<b>B05</b>	670 N a 6 bar
<b>B1</b>	1800 N a 6 bar
<b>B2</b>	3550 N a 6 bar

Coppia dinamica  
=  $F \cdot (\text{raggio del disco in m} - 0.032) = \text{Nm}$

Usura max totale: 14 mm

Spessore del ferodo nuovo: 16 mm

Dissipazione del calore in continuo  
Qc: 1.7 kW

Dissipazione del calore in continuo  
con pattino doppio  
Qc: 2.7 kW

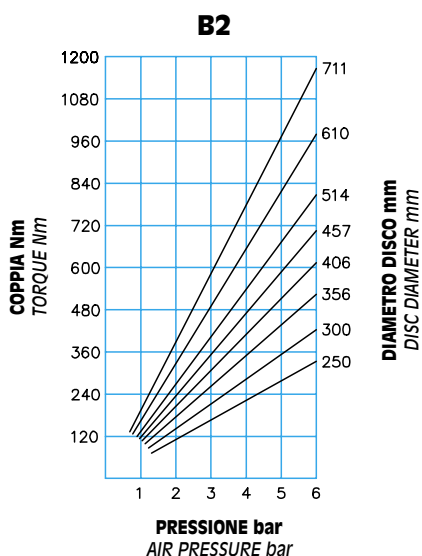
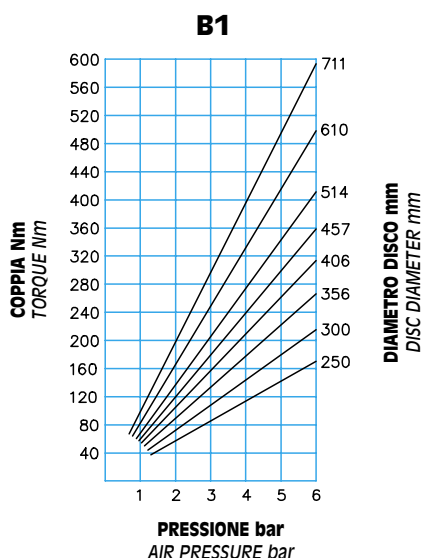
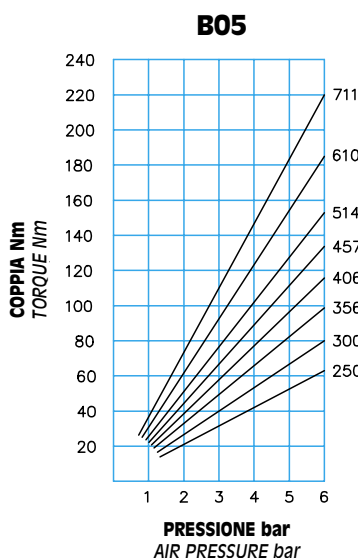

## Technical data

Braking force F:

<b>B05</b>	670 N at 6 bar
<b>B1</b>	1800 N at 6 bar
<b>B2</b>	3550 N at 6 bar

Dynamic torque  
=  $F \cdot (\text{disc radius in m} - 0.032) = \text{Nm}$

Max total wear: 14 mm

Thickness of new lining: 16 mm

Continuous thermal capacity  
Qc: 1.7 kW

Continuous thermal capacity  
for double pad version  
Qc: 2.7 kW

## DIAGRAMMA/CHART

**Dissipazione di calore per frenatura di emergenza**

*Thermal capacity for emergency stop*

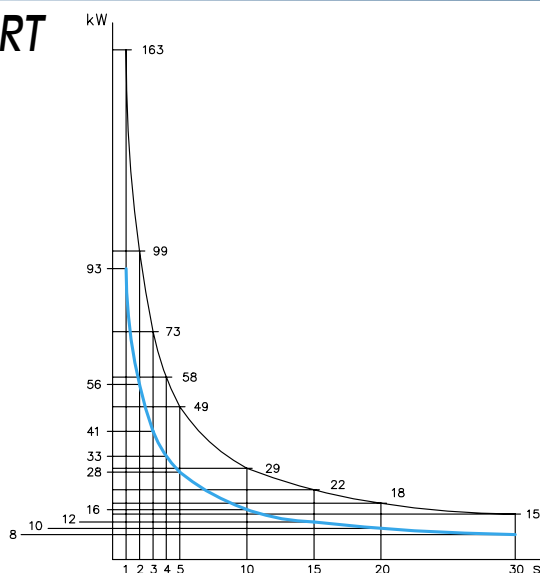

Pattino doppio Double pad  
Pattino standard Standard pad

# C

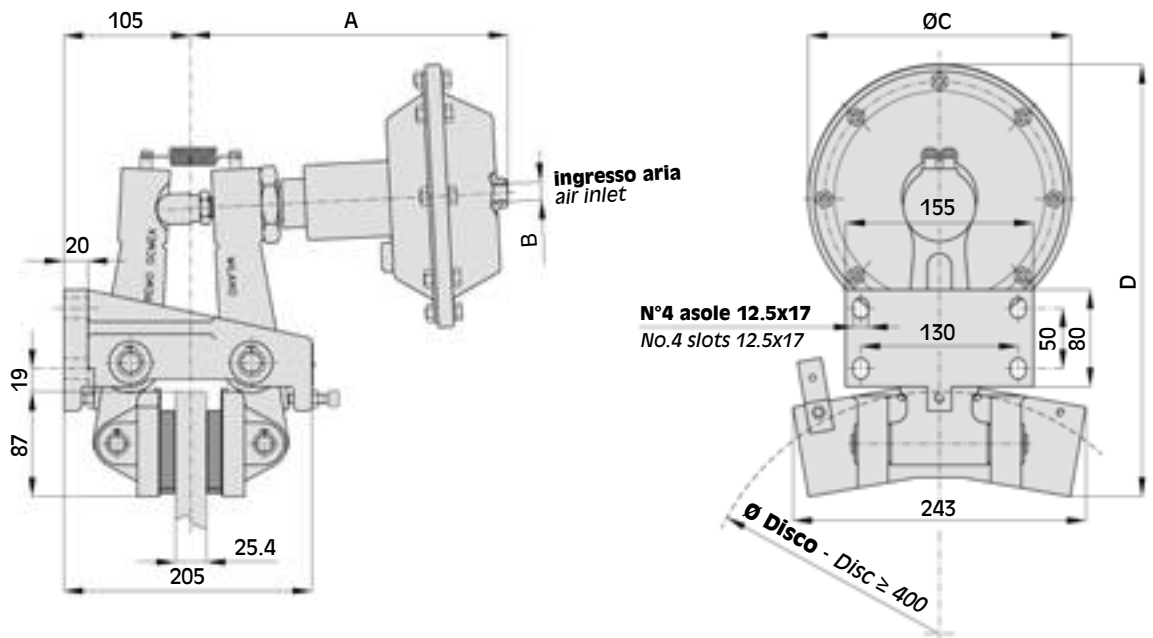

## DIMENSIONI/DIMENSIONS



TIPO SIZE	Cod. Prodotto Product Number	A	B	ØC	D	Volume aria Air Volume dm <sup>3</sup>	Peso Weight kg
C300	A2178	241	1/4" gas	154	325	0.33	20
C600	A2181	264	1/4" gas	217	358	0.83	23
C1200	A2184	314	1/2" gas	270	386	1.63	26

**Attenzione:** La coppia iniziale può essere dal 30% al 50% in meno rispetto al valore nominale, fino all'assestamento del ferodo sul disco.

**Warning:** The initial torque on new units can be 30% to 50% less than the catalogue value until the friction facing and friction disc are lapped or worn in.

## Dati tecnici

Forza tangenziale F:

<b>C300</b>	5400 N a 6 bar
<b>C600</b>	13200 N a 6 bar
<b>C1200</b>	22500 N a 6 bar

Coppia dinamica  
 $= F \cdot (\text{raggio del disco in m} - 0.044) = \text{Nm}$

Usura max totale: 14 mm

Spessore del ferodo nuovo: 11 mm

Dissipazione del calore in continuo  
 Qc: 5.5 kW

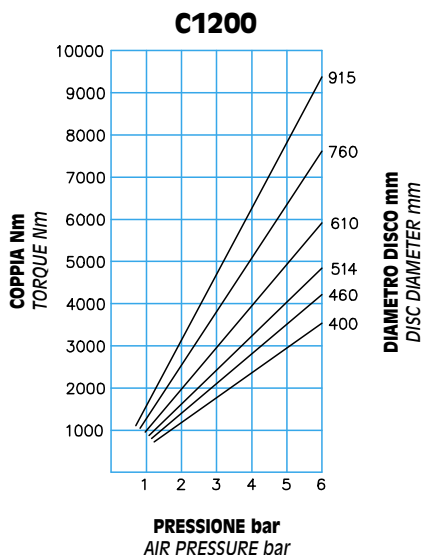
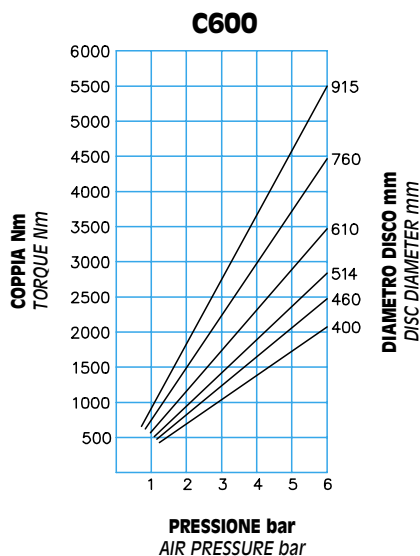
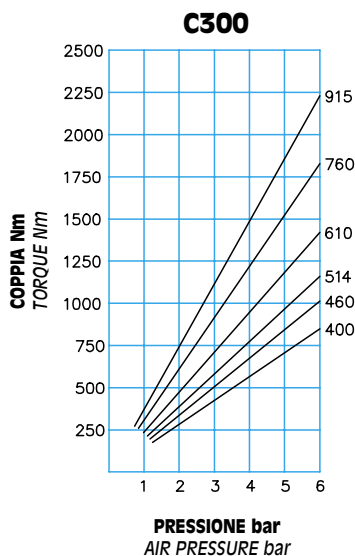

## Technical data

Braking force F:

<b>C300</b>	5400 N at 6 bar
<b>C600</b>	13200 N at 6 bar
<b>C1200</b>	22500 N at 6 bar

Dynamic torque  
 $= F \cdot (\text{disc radius in m} - 0.044) = \text{Nm}$

Max total wear: 14 mm

Thickness of new lining: 11 mm

Continuous thermal capacity  
 Qc: 5.5 kW

## DIAGRAMMA/CHART

**Dissipazione di calore per frenatura di emergenza**

*Thermal capacity for emergency stop*

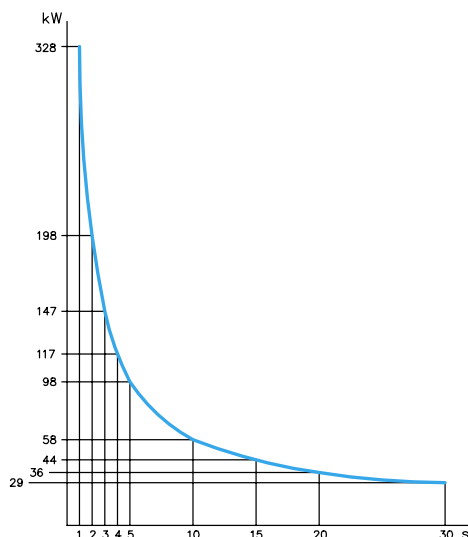

# D

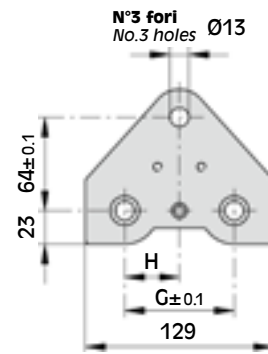

**Vista base di montaggio**  
View on caliper base

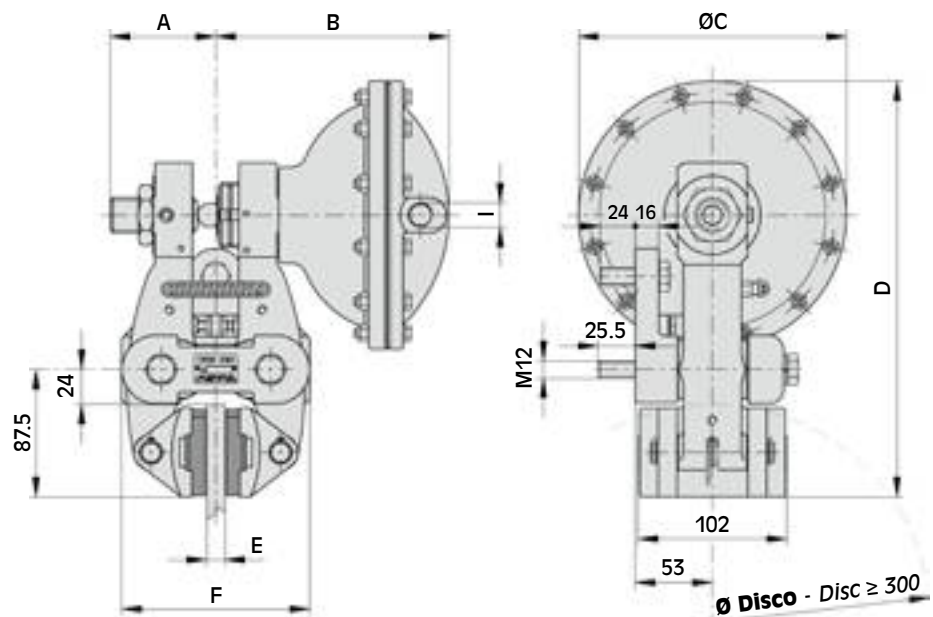

## DIMENSIONI/DIMENSIONS



TIPO SIZE	Cod. Prodotto Product Number	A	B	ØC	D	E	F	G	H	I	Volume aria Air Volume dm <sup>3</sup>	Peso Weight kg
D05	A2398	75	107	74	230.5	12.7	129	75	37.5	1/4"gas	0.025	9.5
	A2406	74.5	109	74	232.5	25.4	132	84	42	1/4"gas	0.025	9.5
	A2414	86	116	74	230.5	30	140	75	37.5	1/4"gas	0.025	9.5
	A2422	81.5	120.5	74	230.5	40	149	84	42	1/4"gas	0.025	9.5
D1	A2430	72.5	119.5	116	251.5	12.7	129	75	37.5	1/4"gas	0.1	9.8
	A2438	72	120	116	253	25.4	132	84	42	1/4"gas	0.1	9.8
	A2446	83.5	128.5	116	251.5	30	140	75	37.5	1/4"gas	0.1	9.8
	A2454	79	133	116	251.5	40	149	84	42	1/4"gas	0.1	9.8
D2	A2462	72.5	141.5	142	264.5	12.7	129	75	37.5	3/8"gas	0.2	10.6
	A2470	72	142	142	267.5	25.4	132	84	42	3/8"gas	0.2	10.6
	A2478	83.5	150.5	142	264.5	30	140	75	37.5	3/8"gas	0.2	10.6
	A2486	79	155	142	264.5	40	149	84	42	3/8"gas	0.2	10.6
D3	A2494	72.5	160	184	285.5	12.7	129	75	37.5	3/8"gas	0.4	11.8
	A2502	72	161	184	289	25.4	132	84	42	3/8"gas	0.4	11.8
	A2510	83.5	169	184	285.5	30	140	75	37.5	3/8"gas	0.4	11.8
	A2518	79	174	184	285.5	40	149	84	42	3/8"gas	0.4	11.8

**Attenzione:** La coppia iniziale può essere dal 30% al 50% in meno rispetto al valore nominale, fino all'assestamento del ferodo sul disco.

**Warning:** The initial torque on new units can be 30% to 50% less than the catalogue value until the friction facing and friction disc are lapped or worn in.

## Dati tecnici

Forza tangenziale F:

<b>D05</b>	1600 N a 6 bar
<b>D1</b>	3800 N a 6 bar
<b>D2</b>	7500 N a 6 bar
<b>D3</b>	12700 N a 6 bar

Coppia dinamica  
 $= F \cdot (\text{raggio del disco in m} - 0.033) = \text{Nm}$

Usura max totale: 12 mm

Spessore del ferodo nuovo: 11 mm

Dissipazione del calore in continuo  
 QC: 3.4 kW

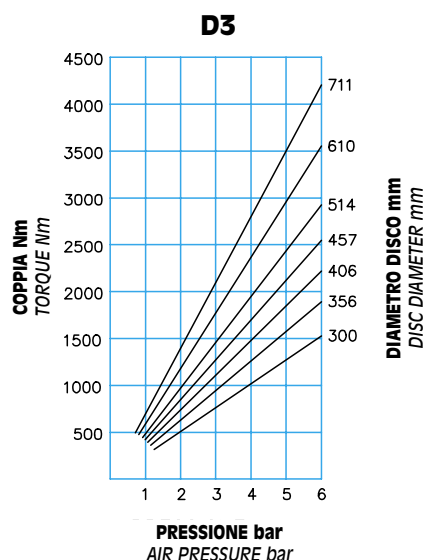
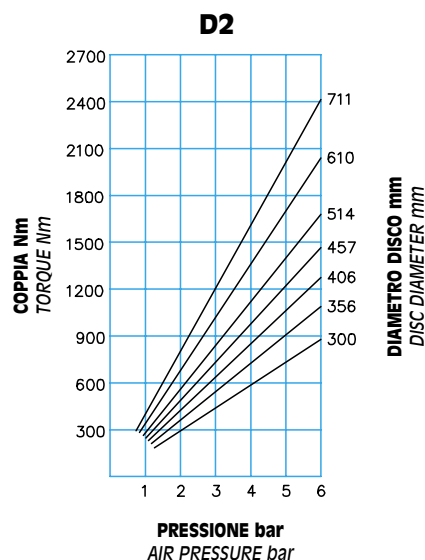
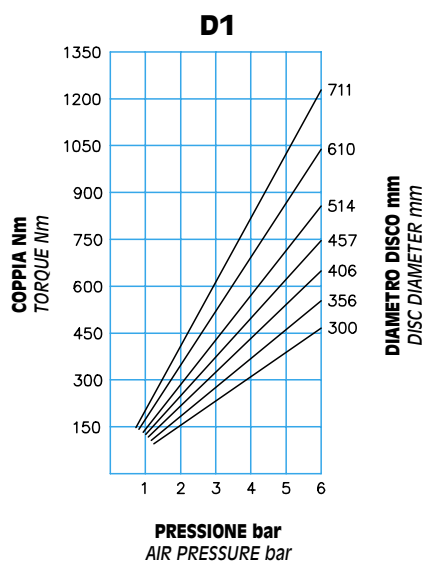
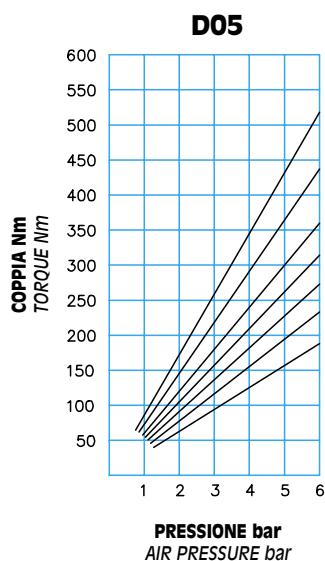

## Technical data

Braking force F:

<b>D05</b>	1600 N at 6 bar
<b>D1</b>	3800 N at 6 bar
<b>D2</b>	7500 N at 6 bar
<b>D3</b>	12700 N at 6 bar

Dynamic torque  
 $= F \cdot (\text{disc radius in m} - 0.033) = \text{Nm}$

Max total wear: 12 mm

Thickness of new lining: 11 mm

Continuous thermal capacity  
 QC: 3.4 kW

## DIAGRAMMA/CHART

**Dissipazione di calore per frenatura di emergenza**

Thermal capacity for emergency stop

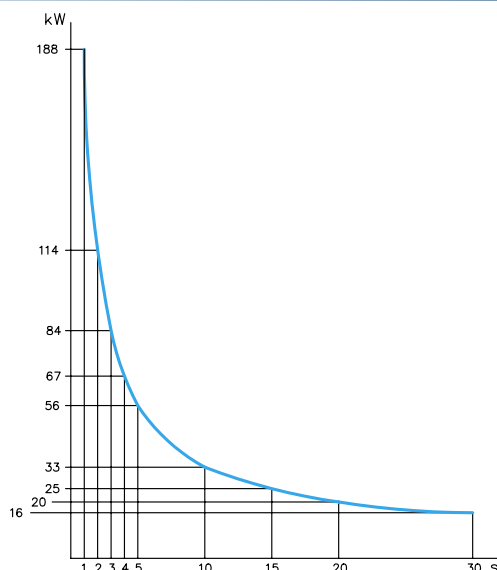

# E

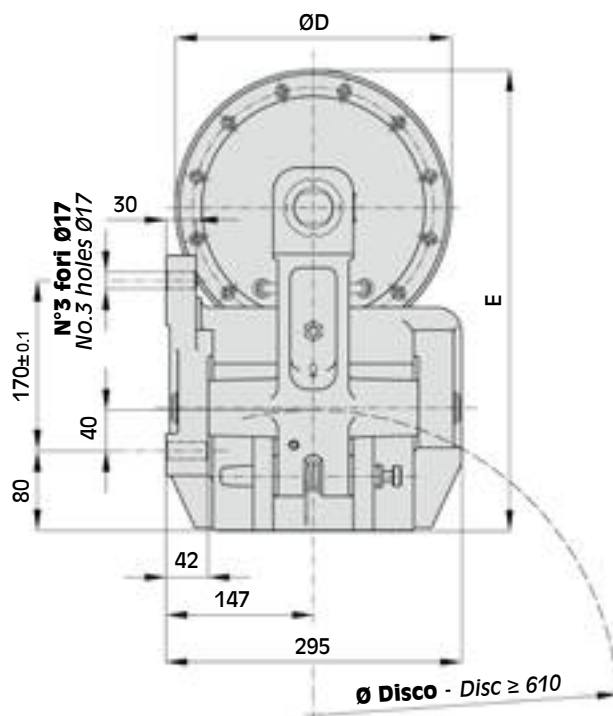
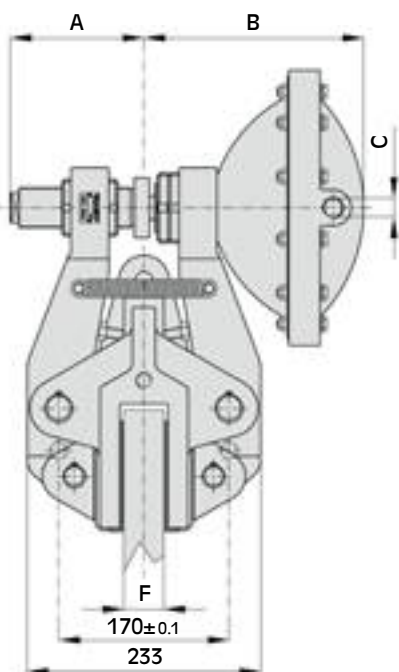

## DIMENSIONI/DIMENSIONS



TIPO SIZE	Cod. Prodotto Product Number	A	B	C	ØD	E	F	Volume aria Air Volume dm <sup>3</sup>	Peso Weight kg
E3	A1955	126	180	3/8"gas	184	415	25.4	0.4	57
	A1949	126	180	3/8"gas	184	415	40	0.4	57
E4	A1940	135.5	219.5	1/2"gas	275	460	25.4	1.2	63
	A1934	135.5	219.5	1/2"gas	275	460	40	1.2	63

**Attenzione:** La coppia iniziale può essere dal 30% al 50% in meno rispetto al valore nominale, fino all'assestamento del ferodo sul disco.

**Warning:** The initial torque on new units can be 30% to 50% less than the catalogue value until the friction facing and friction disc are lapped or worn in.

## Dati tecnici

Forza tangenziale F:

**E3** 20180 N a 6 bar  
**E4** 36600 N a 6 bar

Coppia dinamica  
 $= F \cdot (\text{raggio del disco in m} - 0.065) = \text{Nm}$

Usura max totale: 12 mm

Spessore del ferodo nuovo: 13 mm

Dissipazione del calore in continuo  
 QC: 20 kW

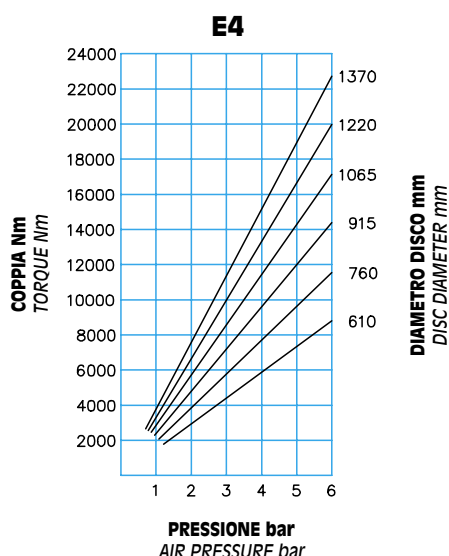
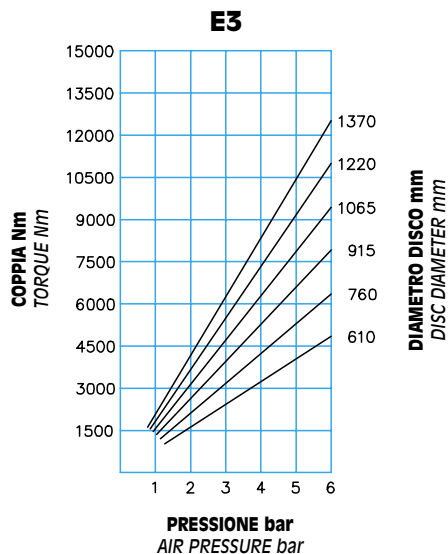

## DIAGRAMMA/CHART

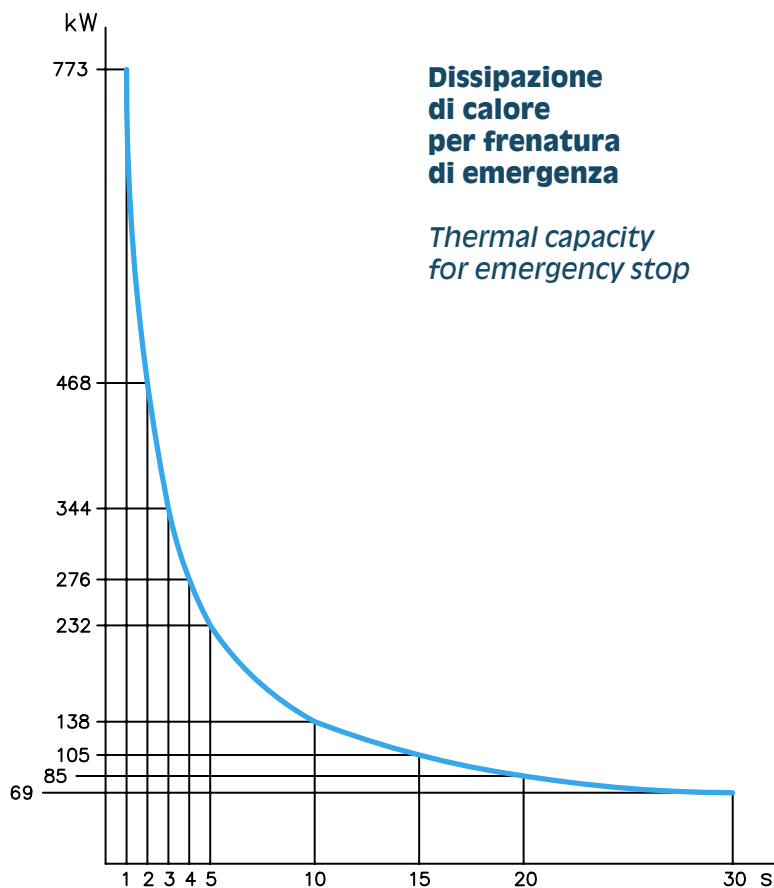

## Technical data

Braking force F:

**E3** 20180 N at 6 bar  
**E4** 36600 N at 6 bar

Dynamic torque  
 $= F \cdot (\text{disc radius in m} - 0.065) = \text{Nm}$

Max total wear: 12 mm

Thickness of new lining: 13 mm

Continuous thermal capacity  
 QC: 20 kW

# EL

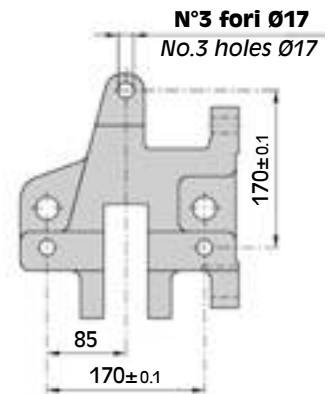

**Vista montaggio frontale**  
Frontal mounting view

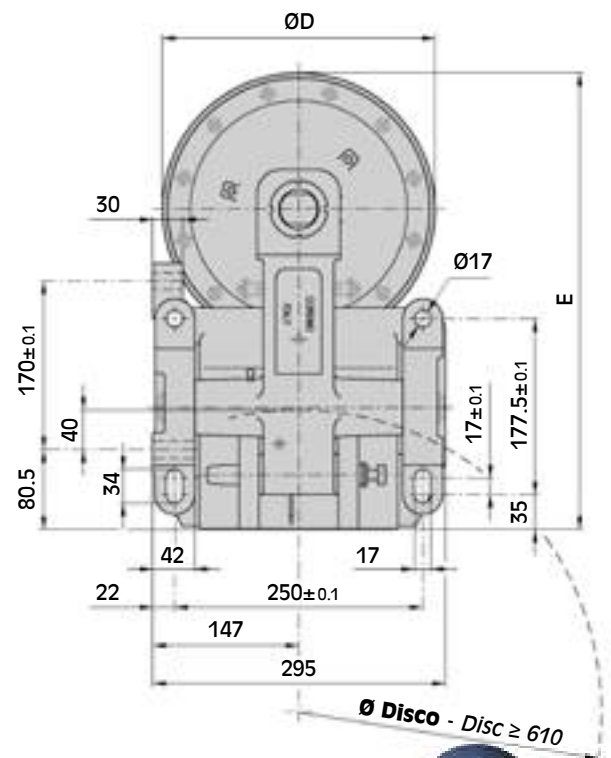
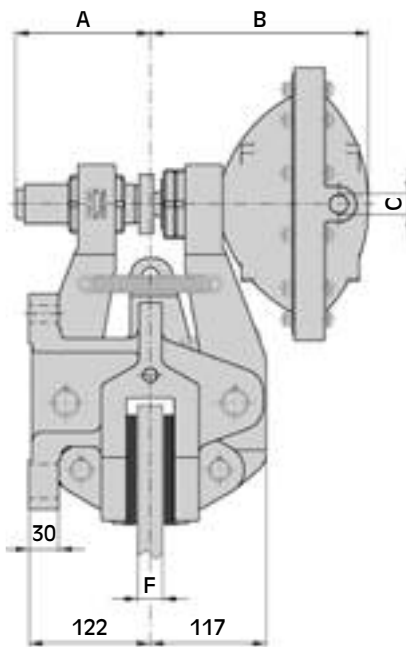

## DIMENSIONI/DIMENSIONS



TIPO SIZE	Cod. Prodotto Product Number	A	B	C	ØD	E	F	Volume aria Air Volume dm <sup>3</sup>	Peso Weight kg
EL3	A3575	126	180	3/8"gas	184	415	25.4	0.4	60
	A3578	126	180	3/8"gas	184	415	40	0.4	60
EL4	A3581	135.5	219.5	1/2"gas	275	460	25.4	1.2	66
	A3584	135.5	219.5	1/2"gas	275	460	40	1.2	66

**Attenzione:** La coppia iniziale può essere dal 30% al 50% in meno rispetto al valore nominale, fino all'assestamento del ferodo sul disco.

**Warning:** The initial torque on new units can be 30% to 50% less than the catalogue value until the friction facing and friction disc are lapped or worn in.

## Dati tecnici

Forza tangenziale F:

**EL3** 20180 N a 6 bar  
**EL4** 36600 N a 6 bar

Coppia dinamica  
 $= F \cdot (\text{raggio del disco in m} - 0.065) = \text{Nm}$

Usura max totale: 12 mm

Spessore del ferodo nuovo: 13 mm

Dissipazione del calore in continuo  
 Qc: 20 kW

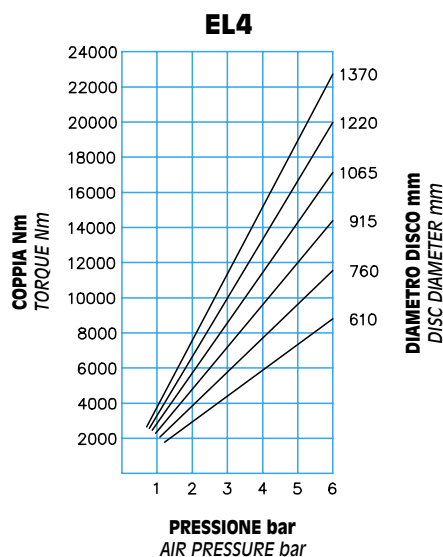
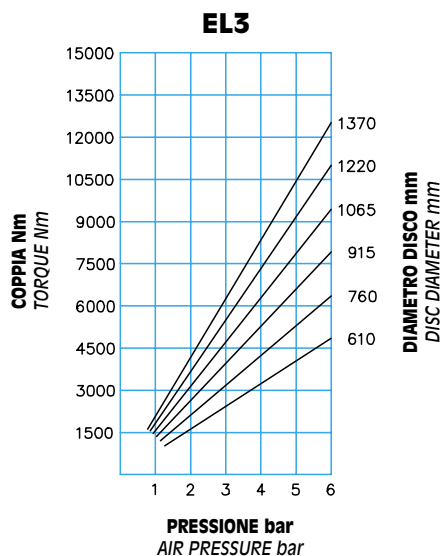

## DIAGRAMMA/CHART

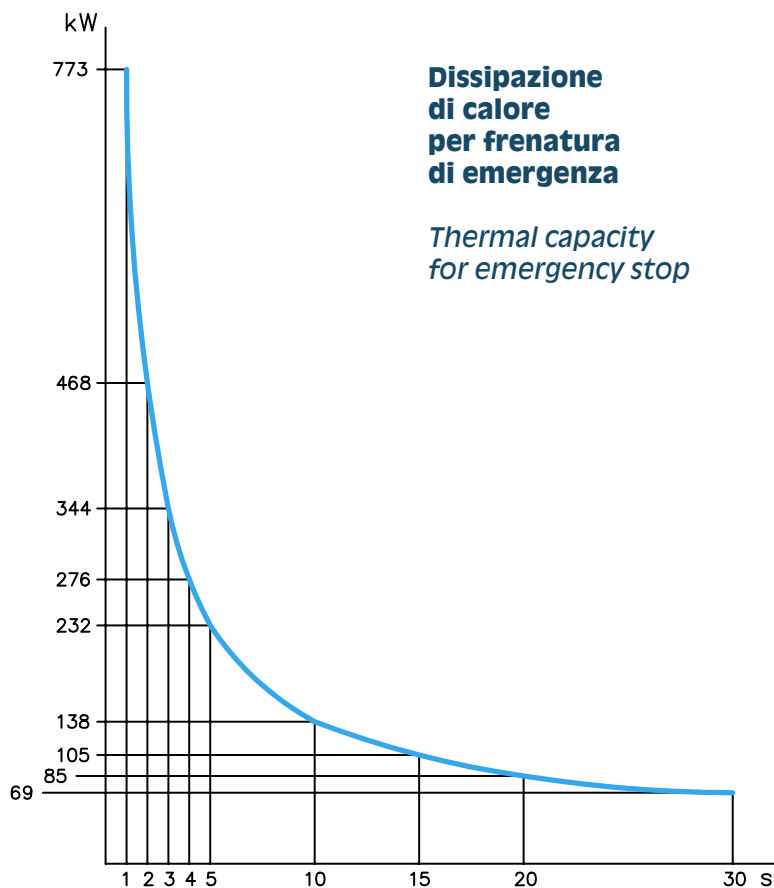

## Technical data

Braking force F:

**EL3** 20180 N at 6 bar  
**EL4** 36600 N at 6 bar

Dynamic torque  
 $= F \cdot (\text{disc radius in m} - 0.065) = \text{Nm}$

Max total wear: 12 mm

Thickness of new lining: 13 mm

Continuous thermal capacity  
 Qc: 20 kW

F

Disponibile anche per disco spessore 25,4 - 30 - 40 mm.  
Available also for disc thickness 25,4 - 30 - 40 mm.

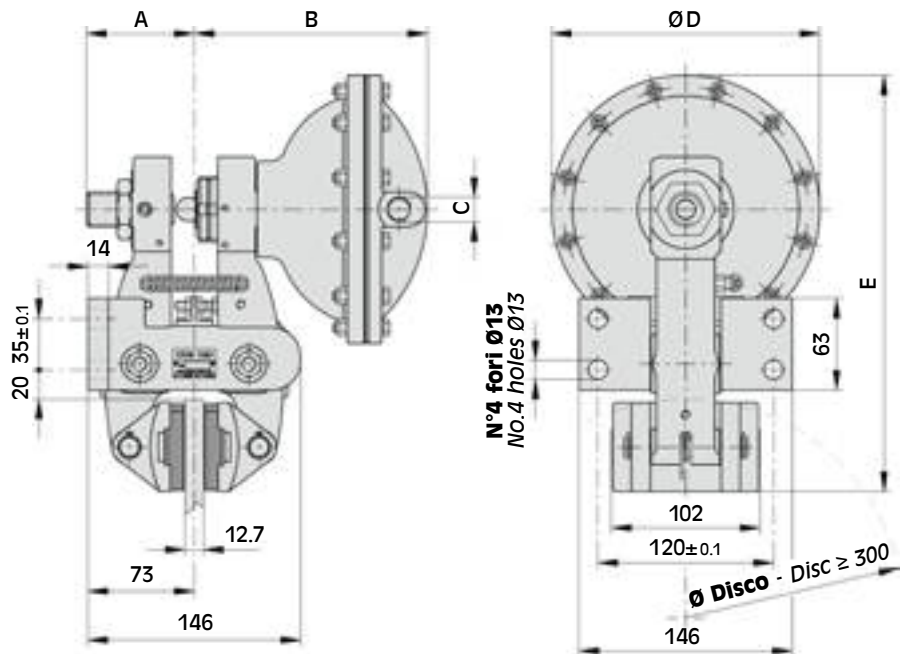

DIMENSIONI/DIMENSIONS



TIPO SIZE	Cod. Prodotto Product Number	A	B	C	ØD	E	Volume aria Air Volume dm <sup>3</sup>	Peso Weight kg
F05	A2758	75	107	1/4" gas	74	230.5	0.025	9.2
F1	A2766	72.5	119.5	1/4" gas	116	251.5	0.1	9.5
F2	A2774	72.5	141.5	3/8" gas	142	264.5	0.2	10.3
F3	A2782	72.5	160	3/8" gas	184	285.5	0.4	11.5

**Attenzione:** La coppia iniziale può essere dal 30% al 50% in meno rispetto al valore nominale, fino all'assestamento del ferodo sul disco.

**Warning:** The initial torque on new units can be 30% to 50% less than the catalogue value until the friction facing and friction disc are lapped or worn in.

## Dati tecnici

Forza tangenziale F:

<b>F05</b>	1600 N a 6 bar
<b>F1</b>	3800 N a 6 bar
<b>F2</b>	7500 N a 6 bar
<b>F3</b>	12700 N a 6 bar

Coppia dinamica  
 $= F \cdot (\text{raggio del disco in m} - 0.033) = \text{Nm}$

Usura max totale: 12 mm

Spessore del ferodo nuovo: 11 mm

Dissipazione del calore in continuo  
 QC: 3.4 kW

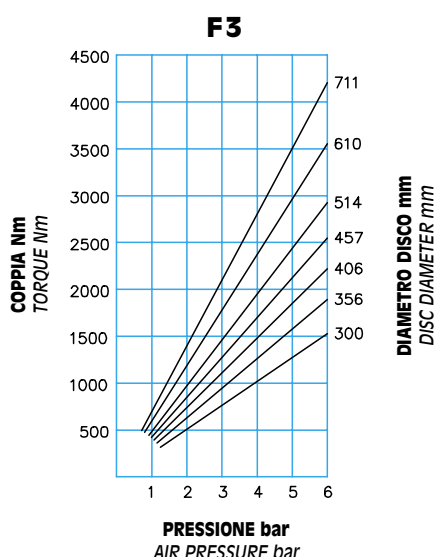
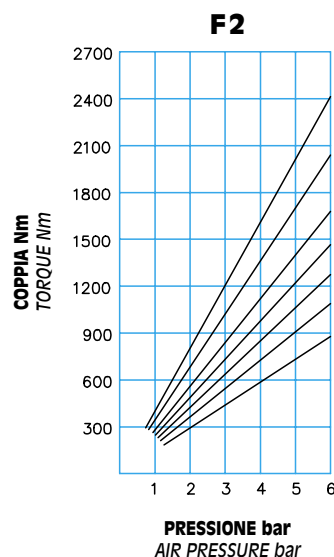
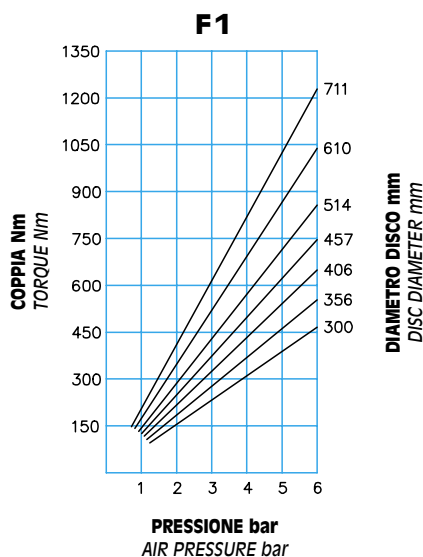
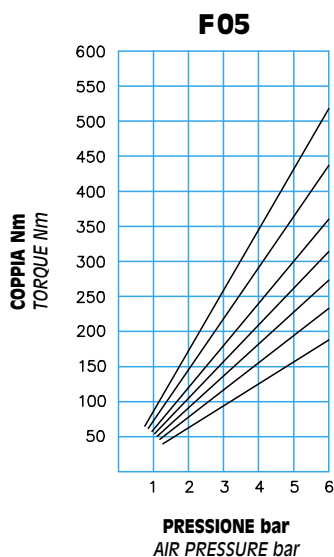

## Technical data

Braking force F:

<b>F05</b>	1600 N at 6 bar
<b>F1</b>	3800 N at 6 bar
<b>F2</b>	7500 N at 6 bar
<b>F3</b>	12700 N at 6 bar

Dynamic torque  
 $= F \cdot (\text{disc radius in m} - 0.033) = \text{Nm}$

Max total wear: 12 mm

Thickness of new lining: 11 mm

Continuous thermal capacity  
 QC: 3.4 kW

## DIAGRAMMA/CHART

**Dissipazione di calore per frenatura di emergenza**

Thermal capacity for emergency stop

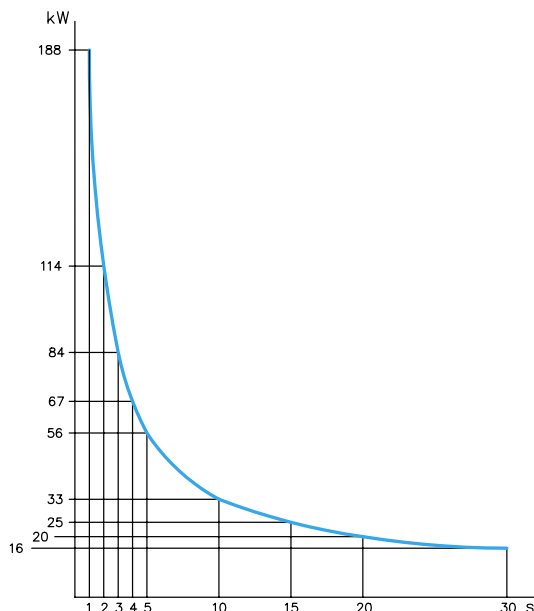

G

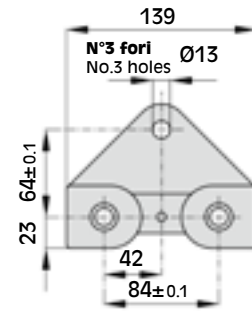

Vista base di montaggio  
View on caliper base

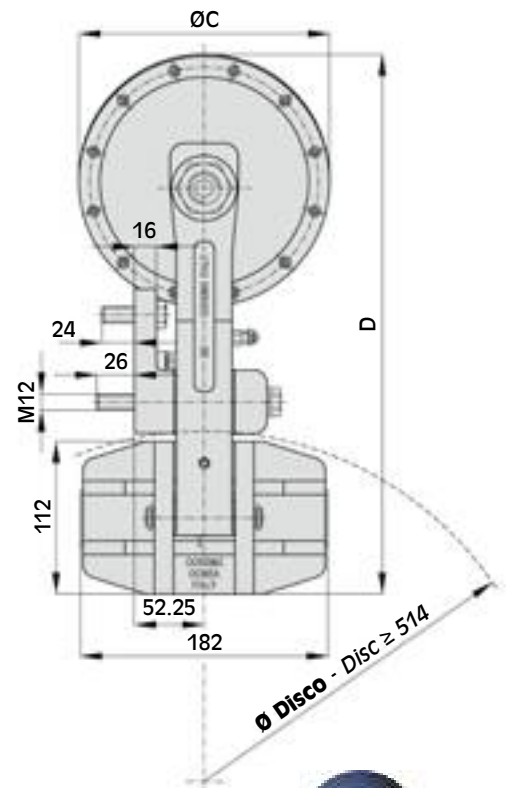
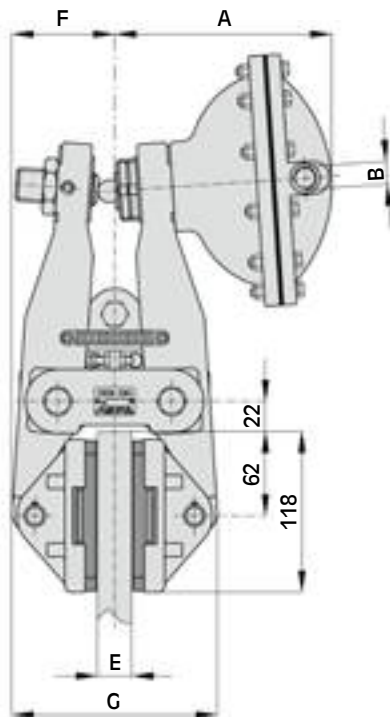

DIMENSIONI/DIMENSIONS

TIPO SIZE	Cod. Prodotto Product Number	A	B	ØC	D	E	F	G	Volume aria Air Volume dm <sup>3</sup>	Peso Weight kg
G1	A2149	119	1/4" gas	116	360	25.4	75.5	151	0.1	15.7
	A2846	127	1/4" gas	116	360	40	85.5	165.5	0.1	15.7
G2	A2152	141	3/8" gas	142	374	25.4	75.5	151	0.2	16.5
	A2850	149	3/8" gas	142	374	40	85.5	165.5	0.2	16.5
G3	A2155	159.5	3/8" gas	184	397	25.4	75.5	151	0.4	17.7
	A2333	167	3/8" gas	184	397	40	85.5	165.5	0.4	17.7
G3.5	A2158	189.5	1/2" gas	214	414	25.4	75.5	151	0.9	20.5
	A2858	197	1/2" gas	214	414	40	86	165.5	0.9	20.5

Attenzione: La coppia iniziale può essere dal 30% al 50% in meno rispetto al valore nominale, fino all'assestamento del ferodo sul disco.

Warning: The initial torque on new units can be 30% to 50% less than the catalogue value until the friction facing and friction disc are lapped or worn in.

## Dati tecnici

Forza tangenziale F:

<b>G1</b>	3610 N a 6 bar
<b>G2</b>	7200 N a 6 bar
<b>G3</b>	12500 N a 6 bar
<b>G3.5</b>	19000 N a 6 bar

Coppia dinamica  
 $= F \cdot (\text{raggio del disco in m} - 0.062) = \text{Nm}$

Usura max totale: 10 mm

Spessore del ferodo nuovo: 8 mm

Dissipazione del calore in continuo  
 QC: 14 kW

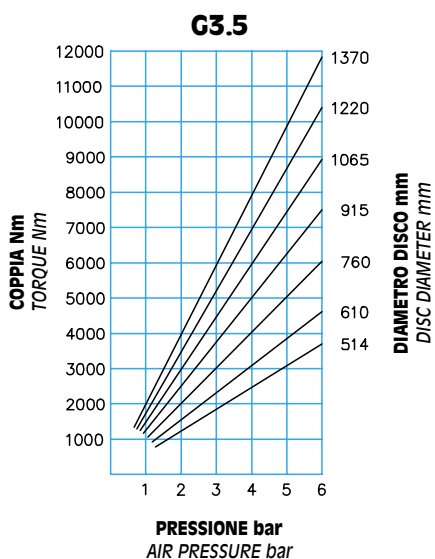
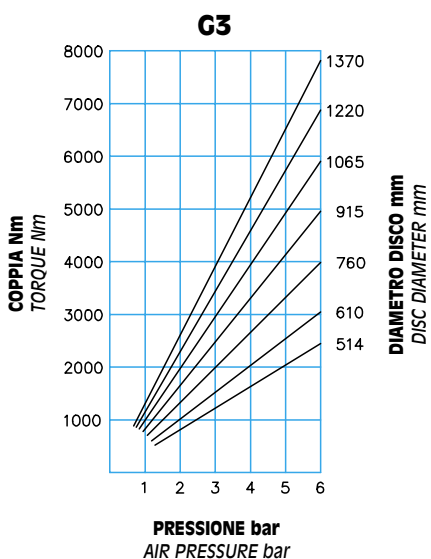
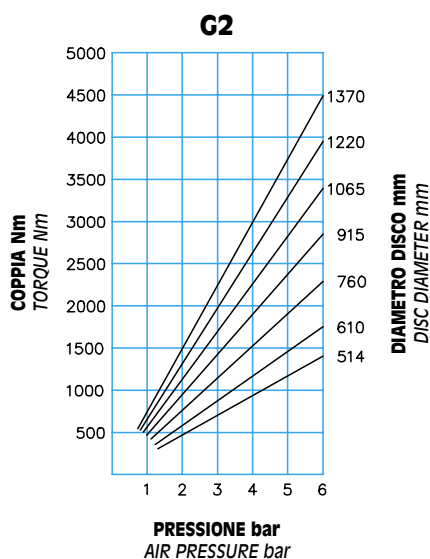
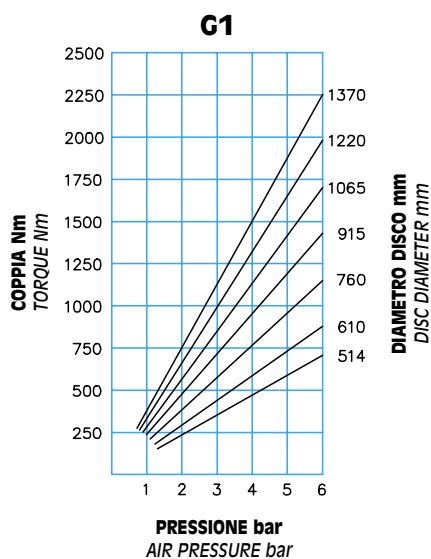

## Technical data

Braking force F:

<b>G1</b>	3610 N at 6 bar
<b>G2</b>	7200 N at 6 bar
<b>G3</b>	12500 N at 6 bar
<b>G3.5</b>	19000 N at 6 bar

Dynamic torque  
 $= F \cdot (\text{disc radius in m} - 0.062) = \text{Nm}$

Max total wear: 10 mm

Thickness of new lining: 8 mm

Continuous thermal capacity  
 QC: 14 kW

## DIAGRAMMA/CHART

**Dissipazione di calore per frenatura di emergenza**

*Thermal capacity for emergency stop*

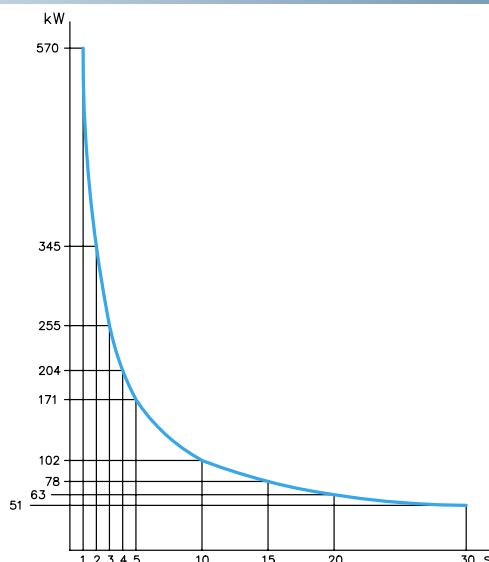



# PNEUMATICI Negativi



# PNEUMATIC Failsafe brakes

**La necessità di frenare e bloccare le parti rotanti delle macchine impone la ricerca di un dispositivo funzionante senza nessuna fonte di energia esterna. I freni negativi della Coremo Ocmea sono la soluzione del problema; la forza frenante è garantita dalle molle presenti all'interno del freno.**

*The need to stop any machine rotating part will force you to select a device working without any external power supply. Coremo spring applied caliper brakes are the solution of this problem; braking force is always available due to springs mounted in the brake.*

SPRING APPLIED PNEUMATICALLY RELEASED



# MPA-N

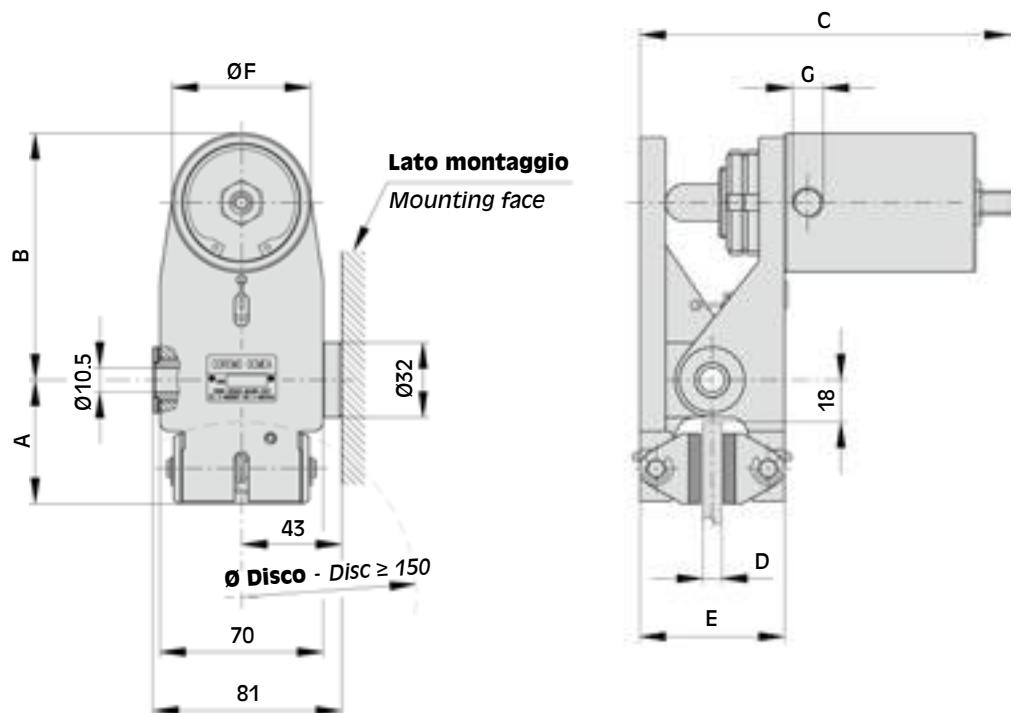

## DIMENSIONI/DIMENSIONS



TIPO SIZE	Cod. Prodotto Product Number	A	B	C		D	E	ØF	G	Volume aria Air Volume dm <sup>3</sup>	Peso Weight kg
				min	max						
MPA-N	A2928	53	106	159	177	8	62	59.5	1/4"gas	0.025	2
	A2930	52	113	167	176	12.7	68	59.5	1/4"gas	0.025	2
MPA-1N	A2932	53	125	210	228	8	62	98	1/4"gas	0.16	3.8
	A2934	52	136	218	228	12.7	69	98	1/4"gas	0.16	3.8

**Attenzione:** La coppia iniziale può essere dal 30% al 50% in meno rispetto al valore nominale, fino all'assestamento del ferodo sul disco.

**Warning:** The initial torque on new units can be 30% to 50% less than the catalogue value until the friction facing and friction disc are lapped or worn in.

## Dati tecnici

Forza tangenziale F:

**MPA-N** 970 N  
**MPA-1N** 2750 N

Coppia dinamica  
=  $F \cdot (\text{raggio del disco in m} - 0.024) = \text{Nm}$

Usura max totale: 6 mm

Spessore del ferodo nuovo: 5 mm

Dissipazione del calore in continuo  
QC: 1 kW

Pressione minima di apertura: 4.5 bar

I valori di coppia indicati sono ottenuti con

n. 3 molle per MPA-N,  
n. 4 molle per MPA-1N.

Il grafico rappresenta l'andamento della coppia per ogni millimetro di usura dei ferodi.

Per ripristinare il valore nominale della coppia intervenire sul sistema di regolazione.

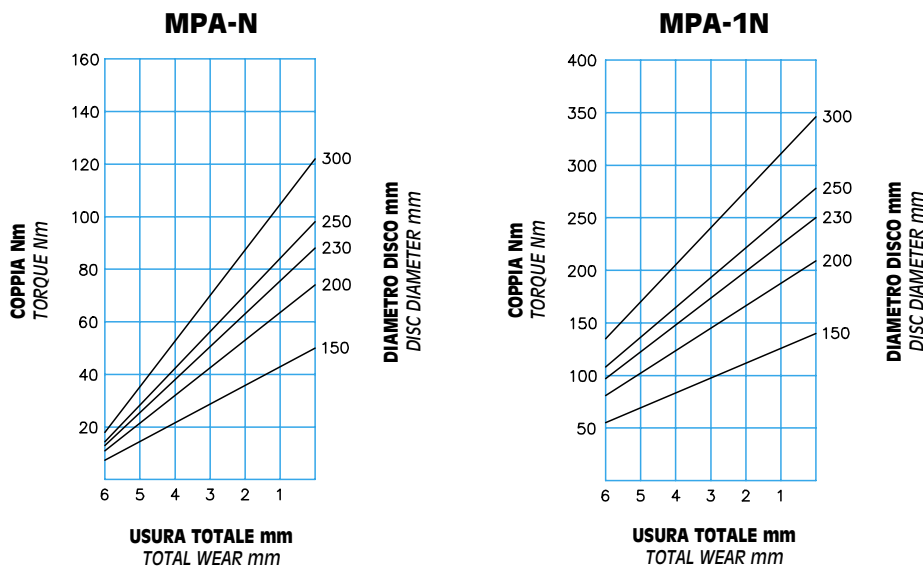

## DIAGRAMMA/CHART

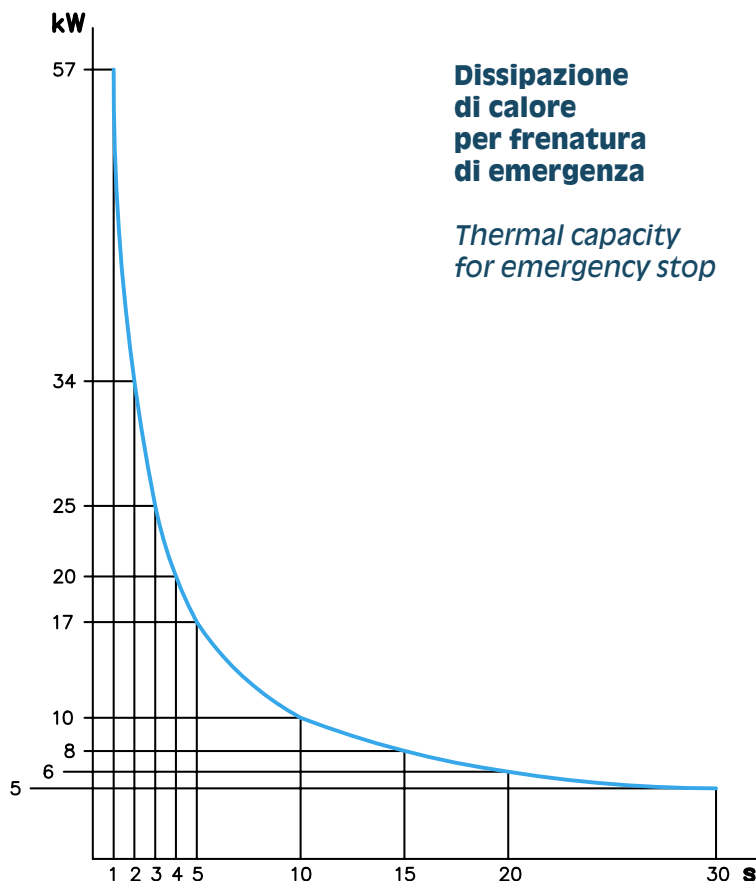

## Technical data

Braking force F:

**MPA-N** 970 N  
**MPA-1N** 2750 N

Dynamic torque  
=  $F \cdot (\text{disc radius in m} - 0.024) = \text{Nm}$

Max total wear: 6 mm

Thickness of new lining: 5 mm

Continuous thermal capacity  
QC: 1 kW

Minimum release pressure: 4.5 bar

The torque values specified are obtained with

n. 3 springs for MPA-N,  
n. 4 springs for MPA-1N.

The diagram shows the torque variation for each millimeter of linings wear.

Adjust according to ensure the correct torque value is achieved.

A-N

Disponibile anche per disco spessore 25,4 - 30 - 40 mm.  
Available also for disc thickness 25,4 - 30 - 40 mm.



Versione pattino doppio  
Double pad version

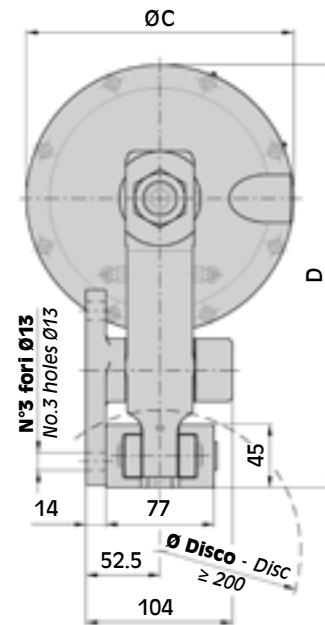
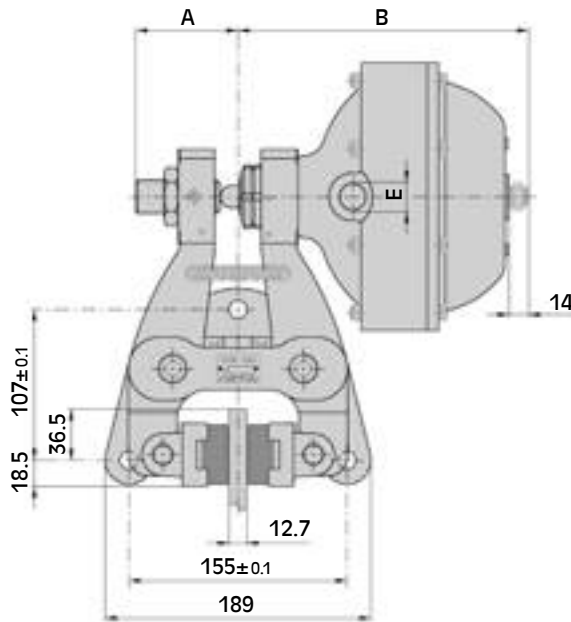
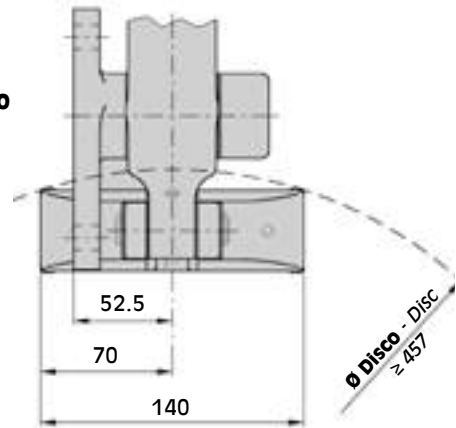

DIMENSIONI/DIMENSIONS



TIPO SIZE	Cod. Prodotto Product Number		A	B	ØC	D	E	Volume aria Air Volume dm <sup>3</sup>	Peso Weight kg
	S.P.	S.U.							
A-1N	A3274	A3276	70.5	188.5	98	254.5	1/4" gas	0.16	12.6
A-2N	A3282	A3284	72.5	178.5	144	277.5	1/2" gas	0.3	13.6
A-3N	A3290	A3292	72.5	206.5	190	300.5	1/2" gas	0.5	16.8
<p>S.P. = Produzione Standard / Standard Production S.U. = Con segnalatore di usura / With Wear Indicator</p>									

Attenzione: La coppia iniziale può essere dal 30% al 50% in meno rispetto al valore nominale, fino all'assestamento del ferodo sul disco.

Warning: The initial torque on new units can be 30% to 50% less than the catalogue value until the friction facing and friction disc are lapped or worn in.

## Dati tecnici

Forza tangenziale F:

A-1N	2750 N
A-2N	5500 N
A-3N	10970 N

Coppia dinamica  
 $= F \cdot (\text{raggio del disco in m} - 0.03) = Nm$

Usura max totale: 16 mm

Spessore del ferodo nuovo: 16 mm

Dissipazione del calore in continuo  
 QC: 1.7 kW

Dissipazione di calore in continuo  
 con pattino doppio QC: 2.7 kW

Pressione minima di apertura: 5 bar

I valori di coppia indicati sono  
 ottenuti con n. 4 molle per 1N,  
 n. 8 molle per 2N e 3N.

Coppie proporzionalmente inferiori si  
 possono ottenere con n. 2 molle per 1N,  
 n. 6-4-2 molle per 2N e 3N.

Il grafico rappresenta l'andamento  
 della coppia per ogni millimetro  
 di usura dei ferodi.

Per ripristinare il valore nominale  
 della coppia intervenire sul sistema  
 di regolazione.

## Technical data

Braking force F:

A-1N	2750 N
A-2N	5500 N
A-3N	10970 N

Dynamic torque  
 $= F \cdot (\text{disc radius in m} - 0.03) = Nm$

Max total wear: 16 mm

Thickness of new lining: 16 mm

Continuous thermal capacity  
 QC: 1.7 kW

Continuous thermal capacity  
 for double pad version  
 QC: 2.7 kW

Minimum release pressure: 5 bar

The torque values specified  
 are obtained with n. 4 springs for 1N,  
 n. 8 springs for 2N and 3N.

Torque proportionally less are  
 achievable with n. 2 springs for 1N,  
 n. 6-4-2 springs for 2N and 3N.

The diagram shows the torque  
 variation for each millimeter  
 of linings wear.

Adjust according to ensure the  
 correct torque value is achieved.

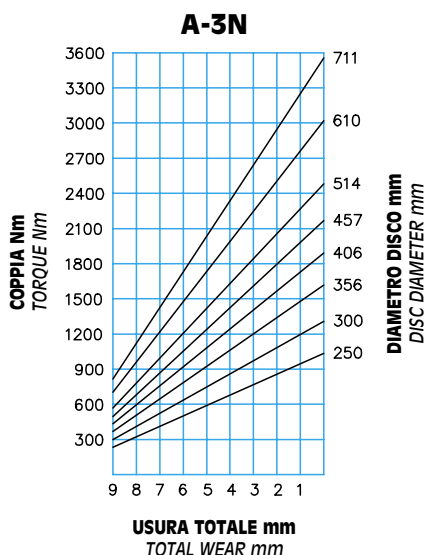
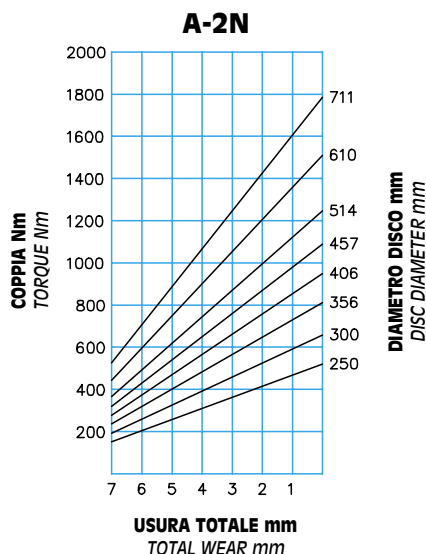
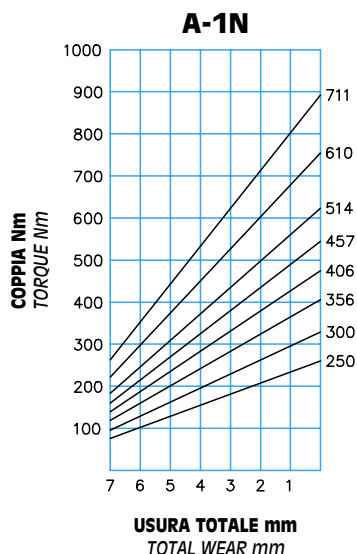

## DIAGRAMMA/CHART

Dissipazione  
 di calore  
 per frenatura  
 di emergenza

Thermal capacity  
 for emergency stop

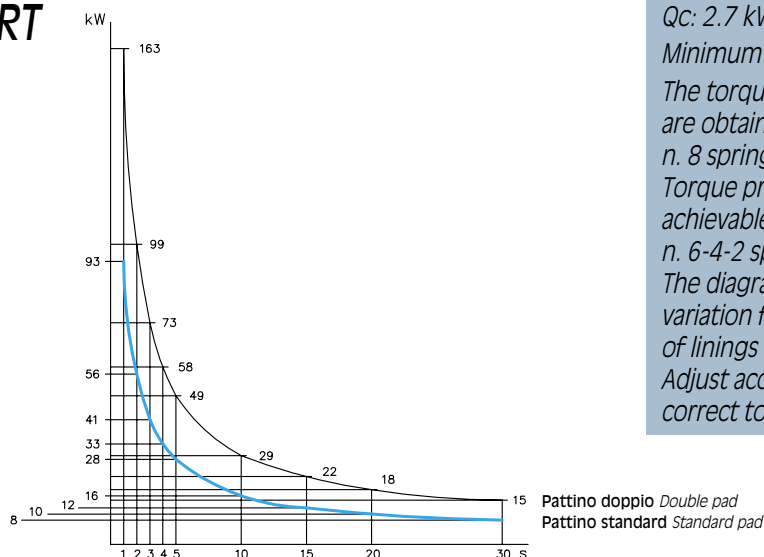

# B-N



**SCHEMA DI MONTAGGIO**  
Mounting positions

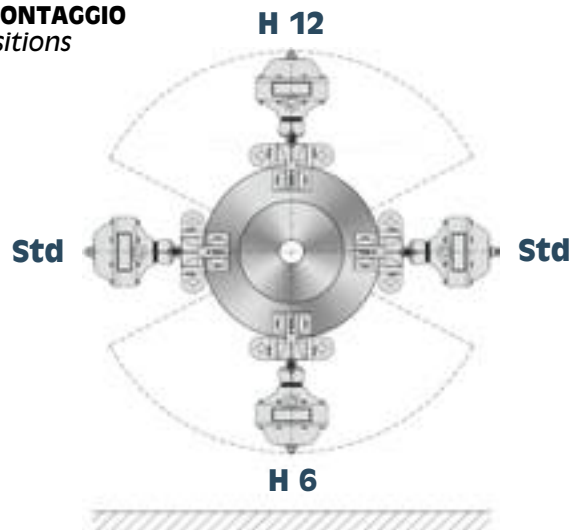

**Versione pattino doppio**  
Double pad version

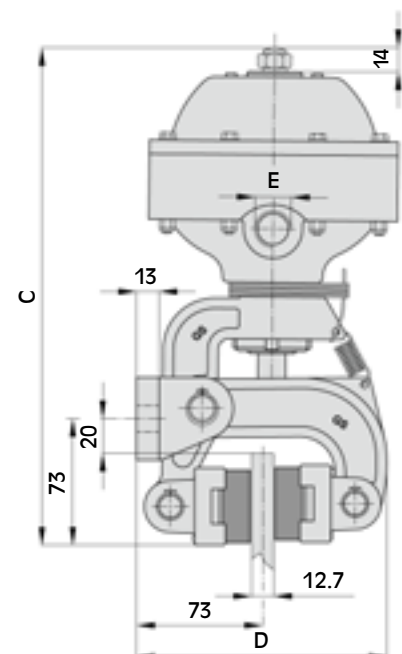
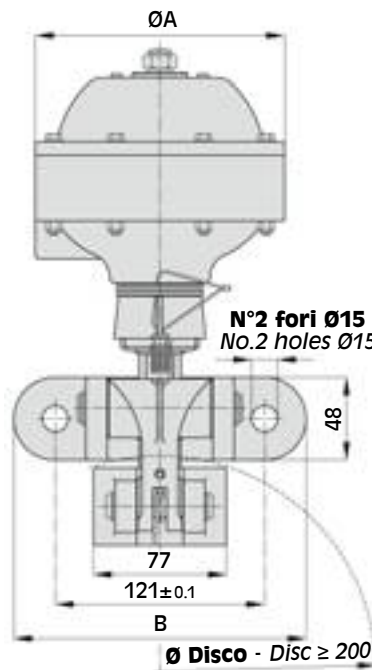
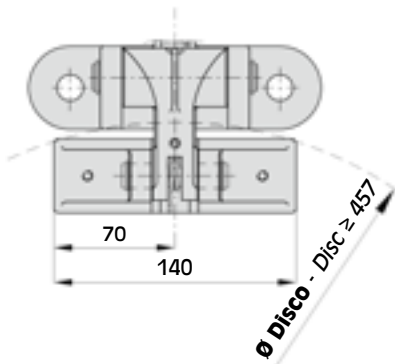

## DIMENSIONI/DIMENSIONS



TIPO SIZE	Cod. Prodotto Product Number						ØA	B	C	D	E	Volume aria Air Volume dm <sup>3</sup>	Peso Weight kg
	Std.	Std. S.U.	H6	H6 S.U.	H12	H12 S.U.							
<b>B-1N</b>	A2242	A2243	A2286	A2287	A2290	A2291	98	169	290	145	1/4"gas	0.16	7
<b>B-2N</b>	A2032	A2033	A2050	A2051	A2068	A2069	144	169	288.5	145	1/2"gas	0.3	8.1
<p><b>S.P. = Produzione Standard / Standard Production</b>  <b>S.U. = Con segnalatore di usura / With Wear Indicator</b></p>													

**Attenzione:** La coppia iniziale può essere dal 30% al 50% in meno rispetto al valore nominale, fino all'assestamento del ferodo sul disco.

**Warning:** The initial torque on new units can be 30% to 50% less than the catalogue value until the friction facing and friction disc are lapped or worn in.

## Dati tecnici

Forza tangenziale F:

<b>B-1N</b>	1300 N
<b>B-2N</b>	2600 N

Coppia dinamica  
 $= F \cdot (\text{raggio del disco in m} - 0.032) = \text{Nm}$

Usura max totale: 14 mm

Spessore del ferodo nuovo: 16 mm

Dissipazione del calore in continuo  
 Qc: 1.7 kW

Dissipazione di calore in continuo  
 con pattino doppio Qc: 2.7 kW

Pressione minima di apertura: 5 bar

I valori di coppia indicati sono  
 ottenuti con n. 4 molle per 1N,  
 n. 8 molle per 2N e 3N.

Coppie proporzionalmente inferiori  
 si possono ottenere con n. 2 molle per 1N,  
 n. 6-4-2 molle per 2N e 3N.

Il grafico rappresenta l'andamento  
 della coppia per ogni 2 millimetri  
 di usura dei ferodi.

Per ripristinare il valore nominale  
 della coppia intervenire sul sistema  
 di regolazione.

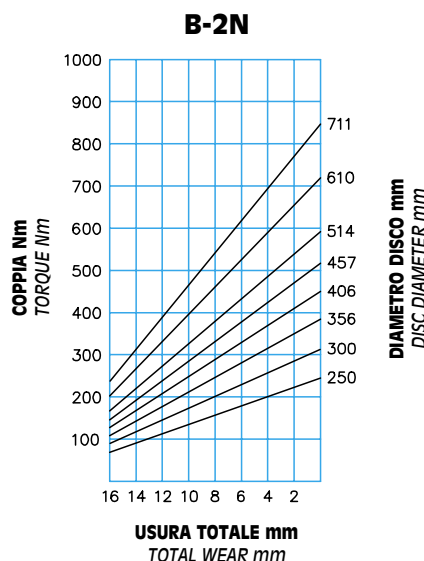
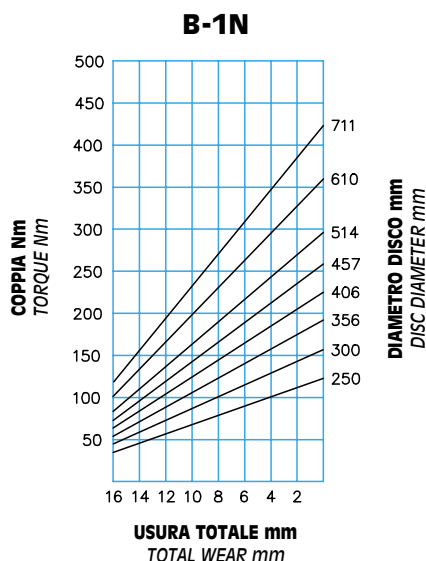

## DIAGRAMMA/CHART

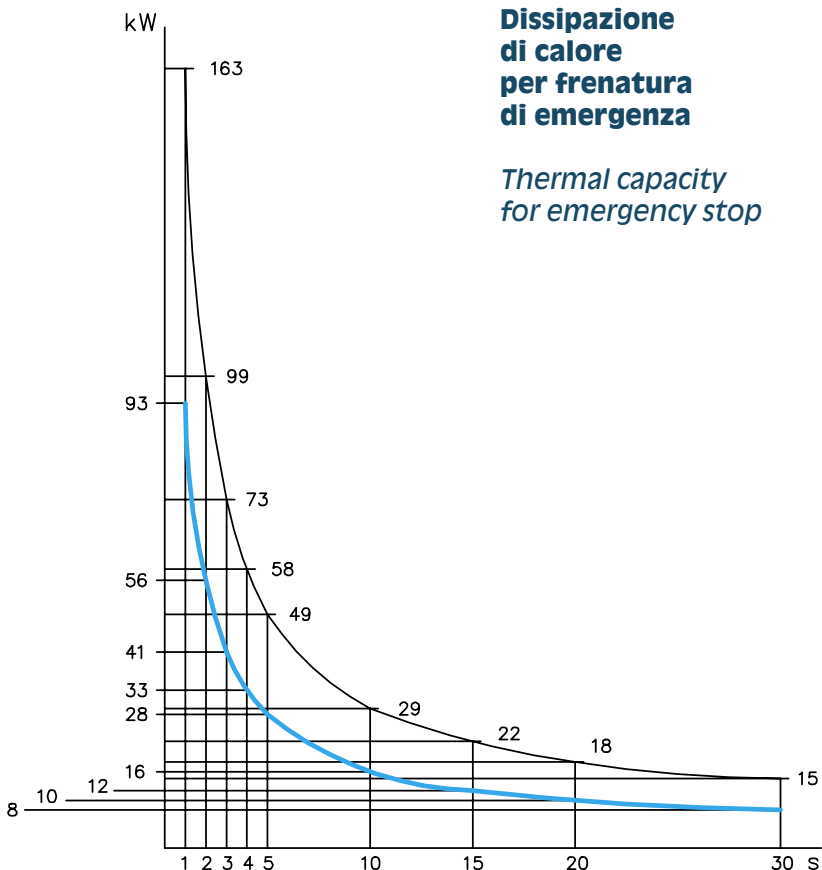

## Technical data

Braking force F:

<b>B-1N</b>	1300 N
<b>B-2N</b>	2600 N

Dynamic torque  
 $= F \cdot (\text{disc radius in m} - 0.032) = \text{Nm}$

Max total wear: 14 mm

Thickness of new lining: 16 mm

Continuous thermal capacity  
 Qc: 1.7 kW

Continuous thermal capacity  
 for double pad version  
 Qc: 2.7 kW

Minimum release pressure: 5 bar

The torque values specified  
 are obtained with n. 4 springs for 1N,  
 n. 8 springs for 2N and 3N.

Torque proportionally less  
 are achievable with n. 2 springs for 1N,  
 n. 6-4-2 springs for 2N and 3N.  
 The diagram shows the torque  
 variation for 2 millimeters of lining wear.  
 Adjust according to ensure the  
 correct torque value is achieved.

# D-N

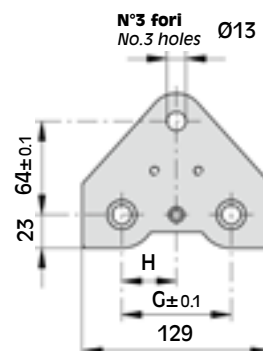

Vista base di montaggio  
View on caliper base

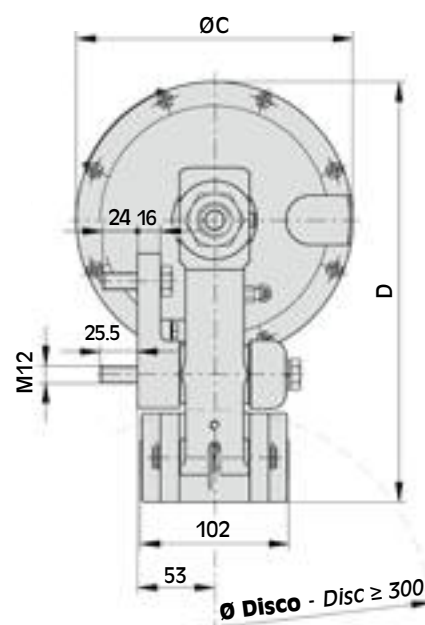
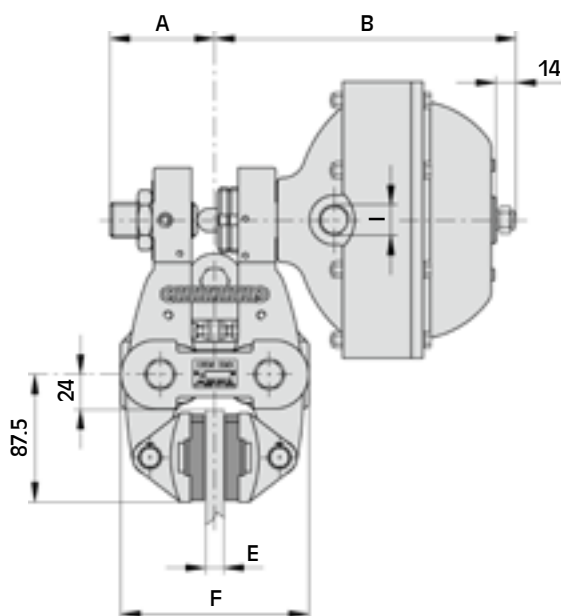

## DIMENSIONI/DIMENSIONS



TIPO SIZE	Cod. Prodotto Product Number	A	B	ØC	D	E	F	G	H	I	Volume aria Air Volume dm <sup>3</sup>	Peso Weight kg
D-1N	A2526	70	189	98	242.5	12.7	129	75	37.5	1/4"gas	0.16	11.3
	A2534	69.5	190	98	246.5	25.4	132	84	42	1/4"gas	0.16	11.3
	A2542	81	198	98	242.5	30	140	75	37.5	1/4"gas	0.16	11.3
	A2550	76.5	202.5	98	242.5	40	149	84	42	1/4"gas	0.16	11.3
D-2N	A2558	72	179	144	265.5	12.7	129	75	37.5	1/2"gas	0.3	12.3
	A2566	71.5	180	144	268	25.4	132	84	42	1/2"gas	0.3	12.3
	A2574	83	188	144	265.5	30	140	75	37.5	1/2"gas	0.3	12.3
	A2582	78.5	192.5	144	265.5	40	149	84	42	1/2"gas	0.3	12.3
D-3N	A2590	72	207	190	288.5	12.7	129	75	37.5	1/2"gas	0.7	15.4
	A2598	71.5	208	190	292	25.4	132	84	42	1/2"gas	0.7	15.4
	A2606	83	216	190	288.5	30	140	75	37.5	1/2"gas	0.7	15.4
	A2614	78.5	220.5	190	288.5	40	149	84	42	1/2"gas	0.7	15.4

**Attenzione:** La coppia iniziale può essere dal 30% al 50% in meno rispetto al valore nominale, fino all'assestamento del ferodo sul disco.

**Warning:** The initial torque on new units can be 30% to 50% less than the catalogue value until the friction facing and friction disc are lapped or worn in.

## Dati tecnici

Forza tangenziale F:

D-1N	2625 N
D-2N	5250 N
D-3N	10400 N

Coppia dinamica  
 $= F \cdot (\text{raggio del disco in m} - 0.033) = \text{Nm}$   
 Usura max totale: 12 mm  
 Spessore del ferodo nuovo: 11 mm  
 Dissipazione del calore in continuo  
 Qc: 3.4 kW

Pressione minima di apertura: 5 bar  
 I valori di coppia indicati sono ottenuti con n. 4 molle per 1N, n. 8 molle per 2N e 3N. Coppie proporzionalmente inferiori si possono ottenere con n. 2 molle per 1N, n. 6-4-2 molle per 2N e 3N. Il grafico rappresenta l'andamento della coppia per ogni millimetro di usura dei ferodi. Per ripristinare il valore nominale della coppia intervenire sul sistema di regolazione.

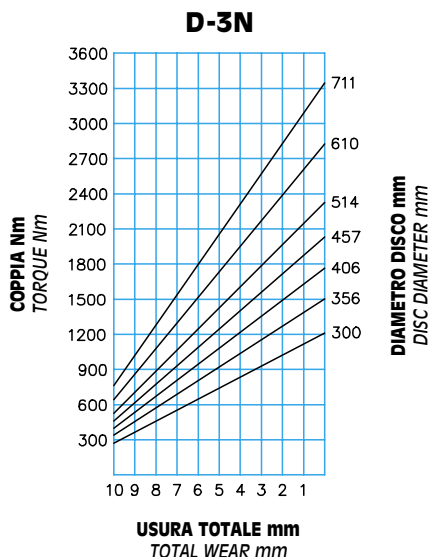
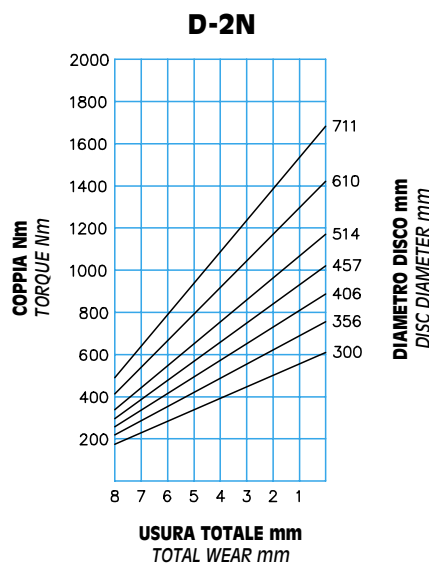
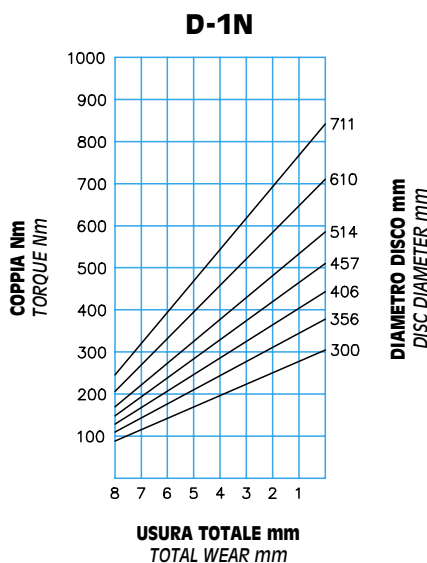

## Technical data

Braking force F:

D-1N	2625 N
D-2N	5250 N
D-3N	10400 N

Dynamic torque  
 $= F \cdot (\text{disc radius in m} - 0.033) = \text{Nm}$   
 Max total wear: 12 mm  
 Thickness of new lining: 11 mm  
 Continuous thermal capacity  
 Qc: 3.4 kW

Minimum release pressure: 5 bar

The torque values specified are obtained with n. 4 springs for 1N, n. 8 springs for 2N and 3N. Torque proportionally less are achievable with n. 2 springs for 1N, n. 6-4-2 springs for 2N and 3N. The diagram shows the torque variation for each millimeter of linings wear. Adjust according to ensure the correct torque value is achieved.

## DIAGRAMMA/CHART

**Dissipazione di calore per frenatura di emergenza**

Thermal capacity for emergency stop

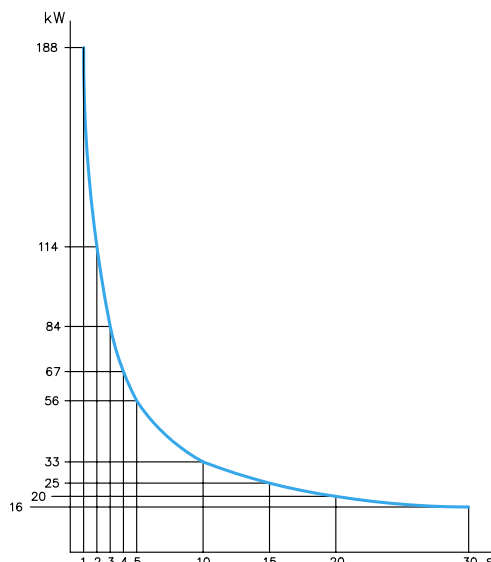

# E-N

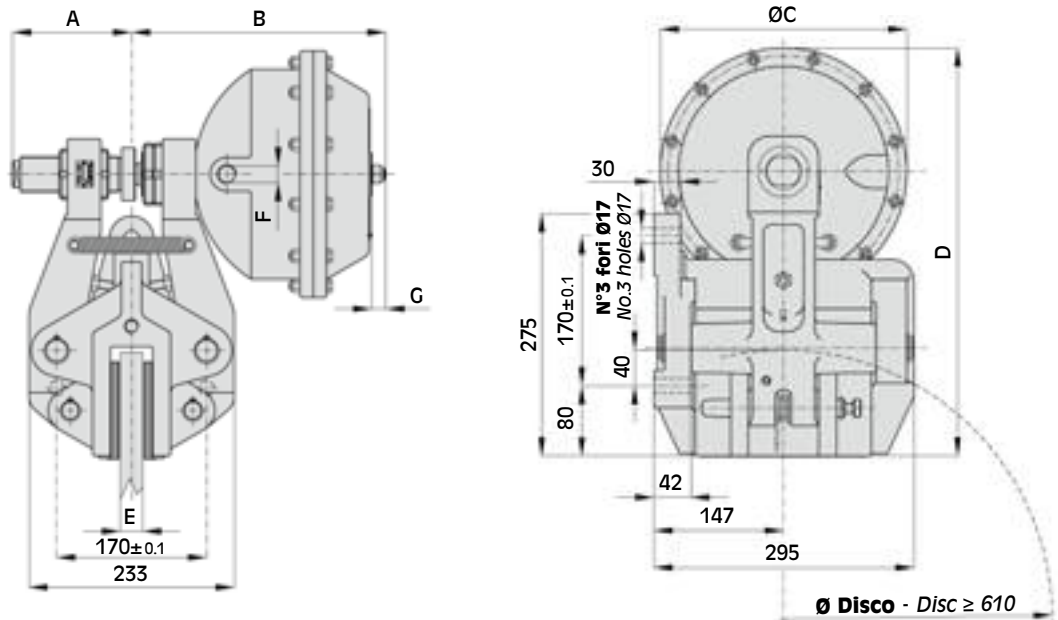

## DIMENSIONI/DIMENSIONS



TIPO SIZE	Cod. Prodotto Product Number	A	B	ØC	D	E	F	G	Volume aria Air Volume dm <sup>3</sup>	Peso Weight kg
E-3N	A1967	126	227	190	418	25.4	1/2"gas	14	0.7	61
	A1970	126	227	190	418	40	1/2"gas	14	0.7	61
E-3.5N	A2874	127	242	240	443	25.4	1/2"gas	16	0.95	65.5
	A2877	127	242	240	443	40	1/2"gas	16	0.95	65.5
E-4N	A1973	135	289	280	463	25.4	1/2"gas	16	3	70
	A1976	135	289	280	463	40	1/2"gas	16	3	70

**Attenzione:** La coppia iniziale può essere dal 30% al 50% in meno rispetto al valore nominale, fino all'assestamento del ferodo sul disco.

**Warning:** The initial torque on new units can be 30% to 50% less than the catalogue value until the friction facing and friction disc are lapped or worn in.

## Dati tecnici

Forza tangenziale F:

<b>E-3N</b>	14150 N
<b>E-3.5N</b>	26600 N
<b>E-4N</b>	32000 N

Coppia dinamica  
 $= F \cdot (\text{raggio del disco in m} - 0.065) = \text{Nm}$

Usura max totale: 12 mm

Spessore del ferodo nuovo: 13 mm

Dissipazione del calore in continuo  
 Qc: 20 kW

Pressione minima di apertura: 5 bar

I valori di coppia indicati sono ottenuti con:

n. 8 molle per 3N,  
 n. 12 molle per 3.5N e 4N.

Coppie proporzionalmente inferiori si possono ottenere con:

n. 6-4-2 molle per 3N,  
 n. 10-8-6 molle per 3.5N e 4N.

Il grafico rappresenta l'andamento della coppia per ogni millimetro di usura dei ferodi.

Per ripristinare il valore nominale della coppia intervenire sul sistema di regolazione.

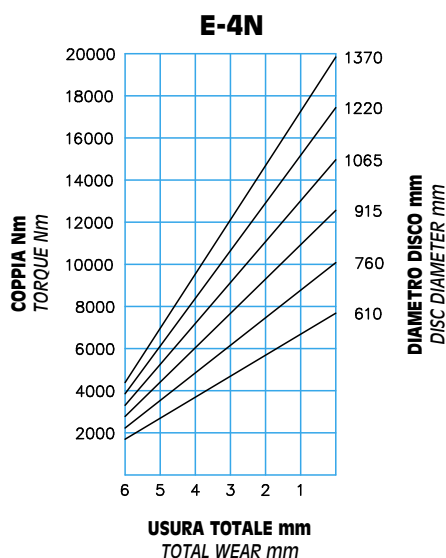
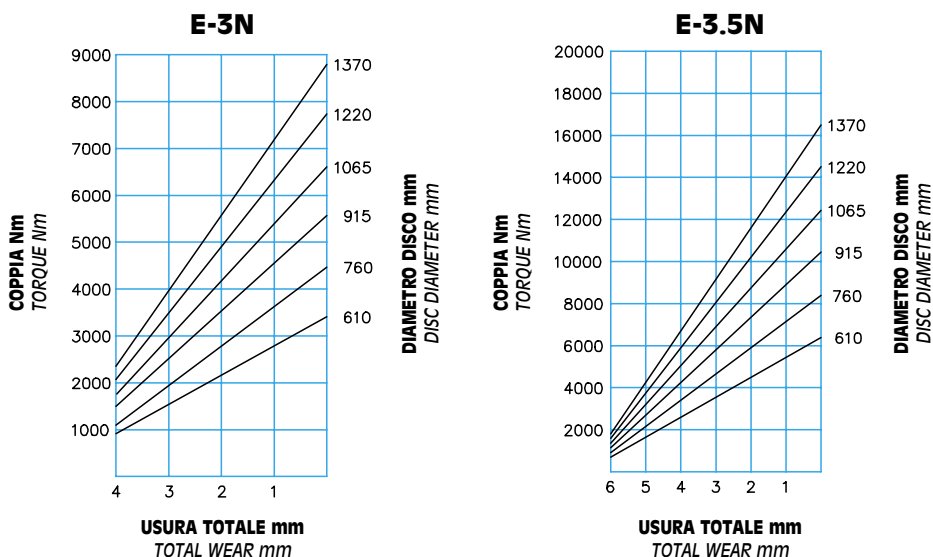

## DIAGRAMMA/CHART

**Dissipazione di calore per frenatura di emergenza**

*Thermal capacity for emergency stop*

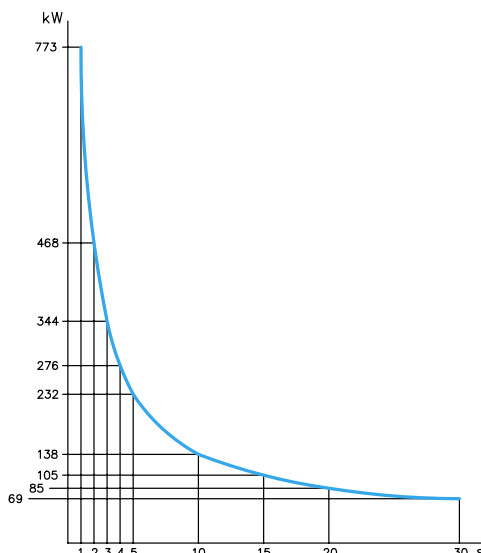

## Technical data

Braking force F:

<b>E-3N</b>	14150 N
<b>E-3.5N</b>	26600 N
<b>E-4N</b>	32000 N

Dynamic torque  
 $= F \cdot (\text{disc radius in m} - 0.065) = \text{Nm}$

Max total wear: 12 mm

Thickness of new lining: 13 mm

Continuous thermal capacity  
 Qc: 20 kW

Minimum release pressure: 5 bar

The torque values specified are obtained with

No. 8 springs for 3N,  
 No. 12 springs for 3.5N and 4N.

Torque proportionally less are achievable with

No. 6-4-2 springs for 3N,  
 No. 10-8-6 springs for 3.5N and 4N.

The diagram shows the torque variation for each millimeter of linings wear.

Adjust according to ensure the correct torque value is achieved.

# EL-N

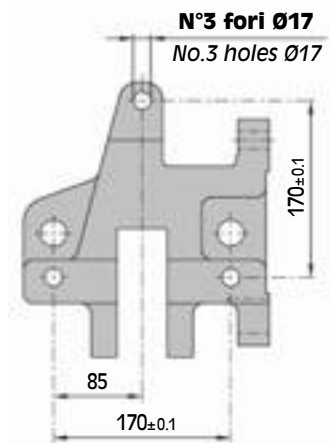

Vista montaggio frontale  
Frontal mounting view

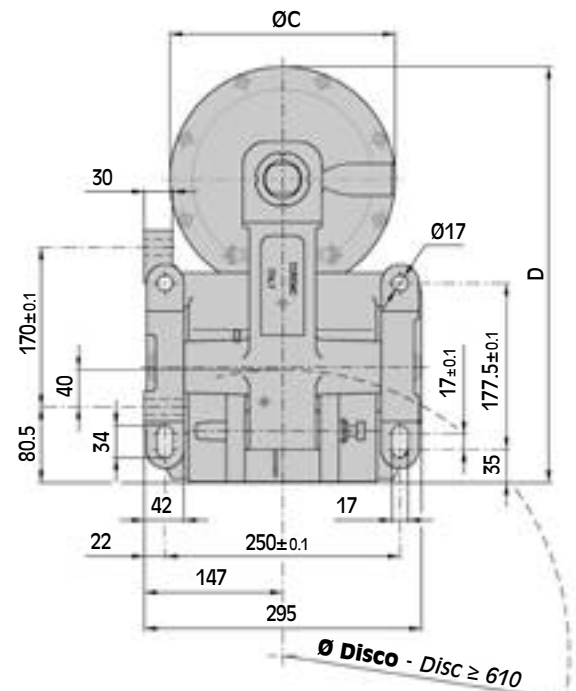
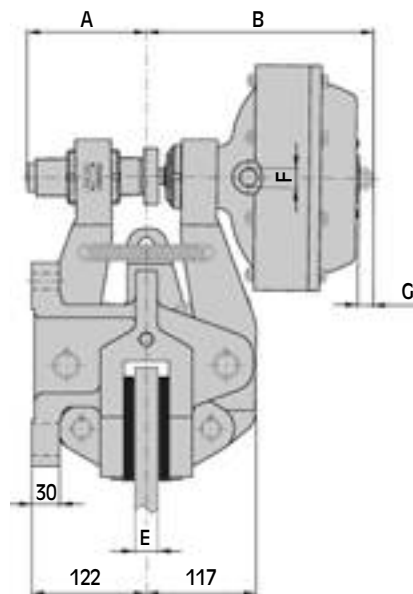

## DIMENSIONI/DIMENSIONS



TIPO SIZE	Cod. Prodotto Product Number	A	B	ØC	D	E	F	G	Volume aria Air Volume dm <sup>3</sup>	Peso Weight kg
EL-3N	A3587	126	227	190	418	25.4	1/2"gas	14	0.7	64
	A3590	126	227	190	418	40	1/2"gas	14	0.7	64
EL-3.5N	A3593	127	242	240	443	25.4	1/2"gas	16	0.95	68.5
	A3596	127	242	240	443	40	1/2"gas	16	0.95	68.5
EL-4N	A3599	135	289	280	463	25.4	1/2"gas	16	3	73
	A3602	135	289	280	463	40	1/2"gas	16	3	73

**Attenzione:** La coppia iniziale può essere dal 30% al 50% in meno rispetto al valore nominale, fino all'assestamento del ferodo sul disco.

**Warning:** The initial torque on new units can be 30% to 50% less than the catalogue value until the friction facing and friction disc are lapped or worn in.

## Dati tecnici

Forza tangenziale F:

EL-3N	14150 N
EL-3.5N	26600 N
EL-4N	32000 N

Coppia dinamica  
 $= F \cdot (\text{raggio del disco in m} - 0.065) = \text{Nm}$

Usura max totale: 12 mm

Spessore del ferodo nuovo: 13 mm

Dissipazione del calore in continuo  
 Qc: 20 kW

Pressione minima di apertura: 5 bar

I valori di coppia indicati sono ottenuti con:

n. 8 molle per 3N,  
 n. 12 molle per 3.5N e 4N.

Coppie proporzionalmente inferiori si possono ottenere con:

n. 6-4-2 molle per 3N,  
 n. 10-8-6 molle per 3.5N e 4N.

Il grafico rappresenta l'andamento della coppia per ogni millimetro di usura dei ferodi.

Per ripristinare il valore nominale della coppia intervenire sul sistema di regolazione.

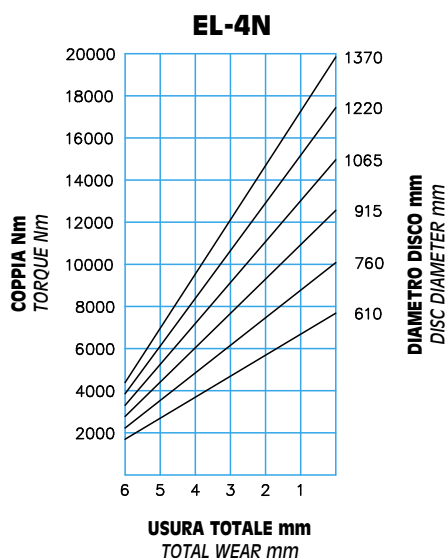
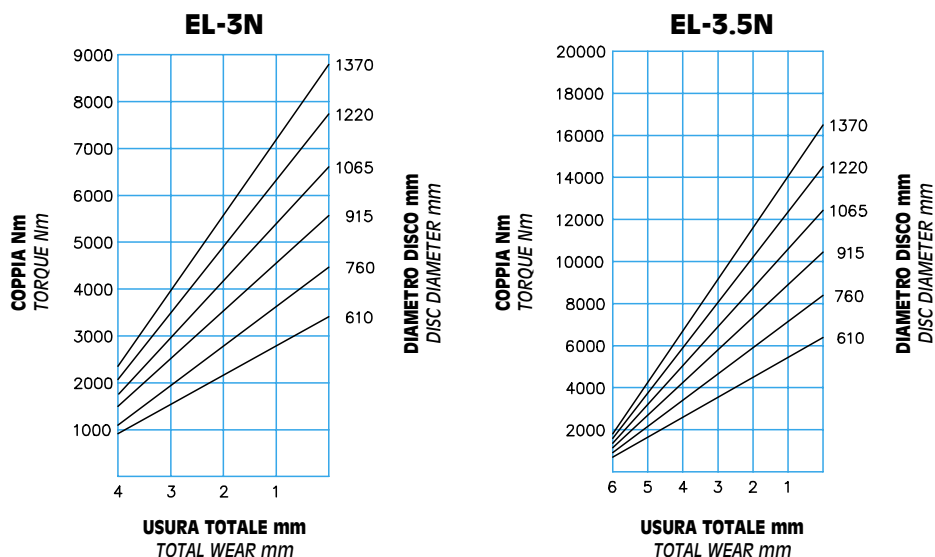

## DIAGRAMMA/CHART

**Dissipazione di calore per frenatura di emergenza**

*Thermal capacity for emergency stop*

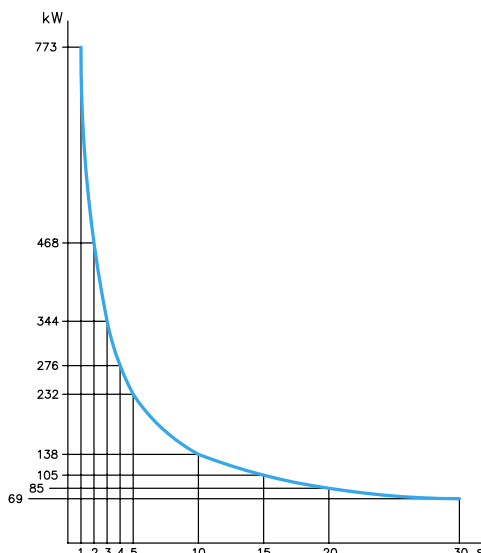

## Technical data

Braking force F:

EL-3N	14150 N
EL-3.5N	26600 N
EL-4N	32000 N

Dynamic torque  
 $= F \cdot (\text{disc radius in m} - 0.065) = \text{Nm}$

Max total wear: 12 mm

Thickness of new lining: 13 mm

Continuous thermal capacity  
 Qc: 20 kW

Minimum release pressure: 5 bar

The torque values specified are obtained with

No. 8 springs for 3N,  
 No. 12 springs for 3.5N and 4N.

Torque proportionally less are achievable with

No. 6-4-2 springs for 3N,  
 No. 10-8-6 springs for 3.5N and 4N.

The diagram shows the torque variation for each millimeter of linings wear.

Adjust according to ensure the correct torque value is achieved.

F-N

Disponibile anche per disco spessore 25,4 - 30 - 40 mm.  
Available also for disc thickness 25,4 - 30 - 40 mm.

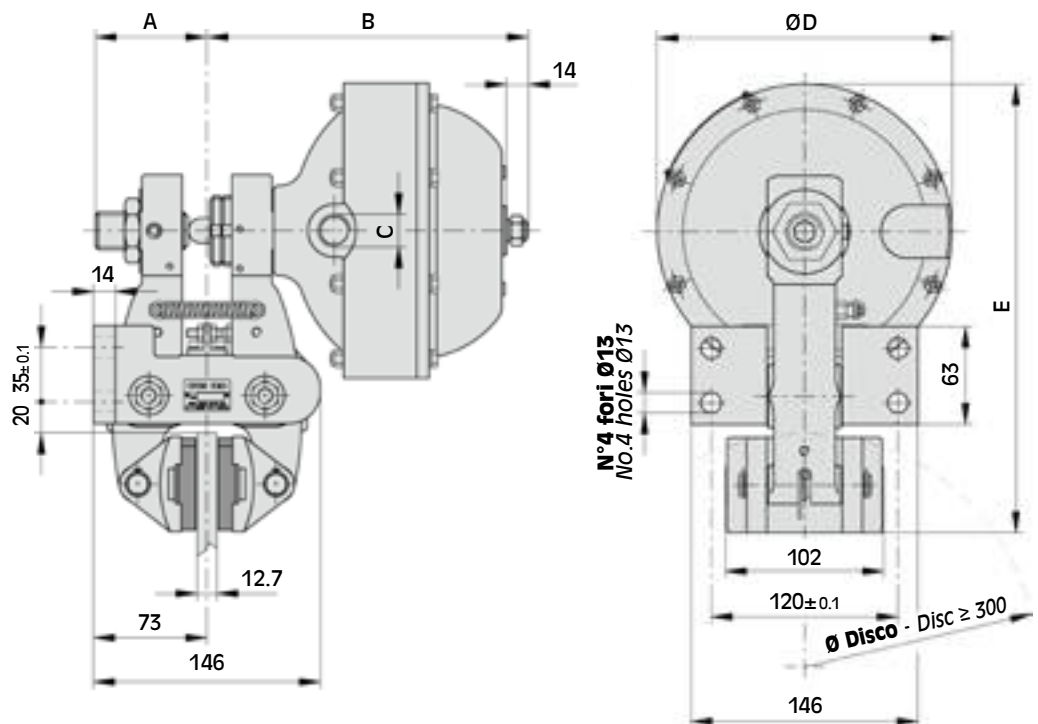

DIMENSIONI/DIMENSIONS



TIPO SIZE	Cod. Prodotto Product Number	A	B	C	ØD	E	Volume aria Air Volume dm <sup>3</sup>	Peso Weight kg
F-1N	A2790	70	189	1/4"gas	98	242.5	0.16	11
F-2N	A2798	72	179	1/2"gas	144	265.5	0.3	12
F-3N	A2806	72	207	1/2"gas	190	288.5	0.7	15.1

**Attenzione:** La coppia iniziale può essere dal 30% al 50% in meno rispetto al valore nominale, fino all'assestamento del ferodo sul disco.

**Warning:** The initial torque on new units can be 30% to 50% less than the catalogue value until the friction facing and friction disc are lapped or worn in.

## Dati tecnici

Forza tangenziale F:

<b>F-1N</b>	2625 N
<b>F-2N</b>	5250 N
<b>F-3N</b>	10400 N

Coppia dinamica  
 $= F \cdot (\text{raggio del disco in m} - 0.033) = \text{Nm}$

Usura max totale: 12 mm

Spessore del ferodo nuovo: 11 mm

Dissipazione del calore in continuo  
 Qc: 3.4 kW

Pressione minima di apertura: 5 bar

I valori di coppia indicati sono ottenuti con n. 4 molle per 1N, n. 8 molle per 2N e 3N.

Coppie proporzionalmente inferiori si possono ottenere con n. 2 molle per 1N, n. 6-4-2 molle per 2N e 3N.

Il grafico rappresenta l'andamento della coppia per ogni millimetro di usura dei ferodi.

Per ripristinare il valore nominale della coppia intervenire sul sistema di regolazione.

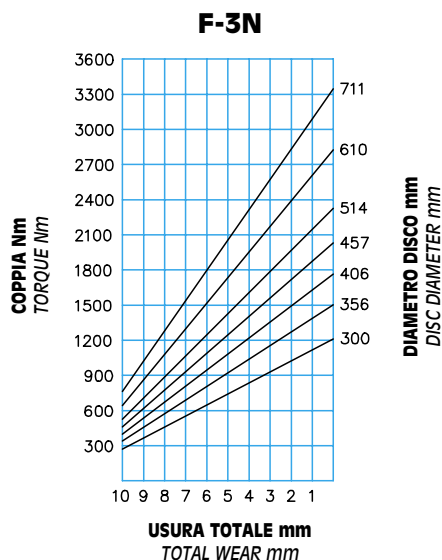
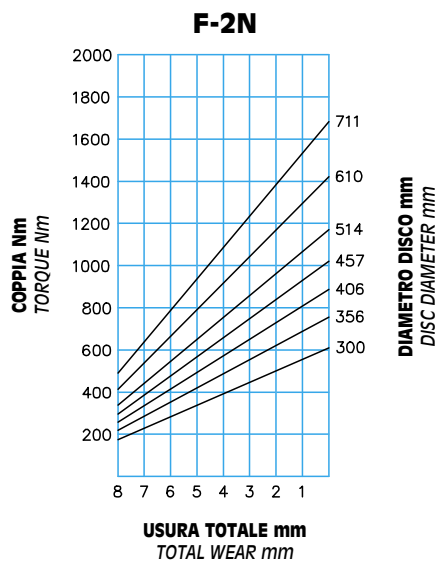
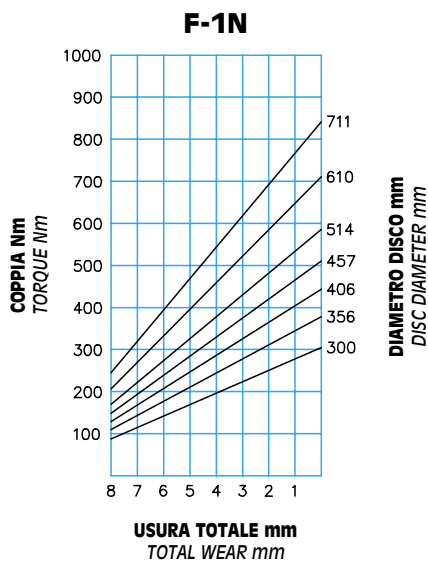

## Technical data

Braking force F:

<b>F-1N</b>	2625 N
<b>F-2N</b>	5250 N
<b>F-3N</b>	10400 N

Dynamic torque  
 $= F \cdot (\text{disc radius in m} - 0.033) = \text{Nm}$

Max total wear: 12 mm

Thickness of new lining: 11 mm

Continuous thermal capacity  
 Qc: 3.4 kW

Minimum release pressure: 5 bar

The torque values specified are obtained with n. 4 springs for 1N, n. 8 springs for 2N and 3N.

Torque proportionally less are achievable with n. 2 springs for 1N, n. 6-4-2 springs for 2N and 3N.

The diagram shows the torque variation for each millimeter of linings wear.

Adjust according to ensure the correct torque value is achieved.

## DIAGRAMMA/CHART

**Dissipazione di calore per frenatura di emergenza**

Thermal capacity for emergency stop

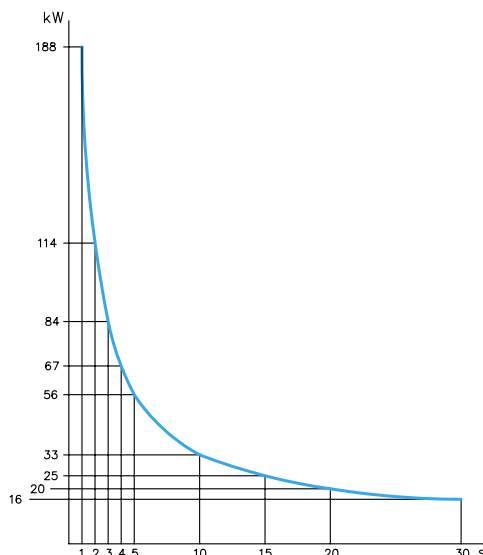

# G-N

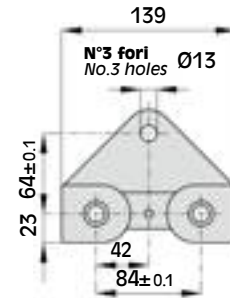

Vista base di montaggio  
View on caliper base

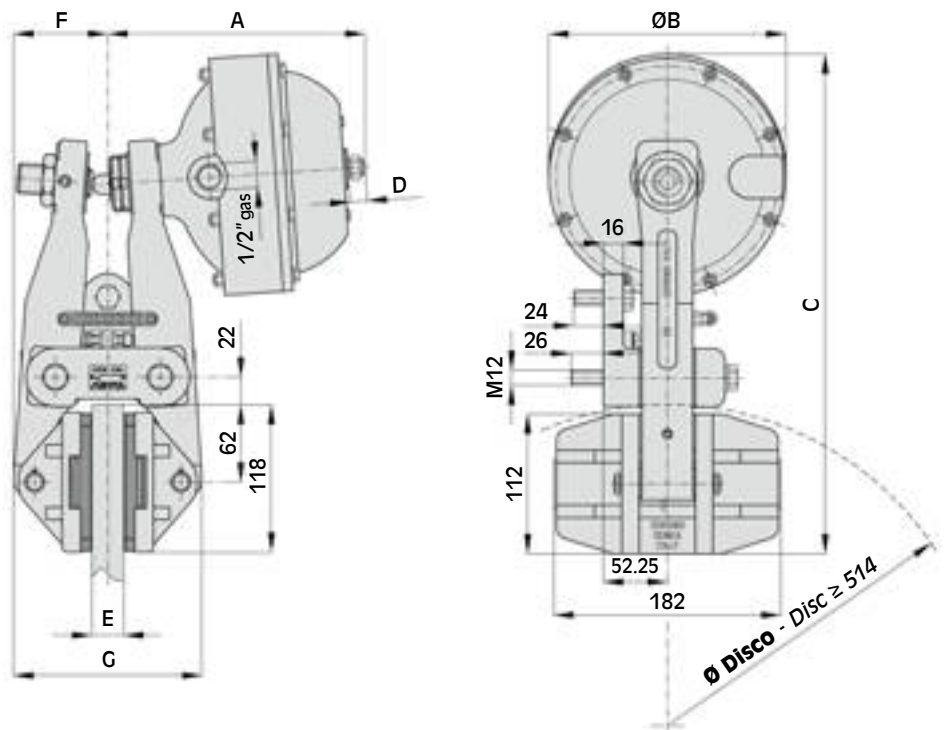

## DIMENSIONI/DIMENSIONS



TIPO SIZE	Cod. Prodotto Product Number	A	ØB	C	D	E	F	G	Volume aria Air Volume dm <sup>3</sup>	Peso Weight kg
G-2N	A2161	178	144	375	14	25.4	75.5	151	0.3	18.2
	A2862	186	144	375	14	40	86	165.5	0.3	18.2
G-3N	A2164	206	190	399	14	25.4	75.5	151	0.7	21.3
	A2866	214	190	399	14	40	86	165.5	0.7	21.3
G-3.5N	A2167	222	240	426	16	25.4	75.5	151	0.95	25.7
	A2870	230	240	426	16	40	86	165.5	0.95	25.7

**Attenzione:** La coppia iniziale può essere dal 30% al 50% in meno rispetto al valore nominale, fino all'assestamento del ferodo sul disco.

**Warning:** The initial torque on new units can be 30% to 50% less than the catalogue value until the friction facing and friction disc are lapped or worn in.

## Dati tecnici

Forza tangenziale F:

G-2N	5250 N
G-3N	10400 N
G-3.5N	19260 N

Coppia dinamica  
 $= F \cdot (\text{raggio del disco in m} - 0.062) = \text{Nm}$

Usura max totale: 10 mm

Spessore del ferodo nuovo: 8 mm

Dissipazione del calore in continuo  
 Qc: 14 kW

Pressione minima di apertura: 5 bar

I valori di coppia indicati sono ottenuti con:  
 n. 8 molle per 2N-3N,  
 n. 12 molle per 3.5N.

Copie proporzionalmente inferiori si possono ottenere con:  
 n. 6-4-2 molle per 2N-3N,  
 n. 10-8-6 molle per 3.5N.

Il grafico rappresenta l'andamento della coppia per ogni millimetro di usura dei ferodi.

Per ripristinare il valore nominale della coppia intervenire sul sistema di regolazione.

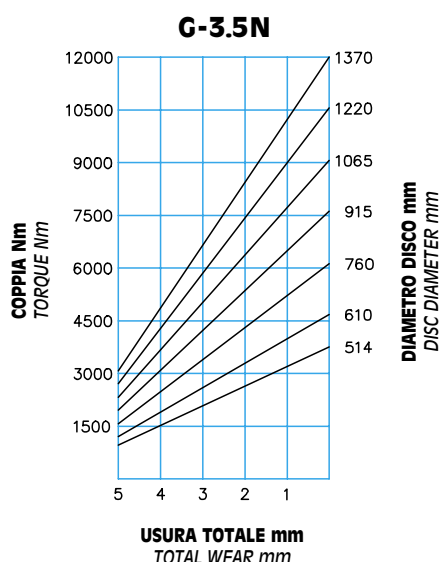
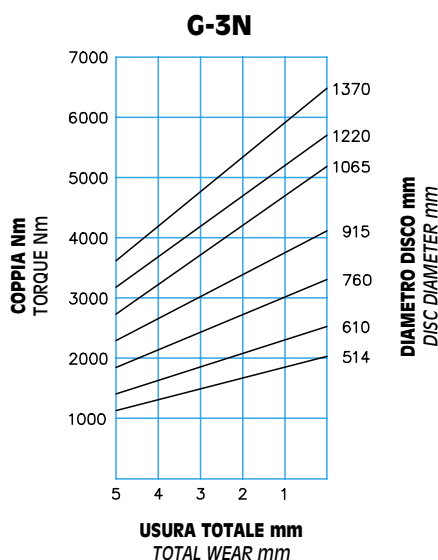
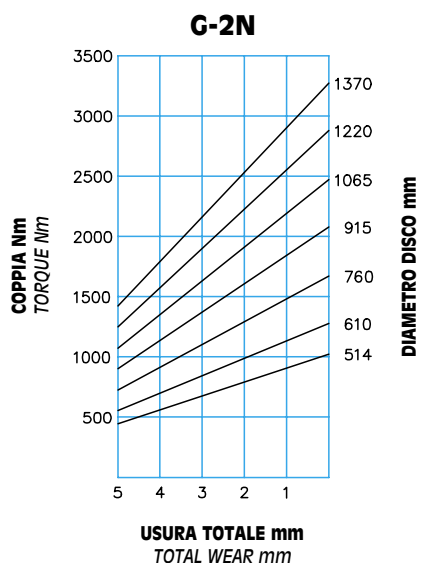

## Technical data

Braking force F:

G-2N	5250 N
G-3N	10400 N
G-3.5N	19260 N

Dynamic torque  
 $= F \cdot (\text{disc radius in m} - 0.062) = \text{Nm}$

Max total wear: 10 mm

Thickness of new lining: 8 mm

Continuous thermal capacity  
 Qc: 14 kW

Minimum release pressure: 5 bar

The torque values specified are obtained with

No. 8 springs for 2N-3N,  
 No. 12 springs for 3.5N.

Torque proportionally less are achievable with

No. 6-4-2 springs for 2N-3N,  
 No. 10-8-6 springs for 3.5N.

The diagram shows the torque variation for each millimeter of linings wear.

Adjust according to ensure the correct torque value is achieved.

## DIAGRAMMA/CHART

### Dissipazione di calore per frenatura di emergenza

Thermal capacity for emergency stop

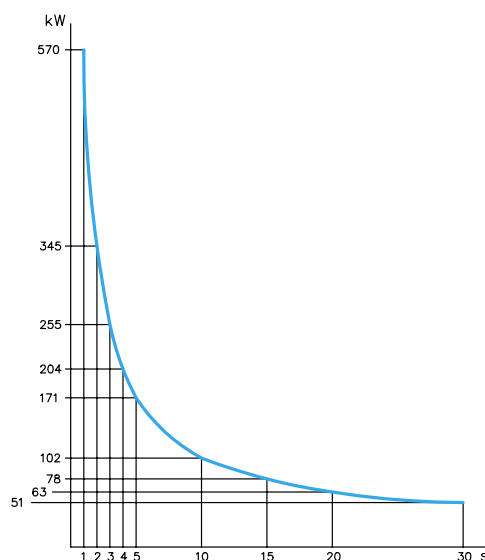



# COMBINATI Positivi / Negativi "Dual"



# COMBINED Air Applied / Failsafe "Dual"

**Le tipiche funzioni positiva e negativa sono ora anche combinate in un unico pistone pneumatico per applicazioni industriali dove sia richiesto tensionamento o frenatura controllata così come frenatura di emergenza. La possibilità di montare un unico freno anziché due comporta evidenti vantaggi di spazio e di costo.**

*Air applied and spring applied functions in one single pneumatic thruster to match both tensioning or controlled braking applications as well as emergency stopping with one single caliper brake.*

*Main advantages include cost saving and space saving for the industrial machine where the brake is installed.*



# A-Dual

**Disponibile anche per disco spessore 25,4 mm.**  
*Available also for disc thickness 25,4 mm.*



**Versione pattino doppio**  
*Duble pad version*

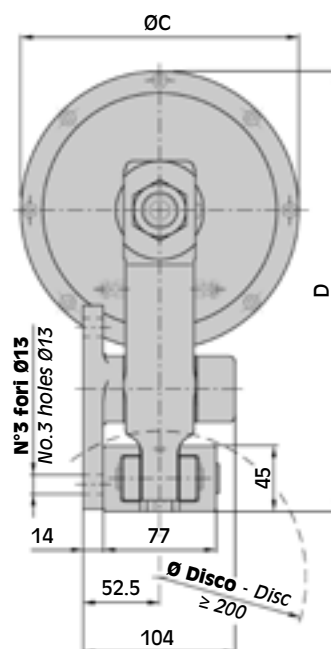
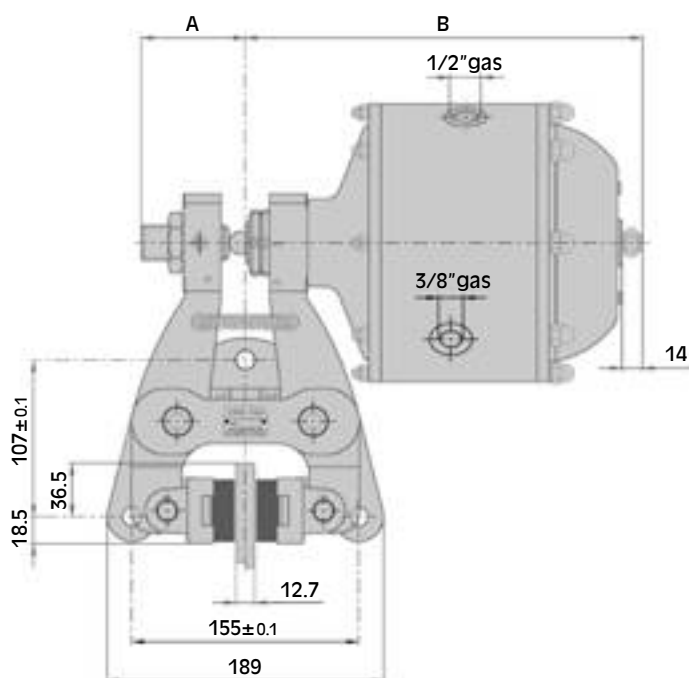
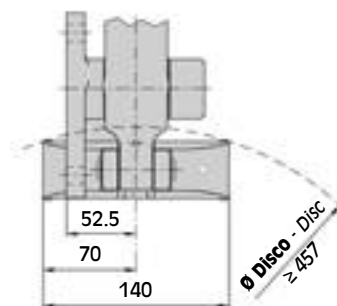

## DIMENSIONI/DIMENSIONS



TIPO SIZE	Cod. Prodotto Product Number		A	B	ØC	D	Volume aria Air Volume dm <sup>3</sup>		Peso Weight kg
	S.P.	S.U.					Positivo Air actuated	Negativo Spring applied	
A1-2N	A3322	A3324	72	242.5	144	277.5	0.12	0.22	16.5
A3-3N	A3330	A3332	71	271.5	190	300.5	0.26	0.4	22
<p><b>S.P. = Produzione Standard / Standard Production</b>  <b>S.U. = Con segnalatore di usura / With Wear Indicator</b></p>									

**Attenzione:** La coppia iniziale può essere dal 30% al 50% in meno rispetto al valore nominale, fino all'assestamento del ferodo sul disco.

**Warning:** The initial torque on new units can be 30% to 50% less than the catalogue value until the friction facing and friction disc are lapped or worn in.

## A3-3N Dual

**Positivo - 3**  
Air applied - 3

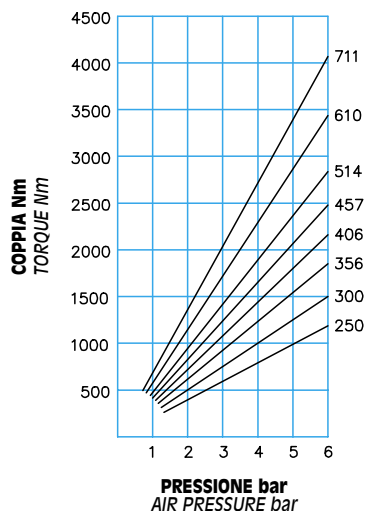

**Negativo - 3N**  
Spring applied - 3N

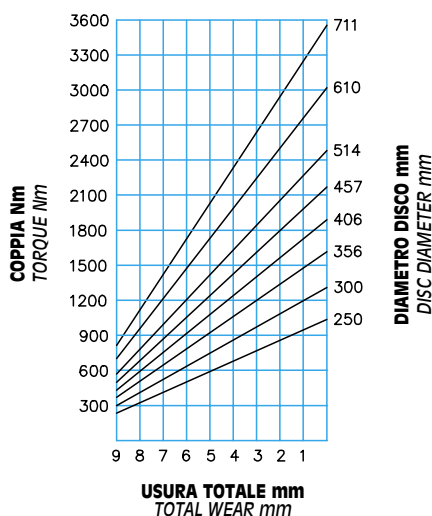

## A1-2N Dual

**Positivo - 1**  
Air applied - 1

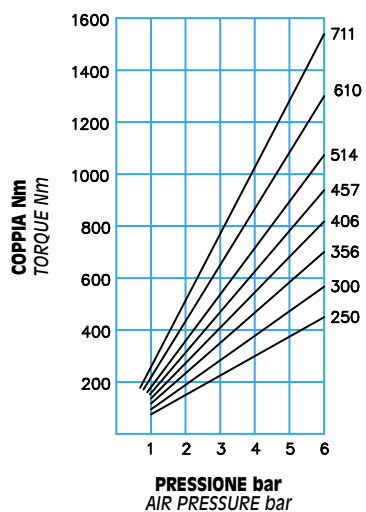

**Negativo - 2N**  
Spring applied - 2N

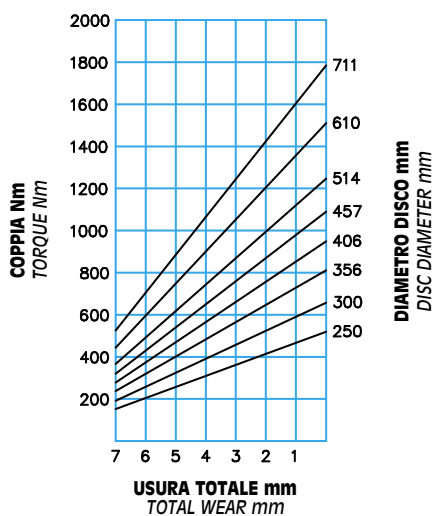

## Dati tecnici

Forza tangenziale F:

**A3-3N** positivo 12490 N a 6 bar  
negativo 10970 N

**A1-2N** positivo 4820 N a 6 bar  
negativo 5500 N

Coppia dinamica  
=  $F \cdot (\text{raggio del disco in m} - 0.03) = \text{Nm}$

Usura max totale: 16 mm

Spessore del ferodo nuovo: 16 mm

Dissipazione del calore in continuo  
Qc: 1.7 kW

Dissipazione di calore in continuo  
con pattino doppio Qc: 2.7 kW

Pressione minima di apertura  
(negativo): 5 bar

I valori di coppia indicati per il freno,  
quando negativo, sono ottenuti con  
n. 8 molle.

Coppie proporzionalmente inferiori si  
possono ottenere con n. 6-4-2 molle.  
Il grafico rappresenta l'andamento  
della coppia per ogni millimetro  
di usura dei ferodi.

Per ripristinare il valore nominale  
della coppia intervenire sul sistema  
di regolazione.

## Technical data

Braking force F:

**A3-3N** air actuated 12490 N at 6 bar  
spring applied 10970 N

**A1-2N** air actuated 4820 N at 6 bar  
spring applied 5500 N

Dynamic torque  
=  $F \cdot (\text{disc radius in m} - 0.03) = \text{Nm}$

Max total wear: 16 mm

Thickness of new lining: 16 mm

Continuous thermal capacity  
Qc: 1.7 kW

Continuous thermal capacity  
for double pad version Qc: 2.7 kW

Minimum release pressure  
(spring applied): 5 bar

The torque values specified,  
when the brake is spring applied,  
are obtained with n. 8 springs.  
Torque proportionally less  
are achievable with n. 6-4-2 springs.  
The diagram shows the torque  
variation for each millimeter  
of lining wear.

Adjust according to ensure the  
correct torque value is achieved.

## DIAGRAMMA/CHART

### Dissipazione di calore per frenatura di emergenza

Thermal capacity for emergency stop

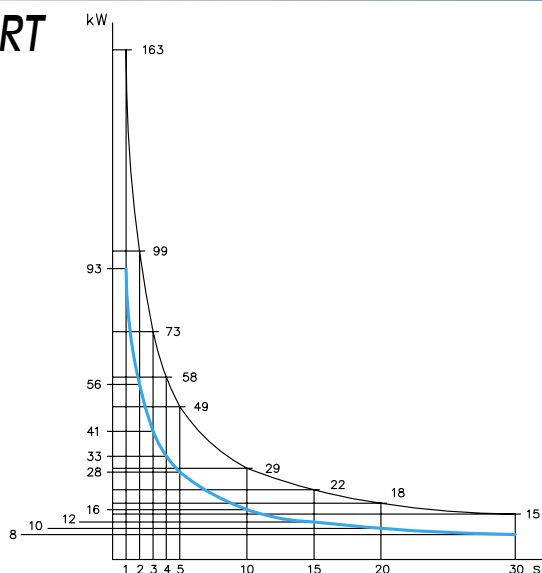

Pattino doppio Double pad  
Pattino standard Standard pad

# D-Dual

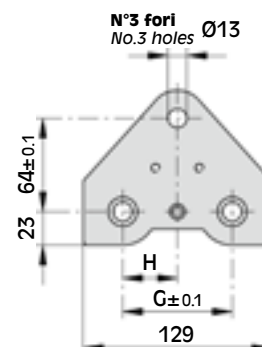

Vista base di montaggio  
View on caliper base

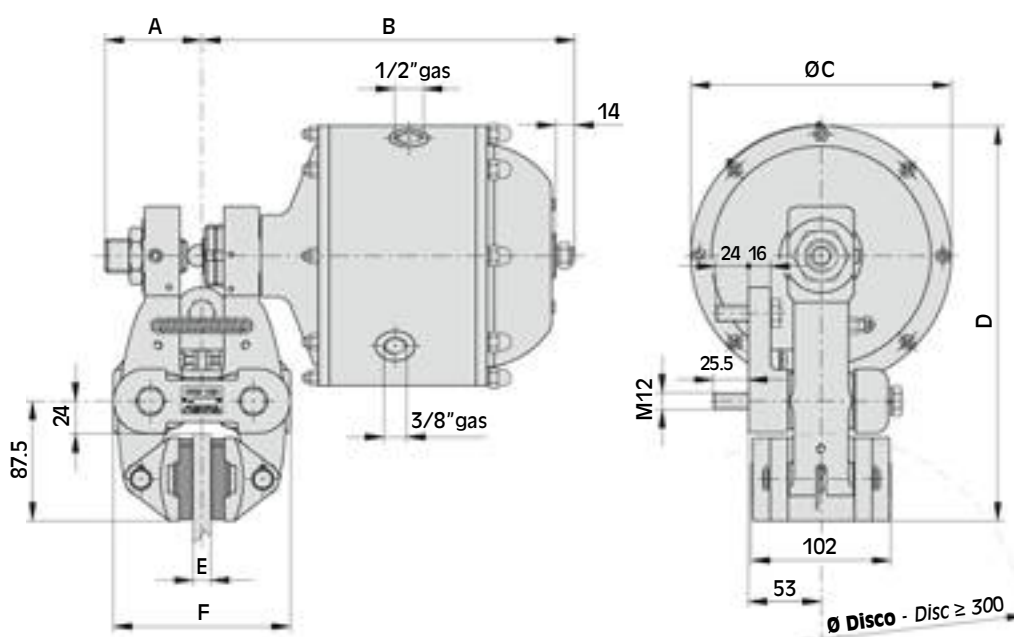

## DIMENSIONI/DIMENSIONS



TIPO SIZE	Cod. Prodotto Product Number	A	B	ØC	D	E	F	G	H	Volume aria Air Volume dm <sup>3</sup>		Peso Weight kg
										Positivo Air actuated	Negativo Spring applied	
D1-2N	A3094	72	242	144	265.5	12.7	129	75	37.5	0.12	0.22	15.1
	A3079	71	243	144	270	25.4	132	84	42	0.12	0.22	15.1
	A3111	83	251	144	265.5	30	140	75	37.5	0.12	0.22	15.1
	A3119	79	256	144	265.5	40	149	84	42	0.12	0.22	15.1
D3-3N	A2718	70.5	272	190	288.5	12.7	129	75	37.5	0.26	0.4	20.6
	A2726	70	272.5	190	289	25.4	132	84	42	0.26	0.4	20.6
	A2734	81.5	281	190	288.5	30	140	75	37.5	0.26	0.4	20.6
	A2742	77	285.5	190	288.5	40	149	84	42	0.26	0.4	20.6

**Attenzione:** La coppia iniziale può essere dal 30% al 50% in meno rispetto al valore nominale, fino all'assestamento del ferodo sul disco.

**Warning:** The initial torque on new units can be 30% to 50% less than the catalogue value until the friction facing and friction disc are lapped or worn in.

## D3-3N Dual

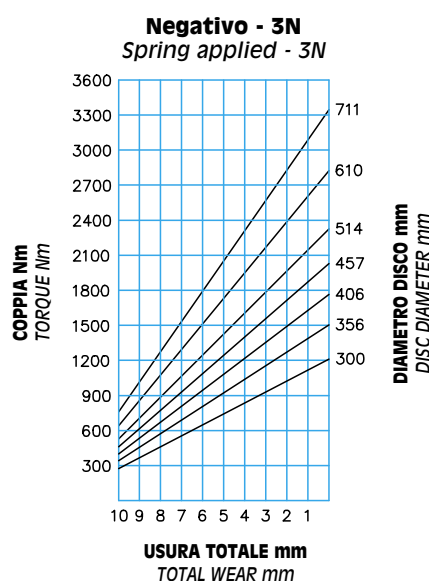
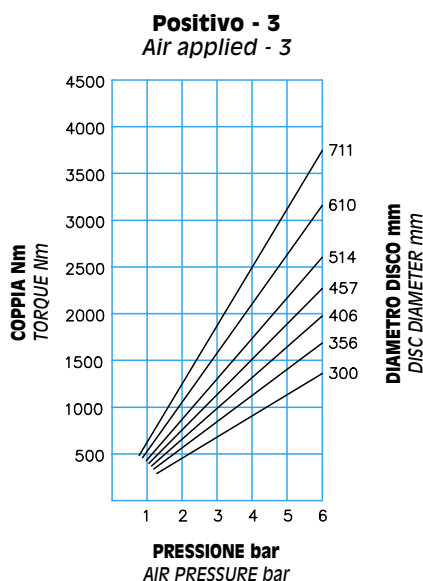

## D1-2N Dual

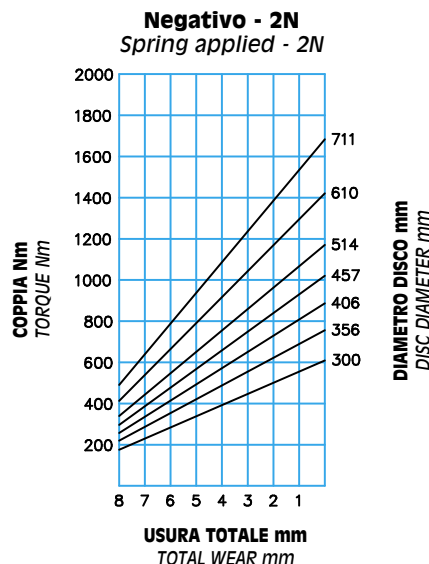
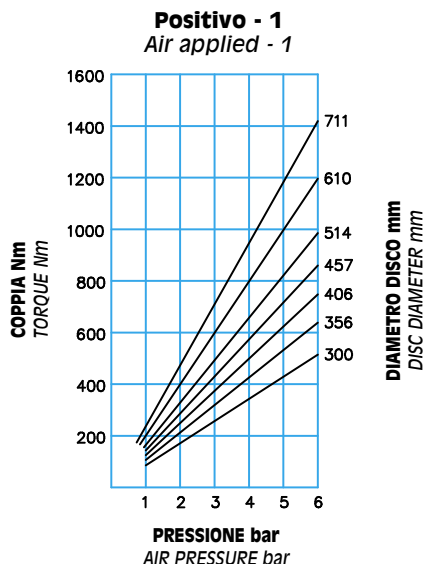

## DIAGRAMMA/CHART

### Dissipazione di calore per frenatura di emergenza

Thermal capacity for emergency stop

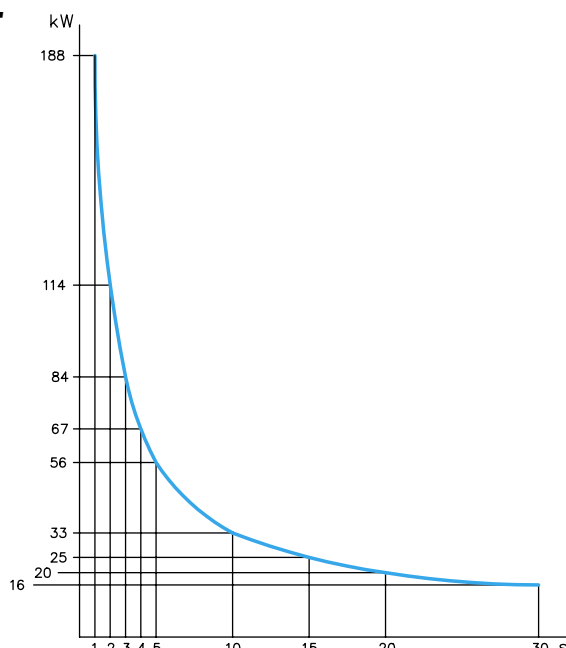

## Dati tecnici

Forza tangenziale F:

**D3-3N** positivo 11620 N a 6 bar  
negativo 10400 N

**D1-2N** positivo 4480 N a 6 bar  
negativo 5250 N

Coppia dinamica  
=  $F \cdot (\text{raggio del disco in m} - 0.033) = \text{Nm}$

Usura max totale: 12 mm

Spessore del ferodo nuovo: 11 mm

Dissipazione del calore in continuo  
QC: 3.4 kW

Pressione minima di apertura  
(negativo): 5 bar

I valori di coppia indicati per il freno, quando negativo, sono ottenuti con n. 8 molle. Coppie proporzionalmente inferiori si possono ottenere con n. 6-4-2 molle.

Il grafico rappresenta l'andamento della coppia per ogni millimetro di usura dei ferodi.

Per ripristinare il valore nominale della coppia intervenire sul sistema di regolazione.

## Technical data

Braking force F:

**D3-3N** air actuated 11620 N at 6 bar  
spring applied 10400 N

**D1-2N** air actuated 4480 N at 6 bar  
spring applied 5250 N

Dynamic torque

=  $F \cdot (\text{disc radius in m} - 0.033) = \text{Nm}$

Max total wear: 12 mm

Thickness of new lining: 11 mm

Continuous thermal capacity  
QC: 3.4 kW

Minimum release pressure  
(spring applied): 5 bar

The torque values specified, when the brake is spring applied, are obtained with n. 8 springs. Torque proportionally less are achievable with n. 6-4-2 springs. The diagram shows the torque variation for each millimeter of lining wear.

Adjust according to ensure the correct torque value is achieved.

## F-Dual

**Disponibile anche per disco spessore 25,4 - 30 - 40 mm.**  
*Available also for disc thickness 25,4 - 30 - 40 mm.*

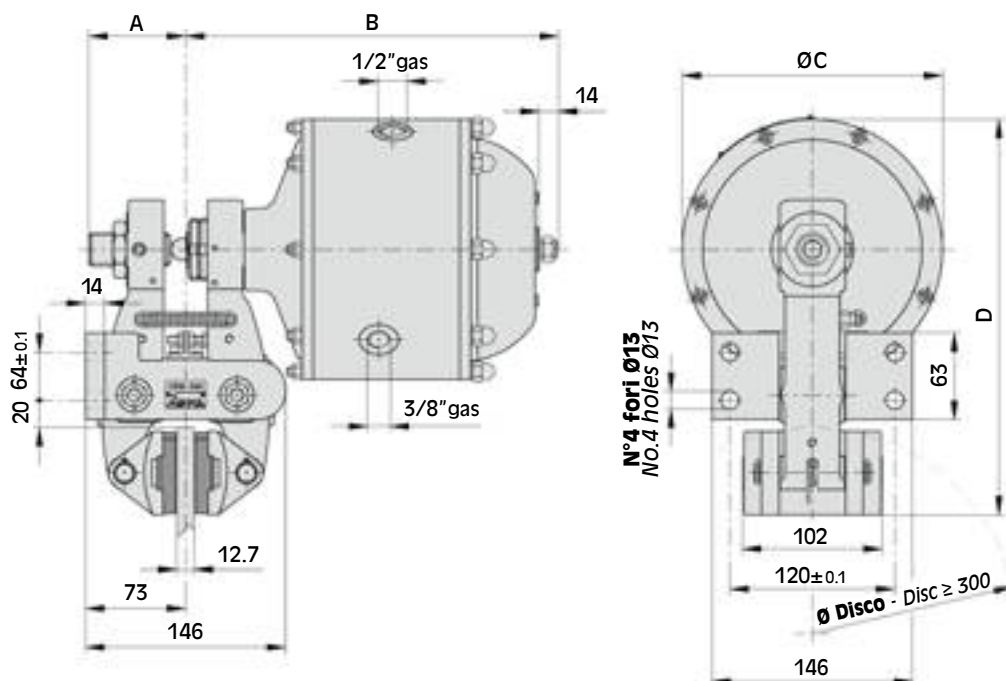

### DIMENSIONI/DIMENSIONS



TIPO SIZE	Cod. Prodotto Product Number	A	B	ØC	D	Volume aria air Volume dm <sup>3</sup>		Peso Weight kg
						Positivo Air actuated	Negativo Spring applied	
F1-2N	A3127	72	242	144	265.5	0.12	0.22	14.8
F3-3N	A2838	70.5	272	190	288.5	0.26	0.4	20.3

**Attenzione:** La coppia iniziale può essere dal 30% al 50% in meno rispetto al valore nominale, fino all'assestamento del ferodo sul disco.

**Warning:** The initial torque on new units can be 30% to 50% less than the catalogue value until the friction facing and friction disc are lapped or worn in.

## F3-3N Dual

**Positivo - 3**  
Air applied - 3

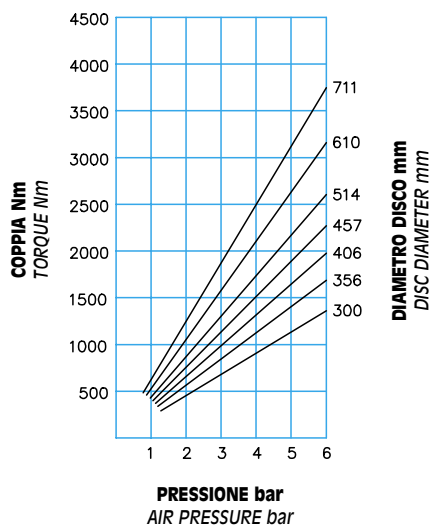

**Negativo - 3N**  
Spring applied - 3N

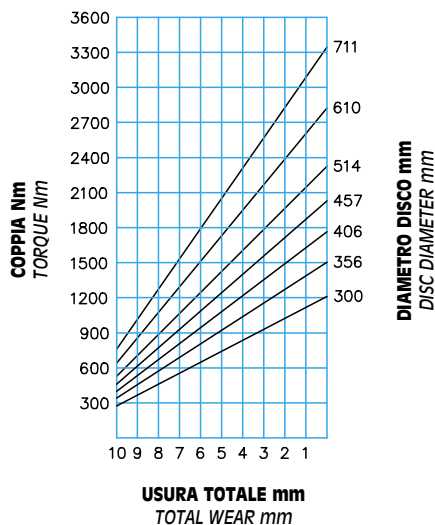

## F1-2N Dual

**Positivo - 1**  
Air applied - 1

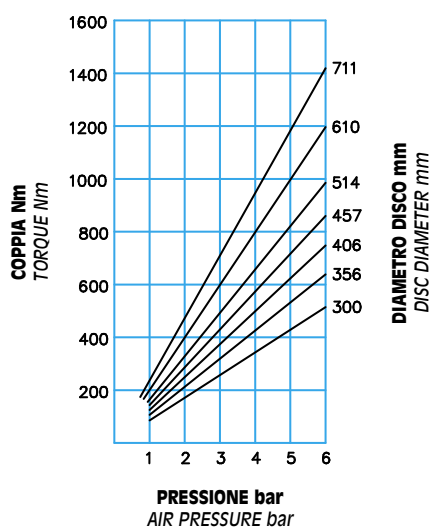

**Negativo - 2N**  
Spring applied - 2N

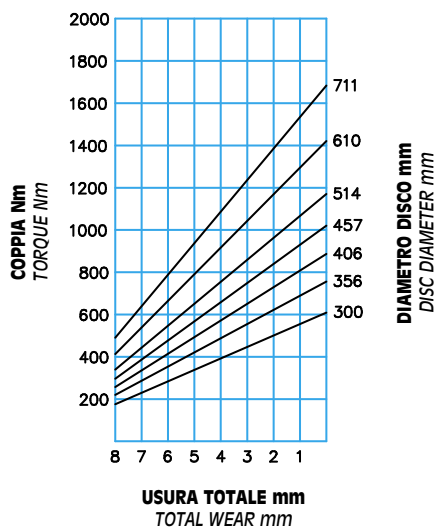

## DIAGRAMMA/CHART

### Dissipazione di calore per frenatura di emergenza

Thermal capacity for emergency stop

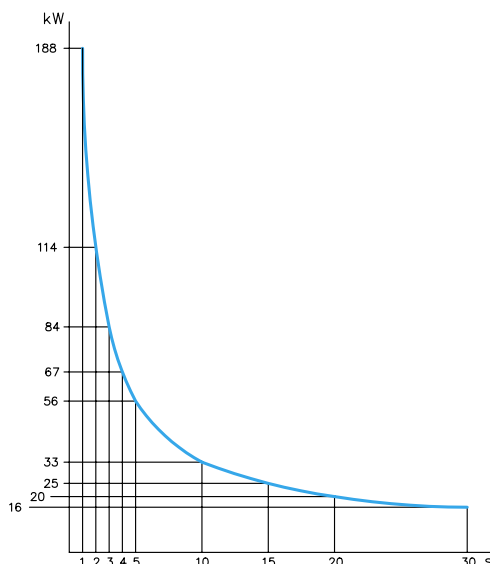

## Dati tecnici

Forza tangenziale F:

**F3-3N** positivo 11620 N a 6 bar  
negativo 10400 N

**F1-2N** positivo 4480 N a 6 bar  
negativo 5250 N

Coppia dinamica  
=  $F \cdot (\text{raggio del disco in m} - 0.033) = \text{Nm}$

Usura max totale: 12 mm

Spessore del ferodo nuovo: 11 mm

Dissipazione del calore in continuo  
Qc: 3.4 kW

Pressione minima di apertura  
(negativo): 5 bar

I valori di coppia indicati per il freno, quando negativo, sono ottenuti con n. 8 molle. Coppie proporzionalmente inferiori si possono ottenere con n. 6-4-2 molle.

Il grafico rappresenta l'andamento della coppia per ogni millimetro di usura dei ferodi.

Per ripristinare il valore nominale della coppia intervenire sul sistema di regolazione.

## Technical data

Braking force F:

**F3-3N** air actuated 11620 N at 6 bar  
spring applied 10400 N

**F1-2N** air actuated 4480 N at 6 bar  
spring applied 5250 N

Dynamic torque

=  $F \cdot (\text{disc radius in m} - 0.033) = \text{Nm}$

Max total wear: 12 mm

Thickness of new lining: 11 mm

Continuous thermal capacity  
Qc: 3.4 kW

Minimum release pressure  
(spring applied): 5 bar

The torque values specified, when the brake is spring applied, are obtained with n. 8 springs. Torque proportionally less are achievable with n. 6-4-2 springs.

The diagram shows the torque variation for each millimeter of lining wear.

Adjust according to ensure the correct torque value is achieved.

# G-Dual

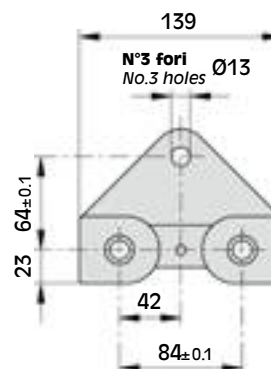

Vista base di montaggio  
View on caliper base

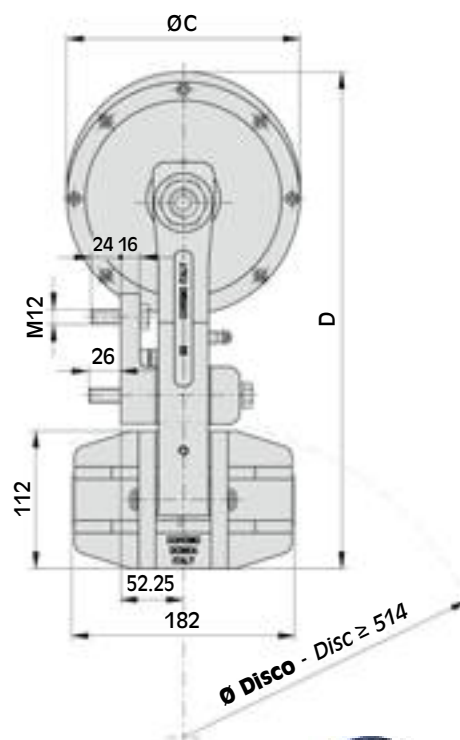
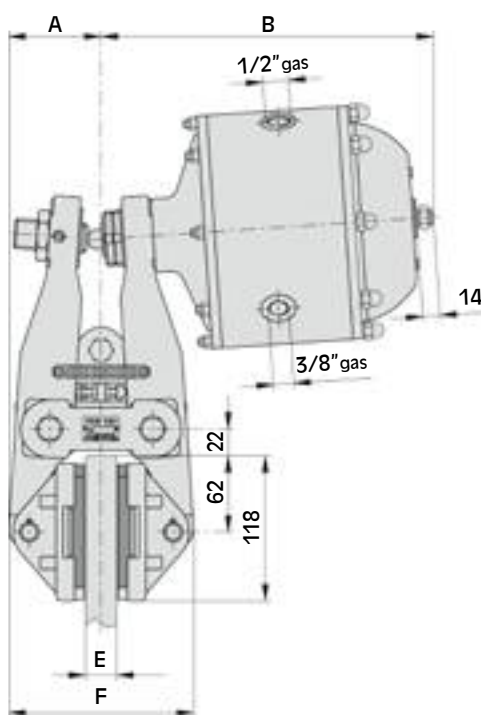

## DIMENSIONI/DIMENSIONS



TIPO SIZE	Cod. Prodotto Product Number	A	B	ØC	D	E	F	Volume aria Air Volume dm <sup>3</sup>		Peso Weight kg
								Positivo Air actuated	Negativo Spring applied	
G1-2N	A3135	75.5	241	144	380	25.4	151	0.12	0.22	21
	A3139	85	249	144	380	40	165.5	0.12	0.22	21
G3-3N	A2898	75.5	271	190	405	25.4	151	0.26	0.4	26.5
	A2902	84	279	190	405	40	165.5	0.26	0.4	26.5

**Attenzione:** La coppia iniziale può essere dal 30% al 50% in meno rispetto al valore nominale, fino all'assestamento del ferodo sul disco.

**Warning:** The initial torque on new units can be 30% to 50% less than the catalogue value until the friction facing and friction disc are lapped or worn in.

## G3-3N Dual

**Positivo - 3**  
Air applied - 3

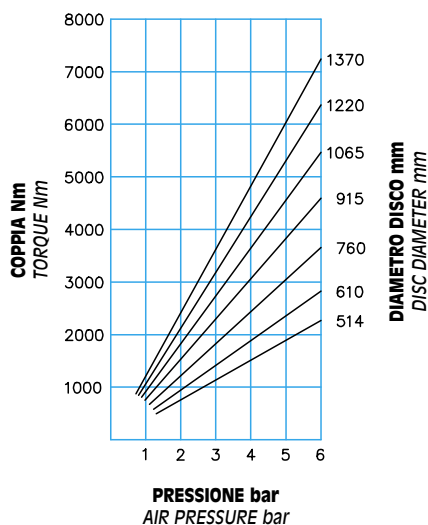

**Negativo - 3N**  
Spring applied - 3N

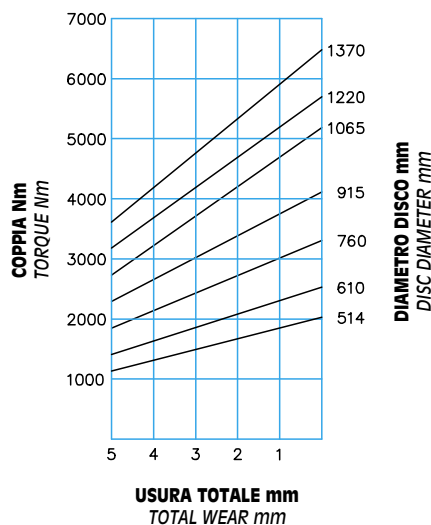

## G1-2N Dual

**Positivo - 1**  
Air applied - 1

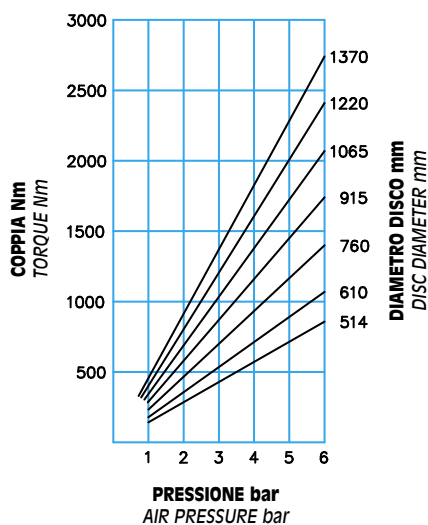

**Negativo - 2N**  
Spring applied - 2N

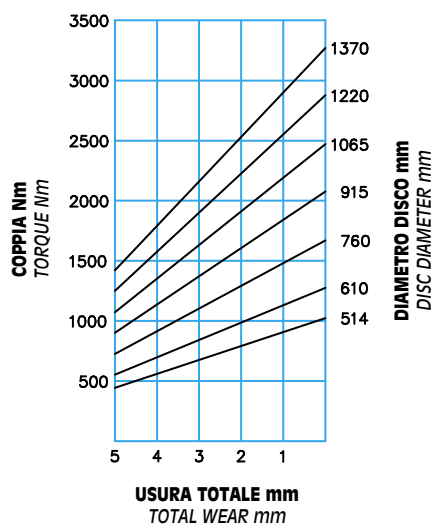

## DIAGRAMMA/CHART

### Dissipazione di calore per frenatura di emergenza

Thermal capacity for emergency stop

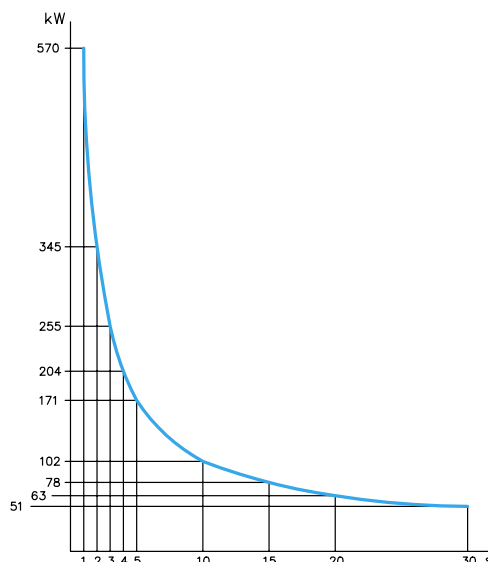

## Dati tecnici

Forza tangenziale F:

**G3-3N** positivo 11620 N a 6 bar  
negativo 10400 N

**G1-2N** positivo 4460 N a 6 bar  
negativo 5250 N

Coppia dinamica  
=  $F \cdot (\text{raggio del disco in m} - 0.062) = \text{Nm}$

Usura max totale: 10 mm

Spessore del ferodo nuovo: 8 mm

Dissipazione del calore in continuo  
QC: 14 kW

Pressione minima di apertura  
(negativo): 5 bar

I valori di coppia indicati per il freno, quando negativo, sono ottenuti con n. 8 molle. Coppie proporzionalmente inferiori si possono ottenere con n. 6-4-2 molle.

Il grafico rappresenta l'andamento della coppia per ogni millimetro di usura dei ferodi.

Per ripristinare il valore nominale della coppia intervenire sul sistema di regolazione.

## Technical data

Braking force F:

**G3-3N** air actuated 11620 N at 6 bar  
spring applied 10400 N

**G1-2N** air actuated 4460 N at 6 bar  
spring applied 5250 N

Dynamic torque

=  $F \cdot (\text{disc radius in m} - 0.062) = \text{Nm}$

Max total wear: 10 mm

Thickness of new lining: 8 mm

Continuous thermal capacity  
QC: 14 kW

Minimum release pressure  
(spring applied): 5 bar

The torque values specified, when the brake is spring applied, are obtained with n. 8 springs. Torque proportionally less are achievable with n. 6-4-2 springs. The diagram shows the torque variation for each millimeter of lining wear.

Adjust according to ensure the correct torque value is achieved.

La necessità di offrire ai clienti soluzioni al passo con i tempi, ci ha portato a migliorare il prodotto introducendo novità che possono risolvere le esigenze delle macchine moderne. E' quindi disponibile una ricca serie di accessori, di cui alcuni nella dotazione standard, per tutta la gamma dei freni a pinza.

Our goal is to offer an up-to-date product to our customers and this has forced us to improve quality product introducing new features which could solve modern machine requirements. So, it is available a wide devices range, some of them on standard providing, for all caliper brakes range.

1	RECUPERO USURA FERODI	WEAR COMPENSATION
2	BILANCIAMENTO	INCLINED MOUNTING KIT
3	ALLINEAMENTO PATTINI	PADS SELF ALIGNMENT
4	SEGNALATORE USURA	WEAR INDICATOR
5	PATTINO DOPPIO	DOUBLE PADS
6	INDICATORE APERTO-CHIUSO	ON-OFF INDICATOR
7	VITE DI RITEGNO	RETAINING SCREW
8	NUMERO DI SERIE	SERIAL NUMBER



## Dispositivi e caratteristiche dei freni Caliper brakes features and devices

	MPA	A	B	C	D	E EL	F	G	MPA-N	A-N	B-N	D-N	E-N EL-N	F-N	G-N
<b>RECUPERO USURA FERODI</b> WEAR COMPENSATION	-	●	-	●	●	●	●	●	●	●	●	●	●	●	●
<b>BILANCIAMENTO</b> INCLINED MOUNTING KIT	○	●	○	●	●	●	●	●	○	●	○	●	●	●	●
<b>ALLINEAMENTO PATTINI</b> PADS SELF ALIGNMENT	●	●	●	●	●	●	●	●	●	●	●	●	●	●	●
<b>SEGNALATORE USURA</b> WEAR INDICATOR	-	○	○	-	○	○	○	○	-	○	○	○	○	○	○
<b>PATTINO DOPPIO</b> DOUBLE PADS	-	○	○	-	-	-	-	-	-	○	○	-	-	-	-
<b>INDICATORE APERTO-CHIUSO</b> ON-OFF INDICATOR	-	○	○	-	○	○	○	○	-	○	○	○	○	○	○
<b>VITE DI RITEGNO</b> RETAINING SCREW	-	-	-	-	-	-	-	-	-	●	●	●	●	●	●
<b>N° DI SERIE</b> SERIAL NUMBER	●	●	●	●	●	●	●	●	●	●	●	●	●	●	●

**Nota:** ● = di serie      ○ = Opzionale      - = Non applicabile  
**Note:** ● = Standard      ○ = Optional      - = Not available

**1**

**RECUPERO USURA FERODI**

*WEAR COMPENSATION*

**Prestazioni ottimali con il ripristino del gioco**

*First rate performance with wear compensation*

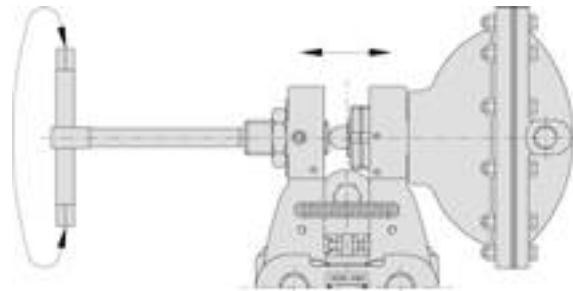

**2**

**BILANCIAMENTO**

*INCLINED MOUNTING KIT*

**Si può montare il freno in ogni posizione**

*You can mount brake in any position*

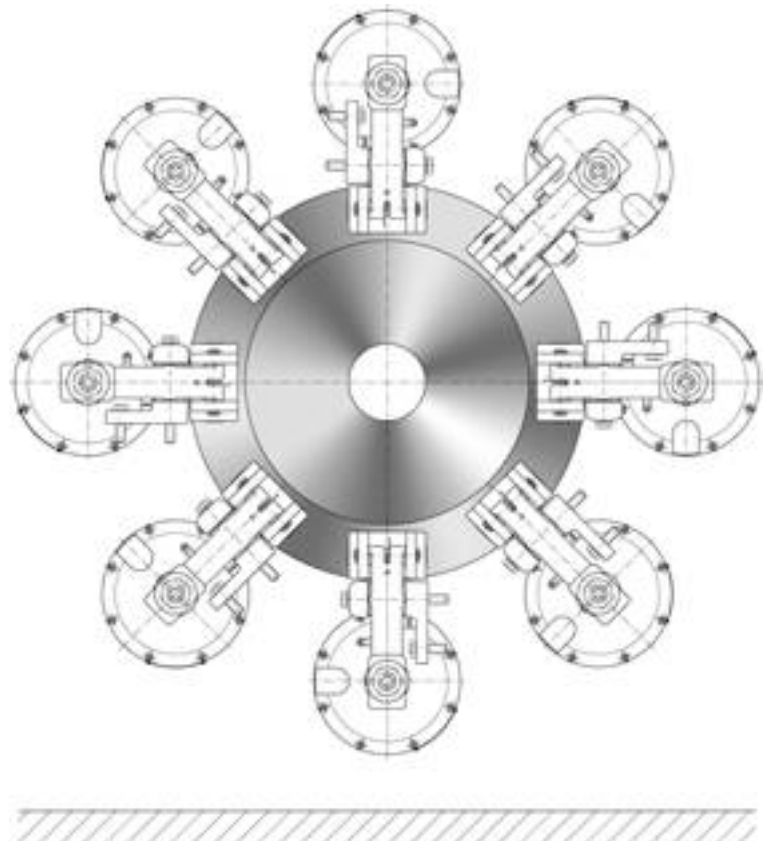

3

**ALLINEAMENTO PATTINI**

*PADS SELF ALIGNMENT*

## **Parallelismo tra ferodo e disco**

*Lining regular wear granted by pads self-alignment*

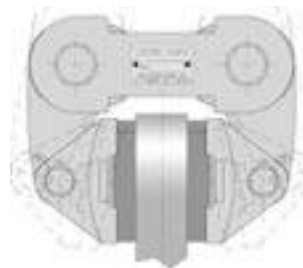

4

**SEGNALATORE USURA**

*WEAR INDICATOR*

## **Evitate le soste e guasti utilizzando l'indicatore di usura**

*It is possible to avoid break-down and failure using wear indicator*

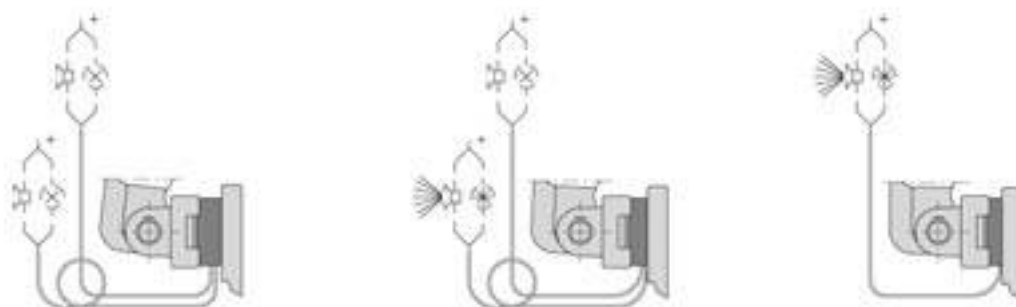

5

**PATTINO DOPPIO**

*DOUBLE PADS*

## **Maggiore dissipazione e minore usura raddoppiando l'area del ferodo**

*More heat dissipation and less lining wear with doubled linings area*

**Versione standard**  
*Standard version*

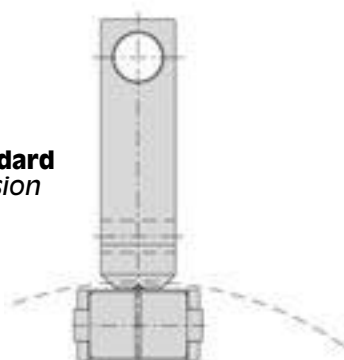

**Versione con pattino doppio**  
*Double pad version*

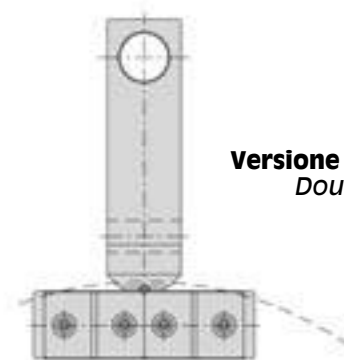

**6**

**INDICATORE APERTO-CHIUSO**

*ON-OFF INDICATOR*

**Evitate partenze a freno chiuso**

*Before starting the machine, check if brake is open*

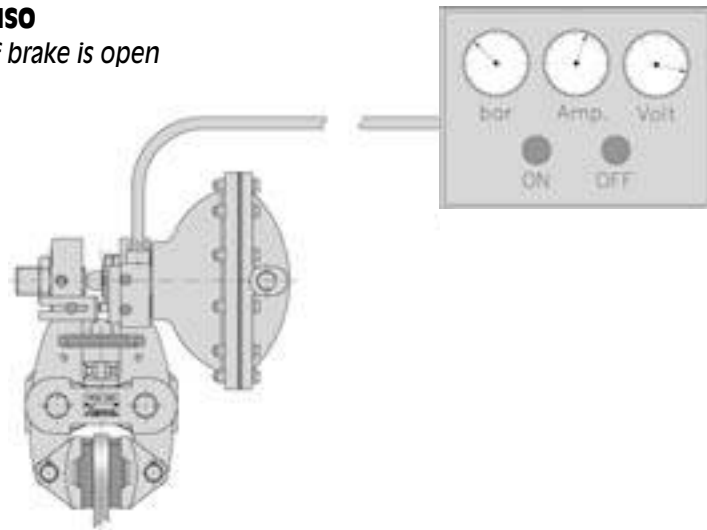

**7**

**VITE DI RITEGNO**

*RETAINING SCREW*

**Garantisce la sicurezza in fase di montaggio**

*Safety during mounting operation*

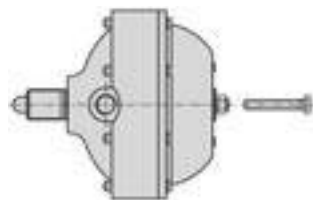

**Freno in funzione**  
*Brake on use*

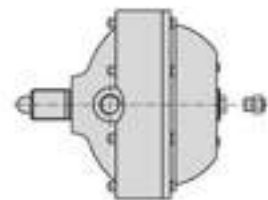

**Freno in fase di montaggio e manutenzione**  
*Brake during mounting and maintenance*

**8**

**NUMERO DI SERIE**

*SERIAL NUMBER*

**Indicate il numero di serie per ordinare i ricambi**

*To order spare parts, indicate serial number*

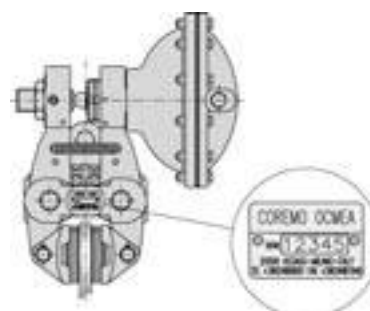



...RICHIEDETE L'ELENCO  
DEI NOSTRI AGENTI  
E DISTRIBUTORI

...FULL LIST OF OUR  
AGENTS/REPRESENTATIVES  
IS AVAILABLE ON REQUEST

# Network



*Noi siamo qui*

*We are here*

- |   |  |  |  |
|---|--|--|--|
| <ul style="list-style-type: none"> <li>• ARGENTINA</li> <li>• AUSTRALIA</li> <li>• AUSTRIA</li> <li>• BELGIO</li> <li>• BRASILE</li> <li>• CANADA</li> <li>• CINA</li> <li>• COREA</li> <li>• DANIMARCA</li> <li>• EGITTO</li> <li>• FILIPPINE</li> <li>• FINLANDIA</li> <li>• FRANCIA</li> <li>• GERMANIA</li> <li>• GHANA</li> <li>• GIAPPONE</li> <li>• GRECIA</li> <li>• INDIA</li> <li>• INDONESIA</li> <li>• ISRAELE</li> <li>• ITALIA</li> </ul> | <ul style="list-style-type: none"> <li>• LUSSEMBURGO</li> <li>• MALESIA</li> <li>• MESSICO</li> <li>• NORVEGIA</li> <li>• NUOVA ZELANDA</li> <li>• PAESI BASSI</li> <li>• POLONIA</li> <li>• PORTOGALLO</li> <li>• REGNO UNITO</li> <li>• REP. CECA</li> <li>• RUSSIA</li> <li>• SINGAPORE</li> <li>• SLOVACCHIA</li> <li>• SPAGNA</li> <li>• SUD AFRICA</li> <li>• SVEZIA</li> <li>• SVIZZERA</li> <li>• TAILANDIA</li> <li>• TAIWAN</li> <li>• TURCHIA</li> <li>• USA</li> </ul> | <ul style="list-style-type: none"> <li>• ARGENTINA</li> <li>• AUSTRALIA</li> <li>• AUSTRIA</li> <li>• BELGIUM</li> <li>• BRAZIL</li> <li>• CANADA</li> <li>• CHINA</li> <li>• CZECH REP.</li> <li>• DENMARK</li> <li>• EGYPT</li> <li>• FINLAND</li> <li>• FRANCE</li> <li>• GERMANY</li> <li>• GHANA</li> <li>• GREECE</li> <li>• INDIA</li> <li>• INDONESIA</li> <li>• ISRAEL</li> <li>• ITALY</li> <li>• JAPAN</li> <li>• LUXEMBOURG</li> </ul> | <ul style="list-style-type: none"> <li>• KOREA</li> <li>• MALAYSIA</li> <li>• MEXICO</li> <li>• NEW ZEALAND</li> <li>• NORWAY</li> <li>• PHILIPPINES</li> <li>• POLAND</li> <li>• PORTUGAL</li> <li>• RUSSIA</li> <li>• SINGAPORE</li> <li>• SLOVAKIA</li> <li>• SOUTH AFRICA</li> <li>• SPAIN</li> <li>• SWEDEN</li> <li>• SWITZERLAND</li> <li>• TAIWAN</li> <li>• THAILAND</li> <li>• THE NETHERLANDS</li> <li>• TURKEY</li> <li>• UK</li> <li>• USA</li> </ul> |
|---|--|--|--|

Welcome to  
**COREMO**



Richiedete i  
nostri cataloghi

For Catalogues, contact us



[www.coremo.it](http://www.coremo.it)  
[coremo@ocmea.it](mailto:coremo@ocmea.it)

I.T. 070618

---

**DISTRIBUITO DA**

*DISTRIBUTED BY*

**Distribuidor Autorizado e Importador**

**Arten Freios e Embreagens Ltda**

**Fone: (11) 5594-8333 • Fax (11) 5589-2422**

**E-mail: [arten@arten.com.br](mailto:arten@arten.com.br) • Site: [www.arten.com.br](http://www.arten.com.br)**



**FRENI  
FRIZIONI PNEUMATICHE  
GIUNTI  
CONTROLLI INDUSTRIALI**

*BRAKES  
PNEUMATIC CLUTCHES  
COUPLINGS  
INDUSTRIAL CONTROLS*

SEDE CENTRALE E STABILIMENTO  
*HEAD OFFICE AND WORKS*

**COREMO OCMEA S.P.A.**

20090 Assago (MI) - ITALY  
via Galilei, 12  
p.o. box 8 Assago  
tel. +39 02 48 80 697 (5 linee r.a.)  
fax +39 02 48 81 940  
internet: [www.coremo.it](http://www.coremo.it)  
e-mail: [coremo@ocmea.it](mailto:coremo@ocmea.it)

---