

**FRIZIONI ELETTROMAGNETICHE  
LAMELLARI SENZA ANELLO  
COLLETTORE  
Serie ESG**

**MULTIPLATE  
ELECTROMAGNETIC CLUTCHES  
WITHOUT SLIP RING  
Model ESG**

**PRESTAZIONI (24 VCC) • PERFORMANCES (24VDC)**

tipo size	coppia - torque (Nm)		g/min rpm max	potenza - power (W)		tempo - time (ms)		lamelle plates ext/int	peso weight (Kg)
	M <sub>d</sub>	M <sub>s</sub>		20°C	120°C	inserzione engagem.	disinserz. disengag		
ESG 083	12	22	4500	34	24	170	50	2/3	1.5
ESG 094	25	45	4000	40	30	220	70	3/4	2.1
ESG 115	65	100	3800	46	38	280	100	4/5	3.4
ESG 134	130	200	3800	70	55	350	110	4/5	5.5
ESG 140	180	260	3600	75	58	360	110	4/5	6
ESG 166	240	400	3500	85	70	450	200	4/5	10
ESG 167	300	600	3500	113	84	480	210	7/6	9,5
ESG 195	480	800	3500	102	76	600	250	5/6	15
ESG 210	720	1100	2400	130	92	740	290	5/6	19
ESG 240	1200	1800	2200	150	110	890	370	6/7	27

- Per inserzioni in movimento riferirsi ai valori di coppia dinamica M<sub>d</sub> / for engagements in motion refer to dynamic torque M<sub>d</sub>  
 - Per frizione già inserita riferirsi ai valori di coppia statica M<sub>s</sub> / for engaged clutch refer to static torque M<sub>s</sub>

**DIMENSIONI (mm) - DIMENSIONS (mm)**

tipo size	A	B	C max	D H7	E	F	G	H	I	L	M	N	O	P	Q
ESG 083	83	25	18	30	51	1	34	15	5	47	7	6	6	2	4
ESG 095	95	35	30	45	56	1.5	35	19	5	52	8	8	6	2	4
ESG 115	115	40	32	50	63	1.5	38	22	6	58	10	9	8	2	4
ESG 134	134	50	40	60	73	1.5	44	28	6	68	10	12	8	3	5
ESG 140	140	55	42	60	73	1.5	44	28	6	68	12	12	8	3	5
ESG 166	166	65	52	70	82	1.5	47	33	8	76	13	12	10	3	6
ESG 167	166	70	55	60	91	0,5	51	39	7,5	84	12	19	8	3	6
ESG 195	195	70	60	94	94	1	50	42	9	83	16	13	12	4	7
ESG 210	210	85	70	75	108	2	53	46	10	91	18	11,5	12	4	8
ESG 240	240	95	80	90	110,5	2	56	50	10	98	19,5	13,5	12	4	10

**DENOMINAZIONE PARTI - PARTS NAME**

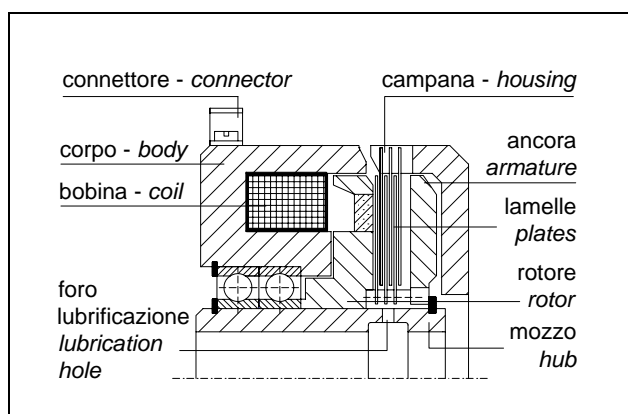

**ESEMPIO MONTAGGIO - MOUNTING SAMPLE**

