

**FRIZIONI
ELETTROMAGNETICHE
LAMELLARI
CON ANELLO COLLETORE
Serie ERC**

**MULTIPLATE
ELECTROMAGNETIC
CLUTCHES WITH SLIP RING
Model ERC**

PRESTAZIONI (24 VCC) • PERFORMANCES (24VDC)

tipo size	coppia – torque (Nm)		potenza - power (W)		tempo - time (ms)		lamelle plates ext/ int	peso weight (Kg)
	M _d	M _s	20°C	120°C	inserzione engagem.	disinserz. disengang		
ERC 083	10	20	18	13	170	50	5/4	1
ERC 094	25	50	18	13	220	70	5/4	1.4
ERC 115	50	100	28	20	280	100	5/4	2.5
ERC 134	115	200	38	27	340	110	5/4	3.3
ERC 140	120	220	39	28	360	120	5/4	3.8
ERC 166	200	400	52	38	450	200	6/5	6
ERC 195	400	800	80	58	600	260	7/6	12
ERC 210	600	1100	92	68	730	280	7/6	13
ERC 240	1000	1800	92	68	880	360	7/6	16

- per inserzioni in movimento riferirsi ai valori di coppia dinamica M_d - for engagements in motion refer to dynamic torque M_d
- per frizione già inserita riferirsi ai valori di coppia statica M_s - for clutch allready engaged refer to static torque M_s

DIMENSIONI (mm) - DIMENSIONS (mm)

tipo - size	A	B	C max	E	H	J	K	L	M	P	Q
ERC 083	30	83	34	34	18,5	8	16,5	41	3 x M4	10	5,5
ERC 094	36	92	36	45	23	10	20	50	4 x M6	10	5,5
ERC 115	45,5	114	46	52	26	15	23	60	4 x M6	12	6
ERC 134	52	134	52	63	29	18	26	72	4 x M8	15	7
ERC 140	52	140	62	68	29	18	26	80	4 x M6	15	7
ERC 166	58,5	166	72	75	33	20	30	92	5 x M10	15	7
ERC 195	68,5	195	82	90	36,5	25	33,5	110	5 x M10	18	7
ERC 210	73,5	210	92	96	38	26	35	120	5 x M10	20	8,5
ERC 240	77	240	102	112	40	28	37	140	5 x M12	20	8,5

DENOMINAZIONE PARTI - PARTS NAME

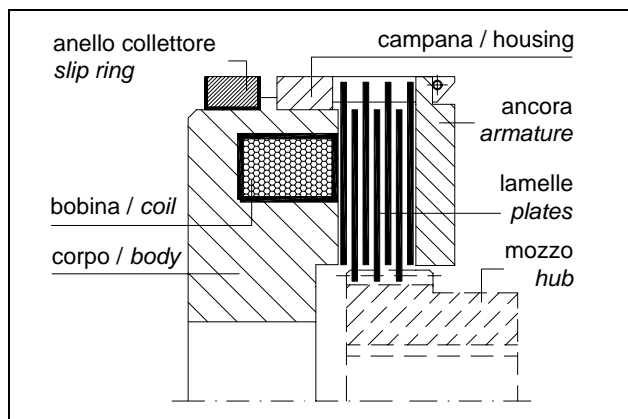

ESEMPIO MONTAGGIO- MOUNTING EXAMPLE

