

**FRENI ELETTRICITÀ
LAMELLARI
Serie ERB**

**MULTIPLATE
ELECTROMAGNETIC BRAKES
Model ERB**

PRESTAZIONI (24 VCC) • PERFORMANCES (24VDC)

tipo size	coppia – torque (Nm)		potenza - power (W)		tempo - time (ms)		lamelle plates ext/ int	peso weight (Kg)
	M _d	M _s	20°C	120°C	Inserzione engagem.	disinserz. disengang		
ERB 083	10	20	18	13	170	50	5/4	0.8
ERB 094	25	50	18	13	220	70	5/4	1.2
ERB 115	50	100	28	20	280	100	5/4	2.1
ERB 140	100	200	39	28	360	110	5/4	3.8
ERB 166	200	400	52	38	450	200	6/5	6.4
ERB 195	400	800	80	58	600	250	7/6	9.8
ERB 210	600	1100	92	68	730	280	7/6	12
ERB 240	1000	1800	92	68	880	360	7/6	16

- per azionamenti di frenatura riferirsi alla coppia dinamica M_d - for braking operations refer to dynamic torque M_d
 - per frenatura di stazionamento riferirsi alla coppia statica M_s - for clamping refer to stationary torque M_s

DIMENSIONI (mm) - DIMENSIONS (mm)

tipo size	A	B	C max	D	E	F	G	H	L	M
ERB 083	83	73	34	41	3 x M4	10	18.5	16,5	30	34
ERB 094	94	81	36	50	4 x M6	10	23	20	36	45
ERB 115	115	100	46	60	4 x M6	12	26	23	45,5	52
ERB 140	140	125	62	80	4 x M6	15	29	26	52	68
ERB 166	166	146	72	92	5 x M10	18	33	30	58,5	75
ERB 195	195	170	82	110	5 x M10	20	36,5	33,5	68,5	90
ERB 210	210	184	92	120	5 x M10	20	38	35	73,5	96
ERB 240	240	216	102	140	5 x M12	20	40	37	77	112

DENOMINAZIONE PARTI - PARTS NAME

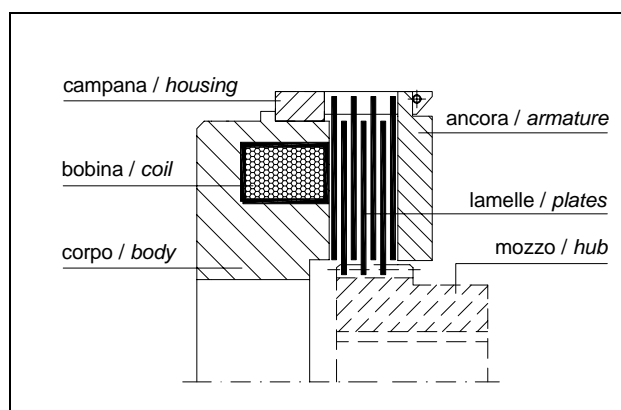

ESEMPIO MONTAGGIO- MOUNTING EXAMPLE

