

Eaton Corporation
Airflex Division
9919 Clinton Road
Cleveland, Ohio 44144-1077

Phone (216) 281-2211
Fax: (216) 281-3890



Constricting Type Clutches and Brakes

B

Constricting Features	B-1
Element Descriptions	B-3
CB Elements	B-5
Technical and Dimensional Data	B-9
Clutch and Brake Applications	B-15
Mounting Components	B-40
VC Elements	B-45
Technical and Dimensional	B-49
Clutch and Brake Applications	B-57
Mounting Components	B-77
CM Elements	B-88
Selection Procedure	B-92

Distribuidor Autorizado e Importador - Arten Freios e Embreagens Ltda.

Fone: (11) 5594-8333 • Fax (11) 5589-2422 - arten@arten.com.br • www.arten.com.br

How They Work

CB, CM and VC elements utilize a rugged tire-like neoprene and cord tube that expands radially inward when pressurized. The constricting tube forces friction shoes against an outer cylindrical drum surface. The rate at which the tube is pressurized determines the rate at which element torque increases. Final tube pressure determines the element torque capacity.

Design Features

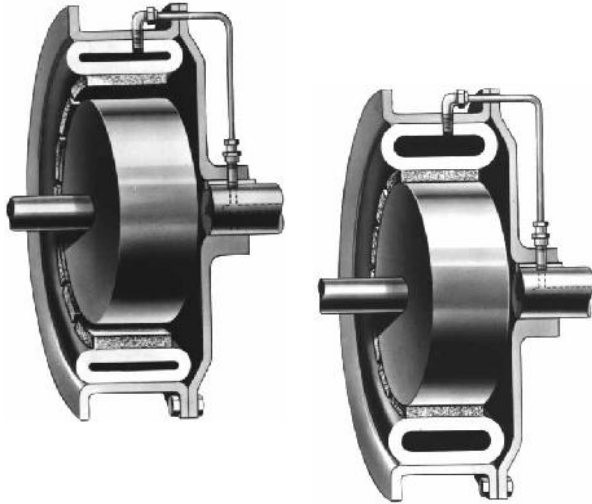

Plate Clutch



Drum Clutch

- **Force applied at maximum radius from axis**

Airflex constricting elements concentrates the frictional force on the outside drum diameter thereby achieving maximum torque. The torque lever arm is the drum radius, not a reduced radius as occurs in plate clutches. Not only is the force generated at the optimum radius, it is also applied uniformly around the drum circumference.

- **Uniform contact velocity**

Friction shoe contact occurs across the cylindrical surface of the drum where the contact velocity is constant unlike plate types where the contact velocity varies across the friction plate face.

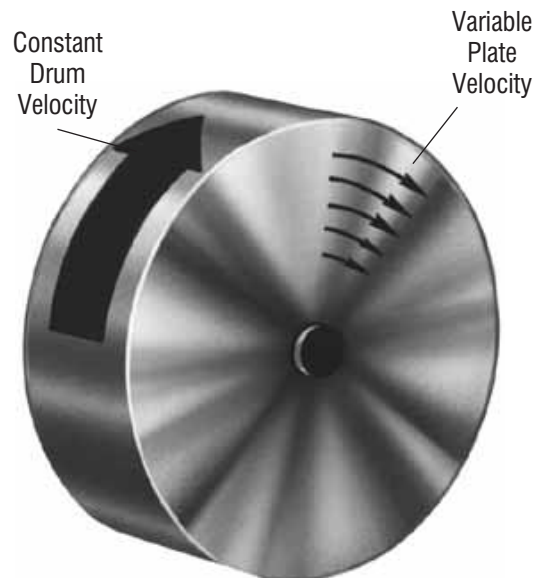

- **Self-adjustment**

As friction surfaces wear, the tube constricts further and compensates for the wear. Normal wear will not reduce torque capacity.

- **No lubrication**

There are no close fitting sliding components which require lubrication.

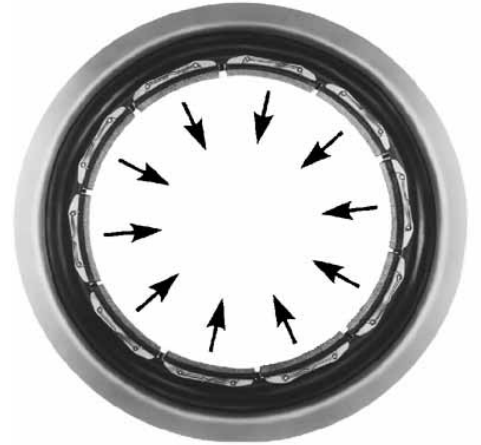

- **Centrifugal force assists clutch disengagement**

Upon release of tube pressure, centrifugal force, acting on the friction shoes at the rotating element, helps retract the shoes away from the drum surface. The centrifugal effect expels the tube pressurizing media and minimizes the possibility of disengaged friction shoe drag.



- **Operates in any plane**

The constricting design combined with centrifugal effects permits clutch operation in any plane. A plate clutch operates best in a vertical plane.

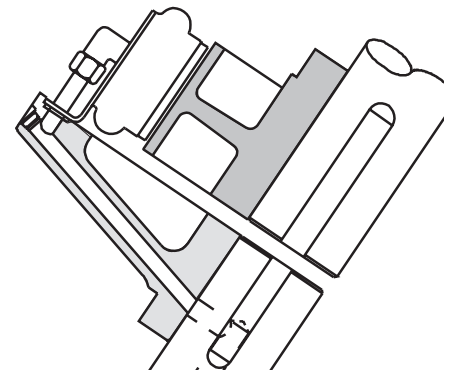

- **Gap mounting**

The constricting drum design allows a gap between the ends of the driving and driven shafts. This gap provides a space through which the element and drum can be removed to permit shaft alignment, clutch maintenance without disturbing existing shaft alignment and the removal of driving or driven components.

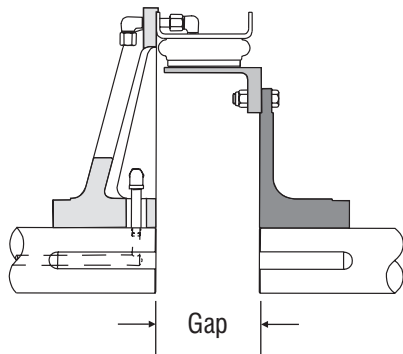

Elements are described by the number and type of fitting used to make the connection from the tube valve to the rim flange, the type of friction material and any special rim features. Since most of the special rim features pertain to CB elements only, the CB cross section has been used in the illustrations. A glossary of commonly used descriptive terms with their abbreviations in parenthesis follow:

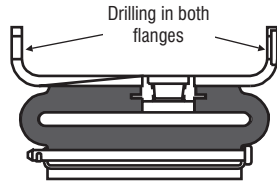

Dual drilled (DD) - Both flanges of the rim are drilled for air and/or mounting connections. Required for one of the elements used in a dual element and for air bridge mounting.

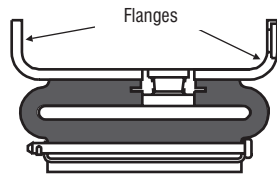

Dual flange (DFL) - A CB description for rims with two flanges. Standard on element sizes 16CB500 thru 45CB525. This description used primarily to differentiate between the single and dual flanged 12CB and 14CB elements.

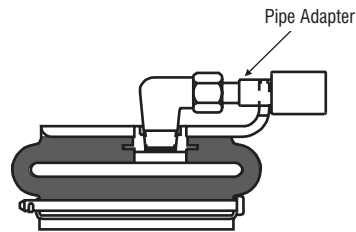

Pipe adapter - An adapter to connect standard tube fittings to pipe fittings.

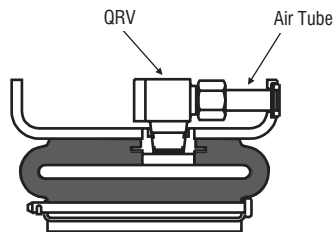

Quick release valve (QRV) - The plumbing from the valve to the rim flange incorporating a quick release valve and air tube.

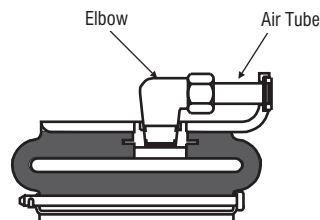

Side connection (SC) - The plumbing from the valve to the rim flange incorporating an elbow and air tube.

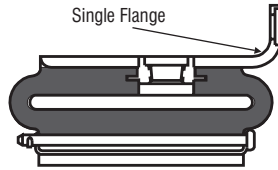

Single flange (SGL FL) - A CB description for rims having one flange. Element sizes 3CB150 thru 10CB300 have one flange. Element sizes 12CB350 and 14CB400 can be furnished single or dual flanged.

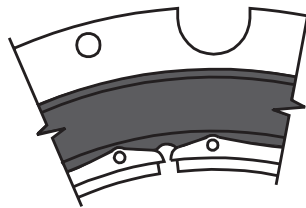

Slotted rim (SLOT) - A U-shaped cutout in the rim flange providing clearance for piping directly to the valve. Used with pipe adapter and in the small CB clutch applications which incorporate tapered bushings.

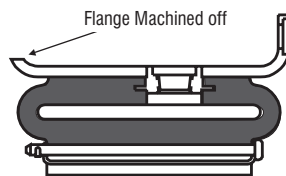

Turned down flange (TDF) - Applies to CB elements only. Element sizes 16CB500 thru 45CB525 have dual flange rims. This description is used when one flange is removed or “turned down” to provide clearance for adjacent components. Used primarily in FSPA applications.

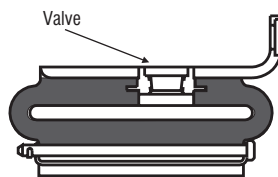

Valve (VA or VAL or VL) - That part of the tube which permits a mechanical connection and through which the activating media enter and exhausts. Element sizes 3CB150 thru 14CB400 and 11.5VC500 can be furnished with either one or two valves; larger sizes with either one, two or four valves.

Lining (LNG or LN) or Friction lining (FR LNG) - Elements can be furnished with linings having different coefficients of friction. When no mention is made in the element description, standard linings are furnished. The lining descriptions are:

- **Standard lining** - This lining will produce the published element torque ratings.
- **Low coefficient (LO-CO) or Slip lining** - Lining that has a lower coefficient of friction than the standard lining. Used primarily for continuous slip or tensioning applications.
- **High coefficient (HI-CO) or Cork lining** - Lining that has a higher coefficient of friction than the standard lining. Used primarily in applications in which the elements operate in the engaged or locked up position for extended periods of time.



Single Flange Element



Dual Flange Element

The type CB element assembly is designed and built to provide dependable clutch or brake service in the most exacting industrial applications. It is suited to high speed, cyclic operations, as well as for coupling and general power transmission.

CB design, construction and operation is quite simple. A neoprene rubber tube reinforced with several plies of cord is bonded on its outside diameter to a steel rim. Friction shoes are attached to the tube's inside diameter by pins which in turn are held in position by lockwires, except for sizes 3CB150 through 5CB200 which have friction material bonded to the rubber tube. Pressurizing the tube forces the friction shoes to engage around a cylindrical drum.

Element torque capacity is dependent upon the applied pressure and rotating speed. Catalog ratings are given at 75 psi (5.2 bar)

and zero rpm. Maximum recommended pressure is 110 psi (7.6 bar). Adjustment for speed is explained under Selection Procedure.

CB elements are available in 20 sizes which are identified by the drum diameter in inches on which they constrict and the width in inches of its friction lining. For instance, size 16CB500 is designed to constrict on a 16 inch diameter drum and has a friction lining width of 5 inches. The smallest CB element will constrict on a 3 inch (76mm) diameter drum and the largest on a 45 inch (1143mm) diameter drum.

Element sizes 3CB150 through 10CB300 have rims with one flange. Element sizes 12CB350 and 14CB400 are normally furnished with rims having one flange; however, they can also be furnished, when specified, with two flanges. Element sizes

16CB500 and larger have rims with two flanges. CB elements are grouped and described as being single flanged or dual flanged elements.

Two dual flanged elements can be bolted together to form a dual element having twice the torque capacity of a single element. Dual elements can be furnished in sizes 12CB350 through 45CB525.

Because the rubber tube is the connecting member between the driving and driven shafts, the CB design offers the following features in addition to the constricting features described earlier in this section.

One moving component

The tube is the only moving component. There are no springs or sliding parts.

Cushioned action

The tube transmits the torque through its side walls, cushioning damaging shock loads thereby protecting drive components. The rubber tube construction dampens the effects of torsional vibrations.

Flexible coupling

The tube flexibility is able to compensate for minor shaft misalignment and axial movement.

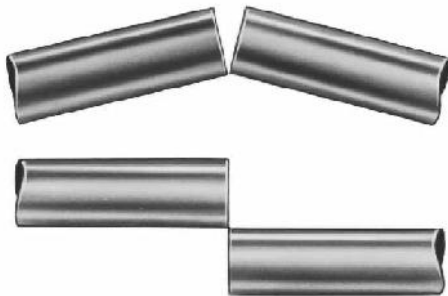

Split Elements

Element sizes 6CB200 and up are available in a split configuration. They are used in applications where there is limited axial space for maintenance or where the drum is mounted between bearings and the shaft cannot be moved for maintenance. Sizes through the 10CB300 can only be used as brakes. Larger sizes can also be used in relatively low-speed clutch applications. Note that split tubes are not as durable as standard continuous tube.



The following pages give additional descriptive information, selection procedures and common clutch and brake arrangements for the complete CB product line.

Size	Torque Rating	
	lb • in @ 75 psi	N • m @ 5,2 bar
3CB150	360	41
4CB200	1,000	113
5CB200	1,460	165
6CB200	2,040	231
8CB250	4,290	485
10CB300	8,150	921
12CB350	13,300	1500
14CB400	19,700	2230
16CB500	35,200	3980
18CB500	44,000	4970
20CB500	53,600	6060
22CB500	62,300	7040
24CB500	75,000	8480
26CB525	92,400	10400
28CB525	106,000	12000
30CB525	121,000	13700
32CB525	137,000	15500
36CB525	172,000	19400
40CB525	211,000	23800
45CB525	260,000	29400

Where Used:

- **Can Making Machinery**
- **Commercial Laundry Equipment**
- **Metal Forming Machinery**
- **Oil Field Machinery**
- **Printing Machinery**
- **Rubber Processing Machinery**
- **Tire Building Machinery**

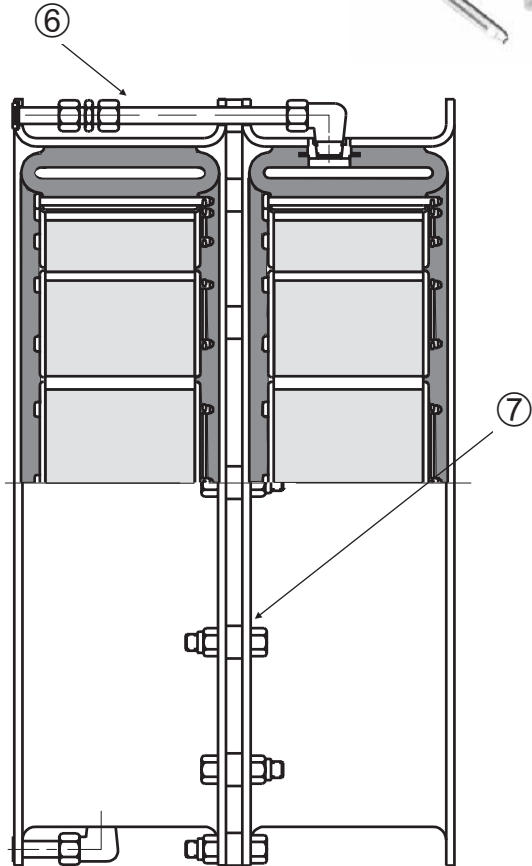
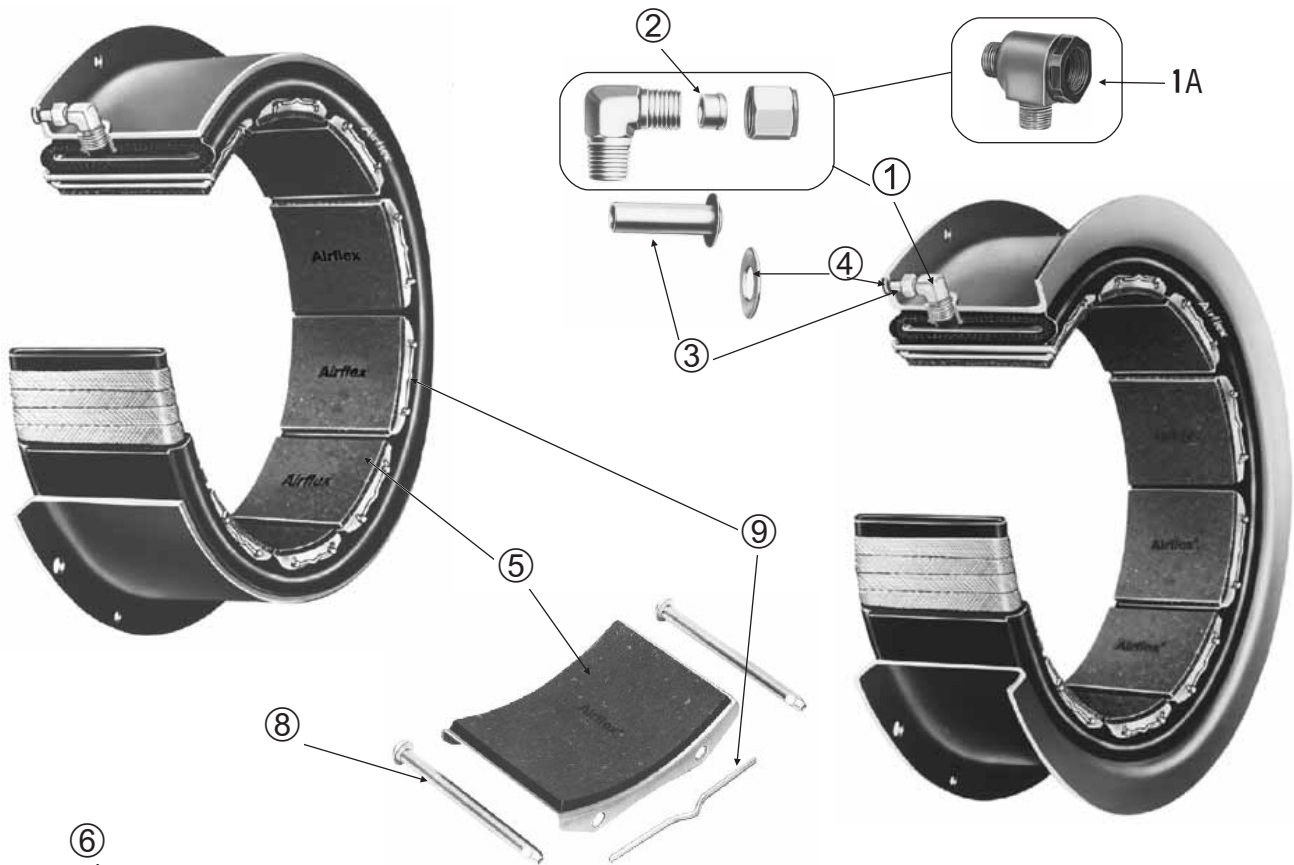

Item	Component Description
1	Elbow Assembly
1A ①	Optional - Quick Release Valve Assembly
1B ①	Optional - Quick Release Valve Muffler
2	Compression Ring
3	Air Connection Tube
4	Air Connection Gasket
5 ②	Friction Shoe Assembly
6	Air Tube Group (Dual Mounted)
7	Spacer Group (Dual Mounted)
8 ②	Shoe Pin
9 ②	Lockwire
5, 8&9	Friction Shoe Replacement Kit

Notes:

- ① This option not available for sizes 3 thru 14.
- ② These items are not applicable to sizes 3 thru 5. The friction material is bonded to the rubber tube and is not replaceable.

A double alpha suffix is added to the basic element part number to completely describe the element configuration.

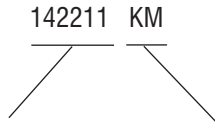

Basic Part No.

Configuration

Alpha Suffixes for 3 thru 14 CB Elements				
No. of Valves or Side Connections	Type of Lining	Special Rim Features	Alpha Suffixes	
			Valves Only	With Side Connections
1	Standard		JA	JB
1	Standard	Slotted	JC	
1	Cork		JT	JN
1	Cork	Slotted	JU	
2	Standard		JH	JG
2	Standard	Slotted	JK	
2	Cork			JQ

The basic element part number is shown on the element catalog pages. Alphas for the more common element configurations are shown on this page. The element part number used in the above example identifies a 16CB500 element equipped with standard friction linings and one side connection.

Alpha Suffixes for 16 thru 45 CB Elements					
No. of Valves, Side Connections, or QRV's	Type of Lining	Special Rim Features	Alpha Suffixes		
			Valves only	with Side Connections	with QRV's
1	Standard		KY	KM	KN
1	Standard	Dual Drilled	KS	LH	LJ
1	Cork		LQ	MG	LA
1	Cork	Dual Drilled	LR		
2	Standard		LX	LB	LK
2	Standard	Dual Drilled	MT		LW
2	Cork		KD	KE	
2	Cork	Dual Drilled	LY	KL	
4	Standard		KZ	KP	KR
4	Standard	Dual Drilled	LS	KT	KU
4	Cork		NR	LV	ML
4	Cork	Dual Drilled	LT	LU	NE

Alpha Suffixes for Dual 12 thru 45 CB Elements ^②				
No. of Side Connections or QRV's	Type of Lining	Alpha Suffix		
		with Side Connections	with QRV's	
2	Standard	DA	DD	
2	Cork	DF	DJ	
4	Standard	DK	DL	
4	Cork	DT		

Notes:

- ① Not available for sizes 3 thru 5.
- ② Dual sizes 12 and 14 elements only available with suffixes DA and DF.

English		lb in @ 75 psi	rpm	psi/rpm ²	lb ft ²	lb	in ²	inches		in ³	inches
3CB150	142252	360	2000	1.5 E-06	0.1	1.8	14	0.20	0.04	7	2.90
4CB200	142840	1000	2000	1.7 E-06	0.2	2.5	23	0.12	0.03	10	3.90
5CB200	142253	1460	2000	2.0 E-06	0.4	3.5	30	0.20	0.04	17	4.90
6CB200	142095	2040	1800	6.0 E-06	1.0	7.0	36	0.14	0.06	19	5.90
8CB250	142096	4290	1800	7.0 E-06	2.0	9.0	61	0.12	0.06	30	7.90
10CB300	142197	8150	1800	10.0 E-06	6.0	19.0	91	0.20	0.06	50	9.90
12CB350	142098	13300	1800	12.0 E-06	11.0	26.0	128	0.20	0.06	80	11.90
14CB400	142087	19700	1800	15.0 E-06	17.0	31.0	170	0.20	0.06	70	13.90

Size	Part Number	M _t ² Torque Rating	Maximum Speed	C _s Centrifugal Loss Constant	Wk ² J	Weight Mass	Friction Area	New Worn		Air Tube Cavity	Minimum Drum Diameter
								Friction	Lining Thickness		
								New	Worn		
3CB150	142252	40,7	2000	0,10 E-06	0,00	0,8	90,3	5	1	0,12	74
4CB200	142840	113	2000	0,12 E-06	0,01	1,1	148,4	3	1	0,17	99
5CB200	142253	165	2000	0,14 E-06	0,02	1,6	193,5	5	1	0,28	124
6CB200	142095	231	1800	0,41 E-06	0,04	3,2	232,2	4	2	0,32	150
8CB250	142096	485	1800	0,48 E-06	0,08	4,1	393,5	3	2	0,49	201
10CB300	142197	921	1800	0,69 E-06	0,25	8,6	587,0	5	2	0,82	251
12CB350	142098	1500	1800	0,83 E-06	0,46	12	825,6	5	2	1,31	302
14CB400	142087	2230	1800	1,04 E-06	0,71	14	1096,5	5	2	1,15	353

SI		N m @ 5, 2 bar	rpm	bar/rpm ²	kg m ²	kg	cm ²	millimeters		dm ³	millimeters
----	--	-------------------	-----	----------------------	-------------------	----	-----------------	-------------	--	-----------------	-------------

Notes:

- ① Refers to basic part number only. When ordering, the number of air inlets and type of connection must be specified.
- ② Dynamic torque shown, static torque approximately 25% greater. Torque in each application is dependent upon air pressure and speed.
- ③ Tolerance for sizes:
3 thru 5
+0.000/-0.003 in (+0,00/-0,08 mm)
6 and larger
+0.000/-0.005 in (+0,00/-0,13 mm)
- ④ American National Pipe Thread.
Sizes 3 thru 5 only available with one air inlet. All other sizes available with either one or two air inlets.
- ⑤ Maximum rpm is dependent upon operating conditions and varies for each application. Consult factory for applications exceeding these speeds.
- ⑥ Drum contact with worn shoes.

Airflex® Single CB Elements



Form CB-401

Dimensional Data – Sizes 3 to 14

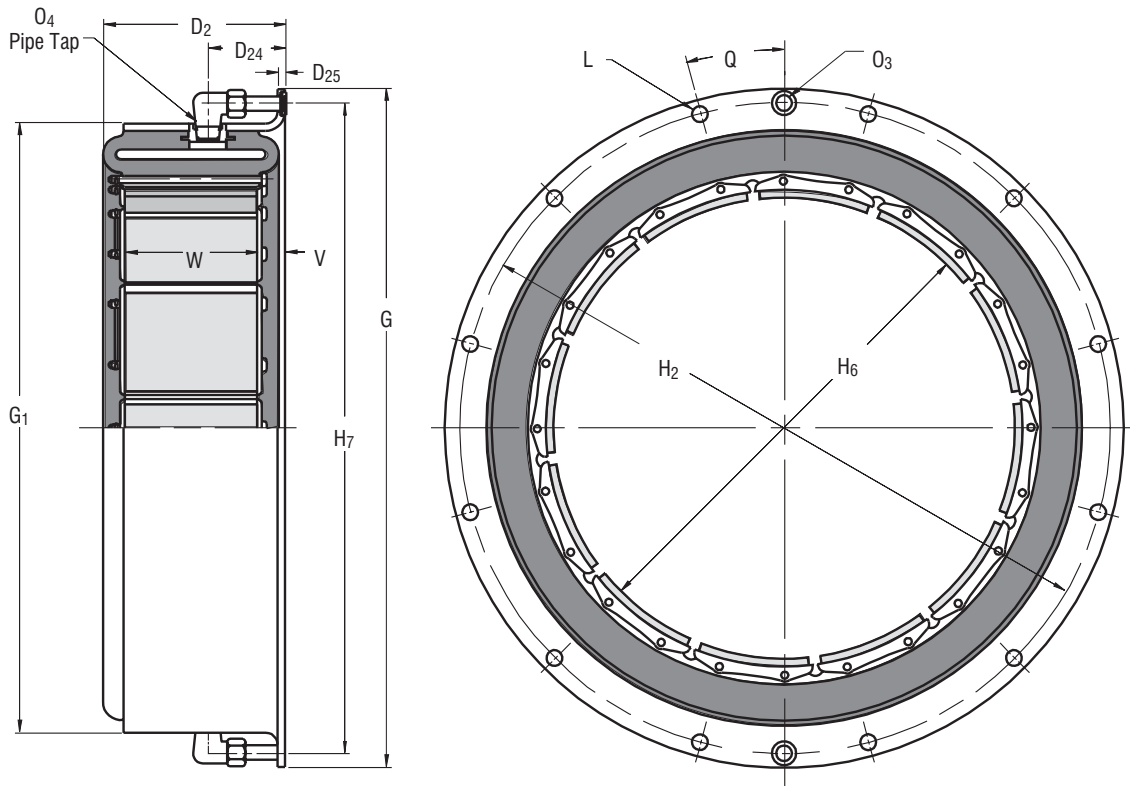

English		lbin @ 75 psi	Dimensions in inches															
3CB150	142252	360	2.16	1.18	0.10	6.299	4.86	5.748	3.15	5.75	8	0.25	0.28	1/8-27	22.500	0.35	6	1.50
4CB200	142840	1000	2.63	1.38	0.09	7.248	5.81	6.688	4.13	6.69	8	0.25	0.19	1/8-27	22.500	0.38	6	2.00
5CB200	142253	1460	2.85	1.50	0.10	8.819	7.20	8.071	5.16	8.07	8	0.31	0.29	1/8-27	22.500	0.48	6	2.00
6CB200	142095	2040	2.94	1.56	0.09	10.752	9.06	10.000	6.16	10.00	8	0.38	0.31	3/8-18	22.500	0.56	6	2.00
8CB250	142096	4290	3.44	1.91	0.09	12.875	11.19	12.125	8.16	12.13	8	0.38	0.31	3/8-18	22.500	0.56	8	2.50
10CB300	142197	8150	4.13	2.00	0.19	15.373	13.63	14.625	10.13	14.63	12	0.38	0.31	3/8-18	15.000	0.69	10	3.00
12CB350	142098	13300	4.72	2.00	0.19	17.625	15.88	16.875	12.13	16.88	14	0.38	0.31	3/8-18	12.857	0.69	12	3.50
14CB400	142087	19700	5.22	2.00	0.19	19.625	17.88	18.875	14.13	18.88	16	0.38	0.31	3/8-18	11.250	0.69	14	4.00
Size	Part Number	M, Torque Rating	D ₂	D ₂₄	D ₂₅	G	G ₁	H ₂	H ₆	H ₇	O ₃		Q (Deg)	V	W			
											No	.Size			No	Width		
											L (Bolt)	.Size			No	Width		
3CB150	142252	40,7	55	30	2	160,0	123	146,0	80	146	8	6	7	1/8-27	22,500	9	6	38
4CB200	142840	113	67	35	2	184,1	148	169,9	105	170	8	6	5	1/8-27	22,500	10	6	51
5CB200	142253	165	72	38	2	224,0	183	205,0	131	205	8	8	7	1/8-27	22,500	12	6	51
6CB200	142095	231	75	40	2	273,1	230	254,0	156	254	8	10	8	3/8-18	22,500	14	6	51
8CB250	142096	485	87	48	2	327,0	284	308,0	207	308	8	10	8	3/8-18	22,500	14	8	64
10CB300	142197	921	105	51	5	390,5	346	371,5	257	371	12	10	8	3/8-18	15,000	17	10	76
12CB350	142098	1500	120	51	5	447,7	403	428,6	308	429	14	10	8	3/8-18	12,857	17	12	89
14CB400	142087	2230	133	51	5	498,5	454	479,4	359	479	16	10	8	3/8-18	11,250	17	14	102
SI		Nm @ 5, 2 bar	Dimensions in millimeters															

English		lb in @ 75 psi	rpm	psi/rpm ²	lb ft ²	lb	in ²	Inches		in ³	inches
12CB350	142098	13000	1800	12 E-06	12	30	128	0.20	0.06	80	11.90
14CB400	142087	19700	1800	15 E-06	21	35	170	0.20	0.06	70	13.90
16CB500	142211	35200	1550	20 E-06	52	74	241	0.26	0.06	140	15.87
18CB500	142264	44000	1400	23 E-06	70	81	262	0.26	0.06	160	17.87
20CB500	142265	53600	1300	25 E-06	90	88	288	0.26	0.06	170	19.87
22CB500	142266	62300	1250	28 E-06	114	95	312	0.26	0.06	190	21.87
24CB500	142267	75000	1200	30 E-06	142	102	338	0.26	0.06	200	23.87
26CB525	142268	92400	1100	34 E-06	210	133	404	0.33	0.06	260	25.81
28CB525	142269	106000	1000	37 E-06	252	140	430	0.33	0.06	280	27.81
30CB525	142270	121000	950	40 E-06	303	148	458	0.33	0.06	290	29.81
32CB525	142271	137000	900	43 E-06	359	157	483	0.33	0.06	310	31.81
36CB525	142272	172000	800	48 E-06	510	178	550	0.33	0.06	350	35.81
40CB525	142273	211000	750	52 E-06	730	201	610	0.33	0.06	380	39.81
45CB525	142081	260000	670	64 E-06	1115	262	675	0.33	0.06	430	44.75

Size	Part Number ^①	M _r Torque Rating ^②	Maximum Speed ^③	C _s Centrifugal Loss Constant	Wk ² J	Weight Mass	Friction Area	Friction Lining Thickness		Air Tube Cavity ^⑦	Minimum Drum Diameter
								New	Worn		
								New	Worn		
12CB350	142098	1470	1800	0,83 E-06	0,50	14	826	5	2	1,31	302
14CB400	142087	2230	1800	1,04 E-06	0,88	16	1097	5	2	1,15	353
16CB500	142211	3980	1550	1,38 E-06	2,18	34	1554	7	2	2,30	403
18CB500	142264	4970	1400	1,59 E-06	2,94	37	1690	7	2	2,62	454
20CB500	142265	6060	1300	1,73 E-06	3,78	40	1858	7	2	2,79	505
22CB500	142266	7040	1250	1,93 E-06	4,79	43	2012	7	2	3,12	555
24CB500	142267	8480	1200	2,07 E-06	5,96	46	2180	7	2	3,28	606
26CB525	142268	10400	1100	2,35 E-06	8,82	60	2606	8	2	4,26	656
28CB525	142269	12000	1000	2,55 E-06	10,58	63	2774	8	2	4,59	706
30CB525	142270	13700	950	2,76 E-06	12,73	67	2954	8	2	4,76	757
32CB525	142271	15500	900	2,97 E-06	15,08	71	3115	8	2	5,08	808
36CB525	142272	19400	800	3,31 E-06	21,42	81	3548	8	2	5,74	910
40CB525	142273	23800	750	3,59 E-06	30,66	91	3935	8	2	6,23	1011
45CB525	142081	29400	670	4,42 E-06	46,83	119	4354	8	2	7,05	1137

SI		Nm @ 5,2 bar	rpm	bar/rpm ²	kg m ²	kg	cm ²	millimeters		dm ³	millimeters
----	--	-----------------	-----	----------------------	-------------------	----	-----------------	-------------	--	-----------------	-------------

Notes:

- ① Refers to basic part number only. When ordering, the number of air inlets and type of connection must be specified.
- ② Dynamic torque shown, static torque approximately 25% greater. Torque in each application is dependent upon air pressure and speed.
- ③ Tolerance for sizes:
12 thru 24, 28 and 32
+0.000/-0.005 in (+0,00/-0,13 mm)
26 and 30
+0.000/-0.008 in (+0,00/-0,20 mm)
36 thru 45
+0.000/-0.010 in (+0,00/-0,25 mm)
- ④ American National Pipe Thread.
Sizes 12 and 14 available with one or two air inlets. All other sizes available with one, two or four air inlets.
- ⑤ 10.00 degrees for elements with one air inlet, 5.00 degrees for elements with two or four air inlets.
- ⑥ Maximum rpm is dependent upon operating conditions and varies for each application. Consult factory for applications exceeding these speeds.
- ⑦ Drum contact with worn shoes.

Airflex® Single CB Elements



Form CB-402

Dimensional Data – Sizes 12 to 45

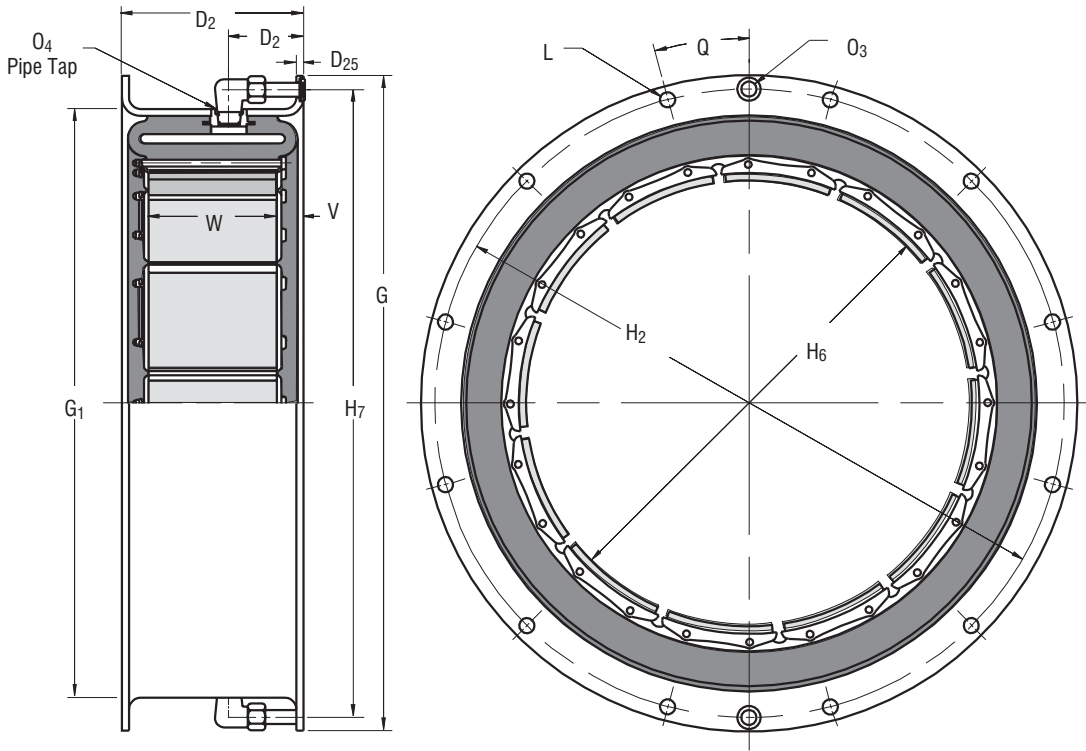

English	lb in @ 75 psi	Dimensions in inches																
12CB350	142098	13300	4.88	2.00	0.19	17.625	15.88	16.875	12.13	16.88	14	0.375	0.31	3/8-18	12.857	0.69	12	3.50
14CB400	142087	19700	5.38	2.00	0.19	19.625	17.88	18.875	14.13	18.88	16	0.375	0.31	3/8-18	11.250	0.69	14	4.00
16CB500	142211	35200	6.63	2.50	0.19	23.500	20.75	22.500	16.19	22.25	8	0.500	0.38	3/8-18	22.500	0.81	10	5.00
18CB500	142264	44000	6.63	2.50	0.19	25.500	22.75	24.375	18.19	24.38	12	0.500	0.38	3/8-18	15.000	0.81	11	5.00
20CB500	142265	53600	6.63	2.50	0.19	27.500	24.75	26.375	20.19	26.38	12	0.500	0.38	3/8-18	15.000	0.81	12	5.00
22CB500	142266	62300	6.63	2.50	0.19	29.500	26.75	28.375	22.19	28.38	12	0.500	0.38	3/8-18	15.000	0.81	13	5.00
24CB500	142267	75000	6.63	2.50	0.19	31.500	28.75	30.375	24.19	30.38	16	0.500	0.38	3/8-18	11.250	0.81	14	5.00
26CB525	142268	92400	6.94	2.50	0.25	34.000	31.00	32.750	26.19	32.50	16	0.625	0.50	1/2-14	11.250	0.84	16	5.25
28CB525	142269	106000	6.94	2.50	0.25	36.000	33.00	34.750	28.19	34.50	16	0.625	0.50	1/2-14	11.250	0.84	17	5.25
30CB525	142270	121000	6.94	2.50	0.25	38.000	35.00	36.750	30.19	36.50	16	0.625	0.50	1/2-14	11.250	0.84	18	5.25
32CB525	142271	137000	6.94	2.50	0.25	40.000	37.00	38.750	32.19	38.50	18	0.625	0.50	1/2-14	5	0.84	19	5.25
36CB525	142272	172000	6.94	2.75	0.28	44.625	41.56	43.125	36.19	43.25	18	0.750	0.63	3/4-14	5	0.84	22	5.25
40CB525	142273	211000	6.94	2.75	0.28	48.625	45.56	47.125	40.19	47.25	20	0.750	0.63	3/4-14	9.000	0.84	24	5.25
45CB525	142081	260000	6.94	2.75	0.28	53.625	50.69	52.125	45.19	52.25	24	0.750	0.63	3/4-14	7.500	0.84	27	5.25
Size	① Part Number	M _t ^② Torque Rating	D ₂	D ₂₄	D ₂₅	G	G ₁	H ₂	H ₆	H ₇	No. Size		④		Q (Deg)	V	No. Width	
											L (Bolt)	O ₃	O ₄	W			No.	Width
12CB350	142098	1500	124	51	5	447,7	403	428,6	308	429	14	10	8	3/8-18	12,857	17	12	89
14CB400	142087	2230	137	51	5	498,5	454	479,4	359	479	16	10	8	3/8-18	11,250	17	14	102
16CB500	142211	3980	168	64	5	596,9	527	571,5	411	565	8	13	10	3/8-18	22,500	21	10	127
18CB500	142264	4970	168	64	5	647,7	578	619,1	462	619	12	13	10	3/8-18	15,000	21	11	127
20CB500	142265	6060	168	64	5	698,5	629	669,9	513	670	12	13	10	3/8-18	15,000	21	12	127
22CB500	142266	7040	168	64	5	749,3	679	720,7	564	721	12	13	10	3/8-18	15,000	21	13	127
24CB500	142267	8480	168	64	5	800,1	730	771,5	614	772	16	13	10	3/8-18	11,250	21	14	127
26CB525	142268	10400	176	64	6	863,6	787	831,9	665	826	16	16	13	1/2-14	11,250	21	16	133
28CB525	142269	12000	176	64	6	914,4	838	882,7	716	876	16	16	13	1/2-14	11,250	21	17	133
30CB525	142270	13700	176	64	6	965,2	889	933,5	767	927	16	16	13	1/2-14	11,250	21	18	133
32CB525	142271	15500	176	64	6	1016,0	940	984,3	818	978	18	16	13	1/2-14	5	21	19	133
36CB525	142272	19400	176	70	7	1133,5	1056	1095,4	919	1099	18	19	16	3/4-14	5	21	22	133
40CB525	142273	23800	176	70	7	1235,1	1157	1197,0	1021	1200	20	19	16	3/4-14	9,000	21	24	133
45CB525	142081	29400	176	70	7	1362,1	1287	1324,0	1148	1327	24	19	16	3/4-14	7,500	21	27	133
SI	N m @ 5,2 bar		Dimensions in millimeters															

English		lb in @ 75 psi	rpm	psi/rpm ²	lb ft ²	lb	in ²	inches		in ³	inches
12CB350	142731	26600	1800	12 E-06	25	62	256	0.20	0.06	160	11.90
14CB400	142604	39400	1800	15 E-06	42	75	340	0.20	0.06	140	13.90
16CB500	142432	70400	1550	20 E-06	106	151	482	0.26	0.06	280	15.87
18CB500	142433	88000	1400	23 E-06	144	166	524	0.26	0.06	320	17.87
20CB500	142434	107200	1300	25 E-06	185	180	576	0.26	0.06	340	19.87
22CB500	142435	124600	1250	28 E-06	233	194	624	0.26	0.06	380	21.87
24CB500	142436	150000	1200	30 E-06	292	209	676	0.26	0.06	400	23.87
26CB525	142437	184800	1050	34 E-06	432	272	808	0.33	0.06	520	25.81
28CB525	142438	212000	1000	37 E-06	517	286	860	0.33	0.06	560	27.81
30CB525	142439	242000	950	40 E-06	621	302	916	0.33	0.06	580	29.81
32CB525	142440	274000	900	43 E-06	736	321	966	0.33	0.06	620	31.81
36CB525	142441	344000	800	48 E-06	1052	366	1100	0.33	0.06	700	35.81
40CB525	142442	422000	750	52 E-06	1502	413	1220	0.33	0.06	760	39.81
45CB525	142443	520000	670	64 E-06	2293	537	1350	0.33	0.06	860	44.75

Size	① Part Number	② M, Torque Rating	③ Maximum Speed	C _s Centrifugal Loss Constant	Wk ² J	Weight Mass	Friction Area	Friction Lining Thickness		Air Tube Cavity ⑦	Minimum Drum Diameter
								New	Worn		
								New	Worn		
12CB350	142731	3010	1800	0,83 E-06	1,05	28	1651	5	2	2,62	302
14CB400	142604	4450	1800	1,04 E-06	1,76	34	2193	5	2	2,30	353
16CB500	142432	7960	1550	1,38 E-06	4,45	68	3109	7	2	4,59	403
18CB500	142433	9940	1400	1,59 E-06	6,05	75	3380	7	2	5,25	454
20CB500	142434	12100	1300	1,73 E-06	7,77	82	3715	7	2	5,58	505
22CB500	142435	14100	1250	1,93 E-06	9,79	88	4025	7	2	6,23	555
24CB500	142436	17000	1200	2,07 E-06	12,26	95	4360	7	2	6,56	606
26CB525	142437	20900	1050	2,35 E-06	18,14	123	5212	8	2	8,53	656
28CB525	142438	24000	1000	2,55 E-06	21,71	130	5547	8	2	9,18	706
30CB525	142439	27300	950	2,76 E-06	26,08	137	5908	8	2	9,51	757
32CB525	142440	31000	900	2,97 E-06	30,91	145	6231	8	2	10,2	808
36CB525	142441	38900	800	3,31 E-06	44,18	166	7095	8	2	11,5	910
40CB525	142442	47700	750	3,59 E-06	63,08	187	7869	8	2	12,5	1011
45CB525	142443	58800	670	4,42 E-06	96,31	243	8708	8	2	14,1	1137

SI		Nm @ 5,2 bar	rpm	bar/rpm ²	kg m ²	kg	cm ²	millimeters		dm ³	millimeters
----	--	-----------------	-----	----------------------	-------------------	----	-----------------	-------------	--	-----------------	-------------

Notes:

- ① Refers to basic part number only. When ordering, the number of air inlets and type of connection must be specified.
- ② Dynamic torque shown, static torque approximately 25% greater. Torque in each application is dependent upon air pressure and speed.
- ③ Tolerance for sizes:
12 thru 24, 28 and 32
+0.000/-0.005 in (+0,00/-0,13 mm)
26 and 30
+0.000/-0.008 in (+0,00/-0,20 mm)
36 thru 45
+0.000/-0.010 in (+0,00/-0,25 mm)
- ④ American National Pipe Thread
Sizes 12 and 14 available with two air inlets. All other sizes available with two or four air inlets.
- ⑤ 10.00 degrees for elements with one air inlet.
5.00 degrees for elements with two or four air inlets.
- ⑥ Maximum rpm is dependent upon operating conditions and varies for each application. Consult factory for applications exceeding these speeds.
- ⑦ Drum contact with worn shoes.

Airflex® Dual CB Elements



Form CB-403

Dimensional Data – Sizes 12 to 45

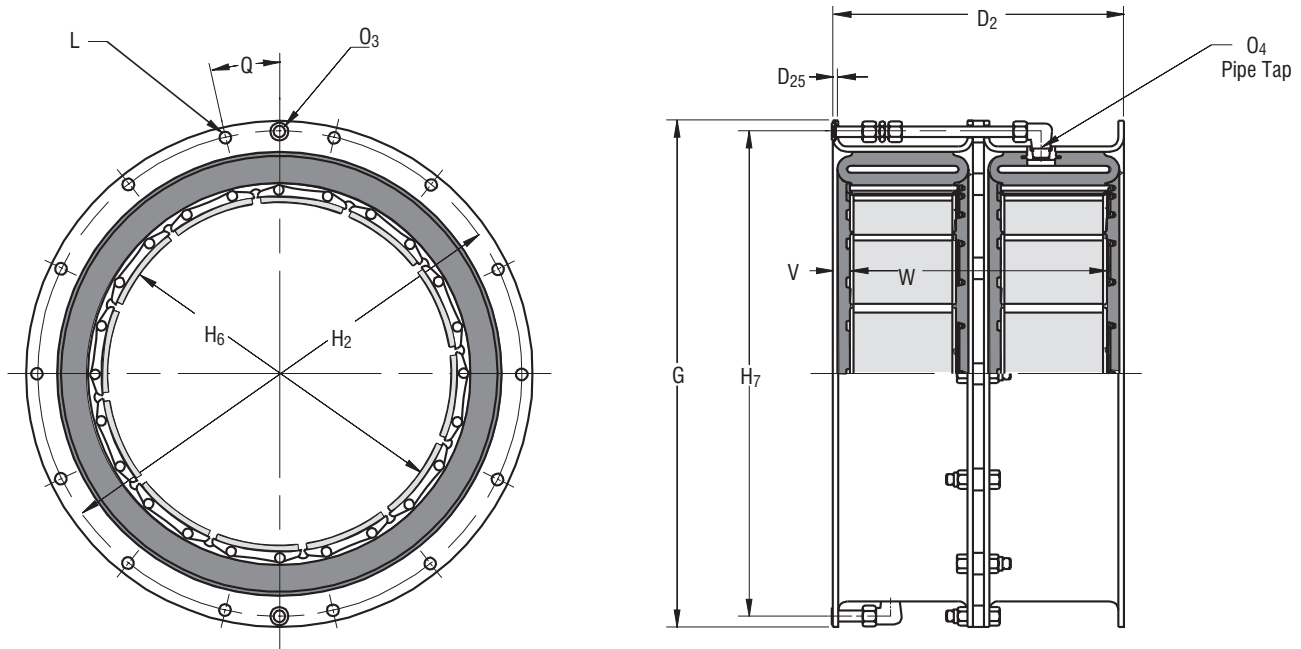

English		lb in @ 75 psi	Dimensions in inches													
12CB350	142731	26600	10.13	0.19	17.625	16.875	12.13	16.88	14	0.375	0.31	3/8-18	12.857	0.69	24	8.75
14CB400	142604	39400	11.13	0.19	19.625	18.875	14.13	18.88	16	0.375	0.31	3/8-18	11.250	0.69	28	9.75
16CB500	142432	70400	13.63	0.19	23.500	22.500	16.19	22.25	8	0.500	0.38	3/8-18	22.500	0.81	20	12.00
18CB500	142433	88000	13.63	0.19	25.500	24.375	18.19	24.38	12	0.500	0.38	3/8-18	15.000	0.81	22	12.00
20CB500	142434	107200	13.63	0.19	27.500	26.375	20.19	26.38	12	0.500	0.38	3/8-18	15.000	0.81	24	12.00
22CB500	142435	124600	13.63	0.19	29.500	28.375	22.19	28.38	12	0.500	0.38	3/8-18	15.000	0.81	26	12.00
24CB500	142436	150000	13.63	0.19	31.500	30.375	24.19	30.38	16	0.500	0.38	3/8-18	11.250	0.81	28	12.00
26CB525	142437	184800	14.25	0.25	34.000	32.750	26.19	32.50	16	0.625	0.50	1/2-14	11.250	0.84	32	12.56
28CB525	142438	212000	14.44	0.25	36.000	34.750	28.19	34.50	16	0.625	0.50	1/2-14	11.250	0.84	34	12.69
30CB525	142439	242000	14.44	0.25	38.000	36.750	30.19	36.50	16	0.625	0.50	1/2-14	11.250	0.84	36	12.69
32CB525	142440	274000	14.44	0.25	40.000	38.750	32.19	38.50	18	0.625	0.50	1/2-14	5	0.84	38	12.69
36CB525	142441	344000	14.44	0.25	44.625	43.125	36.19	43.25	18	0.750	0.63	3/4-14	5	0.84	44	12.69
40CB525	142442	422000	14.44	0.25	48.625	47.125	40.19	47.25	20	0.750	0.63	3/4-14	9.000	0.84	48	12.69
45CB525	142443	520000	14.44	0.28	53.625	52.125	45.19	52.25	24	0.750	0.63	3/4-14	7.500	0.84	54	12.69
Size	① Part Number	② M. Torque Rating	D ₂	D ₂₅	③ G	H ₂	H ₆	H ₇	No. Size		④ O ₃	O ₄	Q (Deg)	V	No. Width	
									L (Bolt)	Size					W	Width
12CB350	142731	3010	257	5	447,7	428,6	308	429	14	10	8	3/8-18	12,857	17	24	222
14CB400	142604	4450	283	5	498,5	479,4	359	479	16	10	8	3/8-18	11,250	17	28	248
16CB500	142432	7960	346	5	596,9	571,5	411	565	8	13	10	3/8-18	22,500	21	20	305
18CB500	142433	9940	346	5	647,7	619,1	462	619	12	13	10	3/8-18	15,000	21	22	305
20CB500	142434	12100	346	5	698,5	669,9	513	670	12	13	10	3/8-18	15,000	21	24	305
22CB500	142435	14100	346	5	749,3	720,7	564	721	12	13	10	3/8-18	15,000	21	26	305
24CB500	142436	17000	346	5	800,1	771,5	614	772	16	13	10	3/8-18	11,300	21	28	305
26CB525	142437	20900	362	6	863,6	831,9	665	826	16	16	13	1/2-14	11,300	21	32	319
28CB525	142438	24000	367	6	914,4	882,7	716	876	16	16	13	1/2-14	11,300	21	34	322
30CB525	142439	27300	367	6	965,2	933,5	767	927	16	16	13	1/2-14	11,300	21	36	322
32CB525	142440	31000	367	6	1016,0	984,3	818	978	18	16	13	1/2-14	5	21	38	322
36CB525	142441	38900	367	6	1133,5	1095,4	919	1099	18	19	16	3/4-14	5	21	44	322
40CB525	142442	47700	367	6	1235,1	1197,0	1021	1200	20	19	16	3/4-14	9,000	21	48	322
45CB525	142443	58800	367	7	1362,1	1324,0	1148	1327	24	19	16	3/4-14	7,500	21	54	322
SI		Nm @ 5, 2bar	Dimensions in millimeters													

Size	Part Numbers				
	Element Assembly		Integral Drum and Hub	Spider	
	One inlet	Two inlets		One inlet	Two inlets
6CB200	142095JB	142095JG	10108	408367	408368
8CB250	142096JB	142096JG	10109	408369	408370
10CB300	142197JB	142197JG	10110	408371	408372
12CB350	142098JB	142098JG	10111	408373	408374
14CB400	142087JB	142087JG	9617	408375	408376

English ^⑥	lb	lb ft ²	lb	lb ft ²	lb	lb ft ²
	Element		Integral Drum and Hub		Spider	
6CB200	7	1	10	0.3	15	1.2
8CB250	9	2	19	0.8	19	2.3
10CB300	19	6	33	2.5	40	5.3
12CB350	26	11	53	5.4	46	8.1
14CB400	31	17	65	8.5	50	11.2

Size	Weight		Weight		Weight	
	Element		Integral Drum and Hub		Spider	
	Mass	J	Mass	J	Mass	J
6CB200	3,2	0,04	4,5	0,01	6,8	0,05
8CB250	4,1	0,08	8,6	0,03	8,6	0,10
10CB300	8,6	0,25	15	0,11	18	0,22
12CB350	12	0,46	24	0,23	21	0,34
14CB400	14	0,71	29	0,36	23	0,47

SI ^⑥	kg	kg m ²	kg	kg m ²	kg	kg m ²
-----------------	----	-------------------	----	-------------------	----	-------------------

Notes:

- ① Refers to basic part number only and does not include the rotorseal and hose. When ordering, the number of element connections must be specified.
- ② Dynamic torque shown, static torque approximately 25% greater. Torque in each application is dependent upon air pressure and speed.
- ③ Based upon minimum bores. Rotorseal and hose not included.
- ④ Refer to Rotorseal Section for mounting and dimension information.
- ⑤ $M = 0.268 (H/2 - \text{radius of bore}) + Y_1$
- ⑥ Based upon minimum bores.

Airflex® CB Clutch Application



Form CB-405

Close-Mounted Arrangement – Dimensional Data
 Sizes 6 to 14

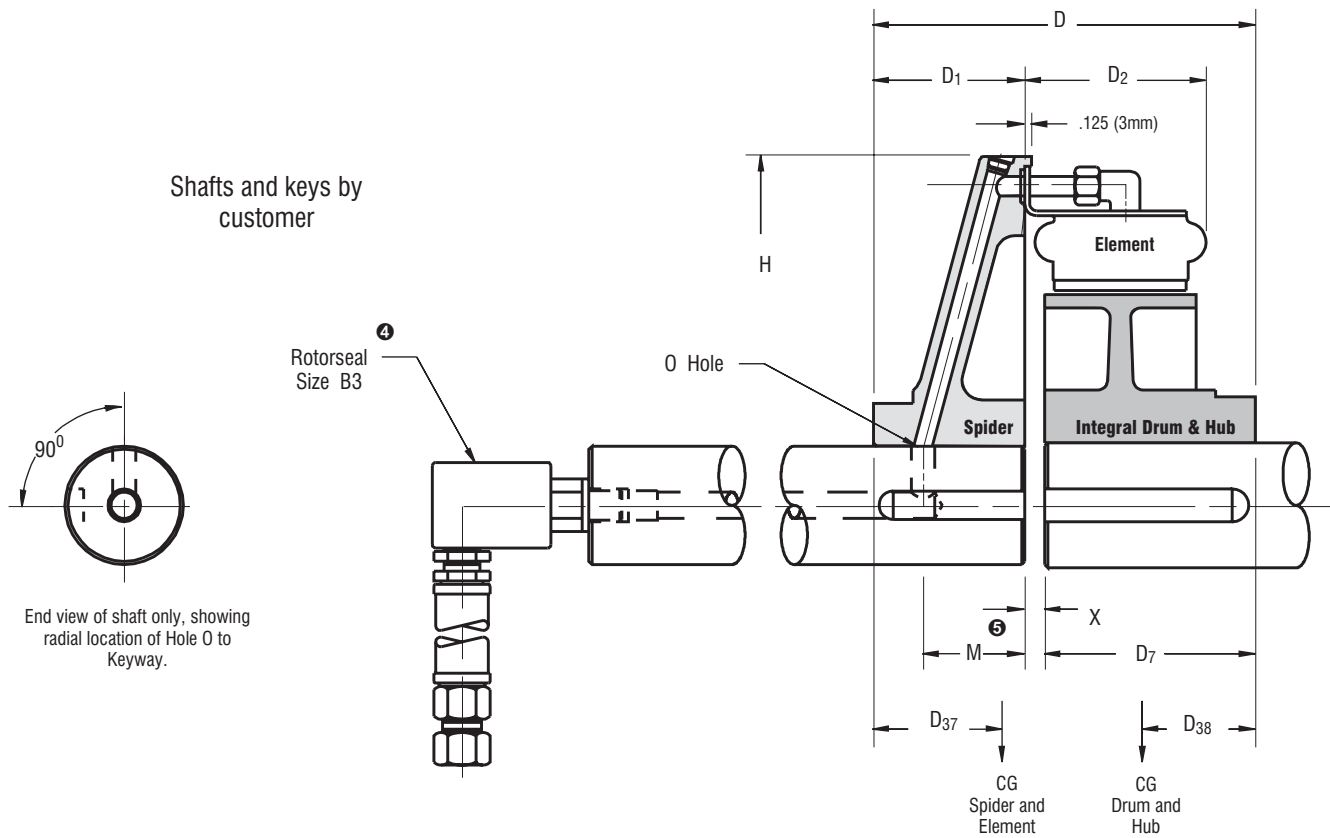

English			lb in @ 75 psi			lb ^③			Dimensions in inches							
6CB200	104119	2040	32	1.00	2.50	5.63	2.38	2.94	2.88	2.40	1.50	11.13	0.44	0.38	0.34	
8CB250	104120	4290	47	1.00	2.88	6.75	2.88	3.44	3.50	2.70	1.90	13.25	0.44	0.38	0.41	
10CB300	104121	8150	92	1.25	3.31	8.00	3.56	4.13	4.00	2.50	2.10	15.75	0.44	0.44	0.41	
12CB350	104122	13300	125	1.50	3.31	8.94	4.00	4.72	4.50	3.20	2.30	18.00	0.44	0.44	0.34	
14CB400	104123	19700	146	2.00	4.25	9.96	4.34	5.22	5.00	3.40	2.60	20.00	0.44	0.56	0.34	
Size	① Part Number	② M, Torque Rating	Total Weight	Bore Range		D	D ₁	D ₂	D ₇	D ₃₇	D ₃₈	H	O	X	Y ₁	
				Min.	Max.											
				Min.	Max.											
6CB200	104119	231	14	25	64	143	60	75	73	61	38	283	11	10	9	
8CB250	104120	485	21	25	73	171	73	87	89	69	48	337	11	10	10	
10CB300	104121	921	42	32	84	203	90	105	102	64	53	400	11	11	10	
12CB350	104122	1500	57	38	84	227	102	120	114	81	58	457	11	11	9	
14CB400	104123	2230	66	51	108	253	110	133	127	86	66	508	11	14	9	

SI			Nm @ 5.2 bar			kg ^③			Dimensions in millimeters							
----	--	--	--------------	--	--	-----------------	--	--	---------------------------	--	--	--	--	--	--	--

Size	Part Numbers					
	Element Assembly		Drum	Drum Hub	Spider	
	One inlet	Two inlets			One inlet	Two inlets
6CB200	142095JB	142095JG	407044	408414	408367	408368
8CB250	142096JB	142096JG	407046	406900	408369	408370
10CB300	142197JB	142197JG	407048	406902	408371	408372
12CB350	142098JB	142098JG	407050	406902	408373	408374
14CB400	142087JB	142087JG	407052	406904	408375	408376

English ^⑥	lb	lb ft ²	lb	lb ft ²	lb	lb ft ²	lb	lb ft ²
6CB200	7	1	5.5	0.3	8	0.1	15	1.2
8CB250	9	2	12.5	1.1	11	0.3	19	2.3
10CB300	19	6	19	2.7	22	0.8	40	5.3
12CB350	26	11	30	5.9	22	0.8	46	8.1
14CB400	31	17	38	10.5	54	3.2	50	11.2

Size	Weight		Weight		Weight		Weight	
	Element		Drum		Drum Hub		Spider	
	Mass	J	Mass	J	Mass	J	Mass	J
6CB200	3,2	0,04	2,5	0,01	3,6	0,00	6,8	0,05
8CB250	4,1	0,08	5,7	0,05	5,0	0,01	8,6	0,10
10CB300	8,6	0,25	8,6	0,11	10,0	0,03	18	0,22
12CB350	12	0,46	14	0,25	10,0	0,03	21	0,34
14CB400	14	0,71	17	0,44	24	0,13	23	0,47

SI ^⑥	Kg	kg m ²	Kg	kg m ²	Kg	kg m ²	Kg	kg m ²
-----------------	----	-------------------	----	-------------------	----	-------------------	----	-------------------

Notes:

- ① Refers to basic part number only and does not include the rotorseal and hose. When ordering, the number of element connections must be specified.
- ② Dynamic torque shown, static torque approximately 25% greater. Torque in each application is dependent upon air pressure and speed.
- ③ Based upon minimum bores. Rotorseal and hose not included.
- ④ Refer to Rotorseal Section for mounting and dimension information.
- ⑤ $M = 0.268 (H/2 - \text{radius of bore}) + Y_1$
- ⑥ Based upon minimum bores.

Airflex[®] CB Clutch Application



Form CB-404

Gap-Mounted Arrangement – Dimensional Data
 Sizes 6 to 14

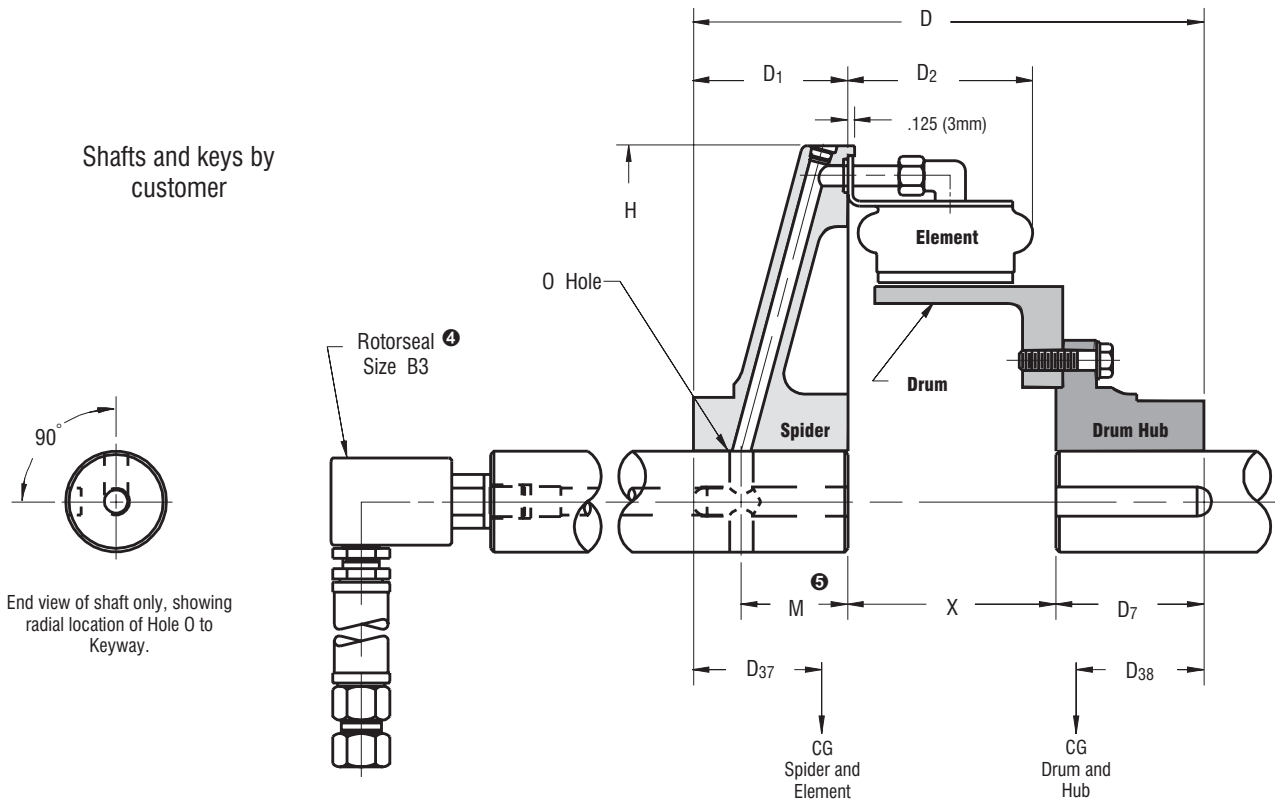

English		lb in @ 75 psi	lb [ⓐ]	Dimensions in inches											
6CB200	104114	2040	35.5	1.00	2.50	8.38	2.38	2.94	2.75	2.40	2.40	11.13	0.44	3.25	0.34
8CB250	104115	4290	51.5	1.00	2.88	9.38	2.88	3.44	2.75	2.70	2.70	13.25	0.44	3.75	0.41
10CB300	104116	8150	100	1.25	3.31	11.19	3.56	4.13	3.25	2.50	3.20	15.75	0.44	4.38	0.41
12CB350	104117	13300	124	1.50	3.31	12.25	4.00	4.72	3.25	3.20	3.50	18.00	0.44	5.00	0.34
14CB400	104118	19700	173	2.00	4.25	14.84	4.34	5.22	5.00	3.40	4.30	20.00	0.44	5.50	0.34
Size	Part Number ^①	Mr Torque Rating ^②	Weight Mass	Bore Range		D	D ₁	D ₂	D ₇	D ₃₇	D ₃₈	H	O	X	Y ₁
				min	max										
6CB200	104114	231	16	25	64	213	60	75	70	61	61	283	11	83	9
8CB250	104115	485	23	25	73	238	73	87	70	69	69	337	11	95	10
10CB300	104116	921	45	32	84	284	90	105	83	64	81	400	11	111	10
12CB350	104117	1500	56	38	84	311	102	120	83	81	89	457	11	127	9
14CB400	104118	2230	78	51	108	377	110	133	127	86	109	508	11	140	9
SI		Nm @ 5,2 bar	Kg [ⓐ]	Dimensions in millimeters											

Airflex® CB Clutch Application



Form CB-406

Gap-Mounted Arrangement – Technical Data
Sizes 16 to 45

Size	Part Numbers				
	Element Assembly		Drum	Drum Hub	Spider
	One inlet	Four inlets			
16CB500	142211KM	142211KP	407053	406906	408276
18CB500	142264KM	142264KP	408285	406908	408277
20CB500	142265KM	142265KP	407055	406910	408278
22CB500	142266KM	142266KP	408287	406912	408279
24CB500	142267KM	142267KP	407057	406914	408280
26CB525	142268KM	142268KP	408289	406916	408281

Size	Part Numbers				
	Element Assembly		Drum	Drum Hub	Spider
	One inlet	Four inlets			
28CB525	142269KM	142269KP	407059	406918	408282
30CB525	142270KM	142270KP	408343	406920	407096
32CB525	142271KM	142271KP	407061	406922	407097
36CB525	142272KM	142272KP	407063	406924	407098
40CB525	142273KM	142273KP	407065	406926	407099
45CB525	142081KM	142081KP	407067	406928	502369

English ⑦	lb	lb ft ²	lb	lb ft ²	lb	lb ft ²	lb	lb ft ²
16CB500	74	52	50	19	74	6.6	146	53
18CB500	81	70	67	31	83	9	152	63
20CB500	88	90	72	43	97	16	183	91
22CB500	95	114	79	58	133	25	227	123
24CB500	102	142	93	80	142	33	257	150
26CB525	133	210	108	110	164	43	298	220
28CB525	140	252	117	140	172	55	337	270
30CB525	148	303	140	192	213	69	341	390
32CB525	157	359	160	252	234	97	392	453
36CB525	178	510	160	319	319	157	505	710
40CB525	201	730	209	523	344	214	464	774
45CB525	262	1115	237	758	491	379	1294	1887

Size	Weight		Weight		Weight		Weight	
	Element Assembly		Drum		Drum Hub		Spider	
	Mass	J	Mass	J	Mass	J	Mass	J
16CB500	34	2,18	23	0,80	34	0,28	66	2,23
18CB500	37	2,94	30	1,30	38	0,38	69	2,65
20CB500	40	3,78	33	1,81	44	0,67	83	3,82
22CB500	43	4,79	36	2,44	60	1,05	103	5,17
24CB500	46	5,96	42	3,36	64	1,39	116	6,30
26CB525	60	8,82	49	4,62	74	1,81	135	9,24
28CB525	63	10,58	53	5,88	78	2,31	153	11,34
30CB525	67	12,73	63	8,06	96	2,90	154	16,38
32CB525	71	15,08	72	10,58	106	4,07	178	19,03
36CB525	81	21,42	72	13,40	145	6,59	229	29,82
40CB525	91	30,66	95	21,97	156	8,99	210	32,51
45CB525	119	46,83	107	31,84	222	15,92	586	79,25

SI ⑦	kg	kg m ²	kg	kg m ²	kg	kg m ²	kg	kg m ²
------	----	-------------------	----	-------------------	----	-------------------	----	-------------------

Notes:

- ① Refers to basic part number only and does not include the rotor seal and hose. When ordering, the number and type of element connections must be specified.
- ② Dynamic torque shown, static torque approximately 25% greater. Torque in each application is dependent upon air pressure and speed.
- ③ Based upon minimum bores. Rotor seal and hose not included.
- ④ American National Pipe Thread
- ⑤ Refer to Rotor Seal Section for mounting and dimension information.
- ⑥ Refer to CB Spider Piping and Configuration catalog page for other sizes.
- ⑦ Based upon minimum bores.

Airflex® CB Clutch Application



Form CB-406

Gap-Mounted Arrangement – Dimensional Data
 Sizes 16 to 45

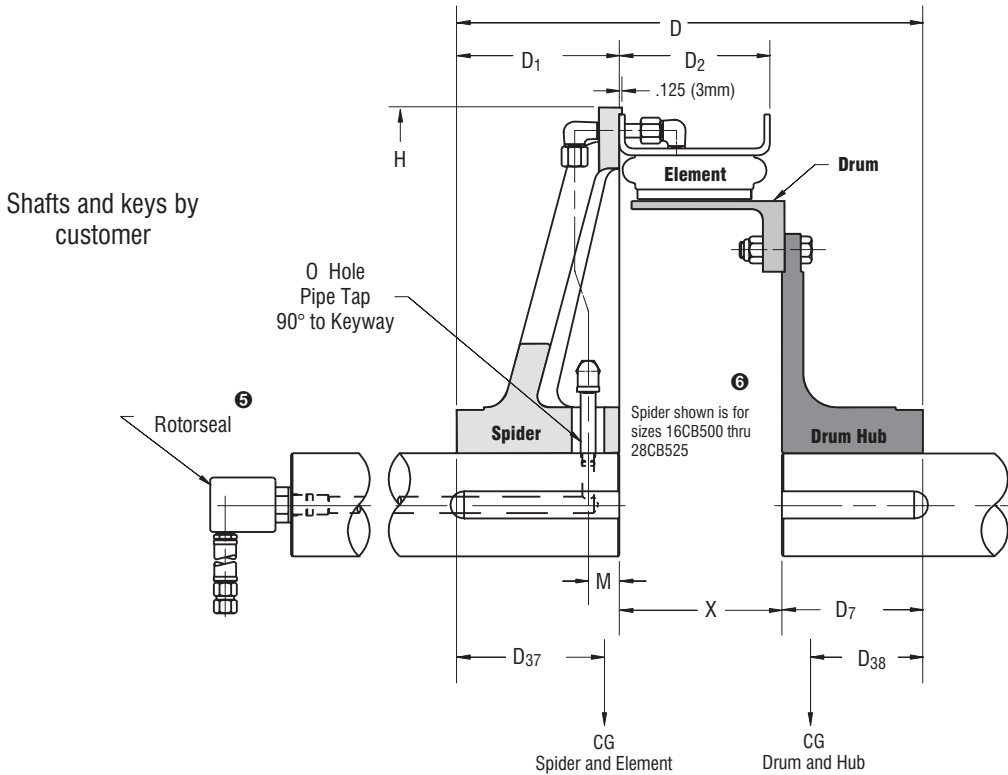

English		lb in @ 75 psi	lb ③	Dimensions in inches													
Size	Part Number	M, ② Torque Rating	Rotorseal Size	Weight Mass	min	max	D	D ₁	D ₂	D ₇	D ₃₇	D ₃₈	H	M ④	O	X	
					Bore Range												
					min	max											
16CB500	104124	35200	C2	344	2.00	4.88	18.31	5.50	6.63	5.75	5.20	5.30	24.00	1.44	3/8-18	7.06	
18CB500	104125	44000	C2	383	2.25	5.00	18.31	5.50	6.63	5.75	5.30	5.40	26.00	1.44	3/8-18	7.06	
20CB500	104126	53600	C2	440	2.50	5.00	18.31	5.50	6.63	5.75	5.30	5.50	28.00	1.44	3/8-18	7.06	
22CB500	104127	62300	C2	534	2.75	5.69	19.56	6.00	6.63	6.50	5.40	5.80	30.00	1.44	3/8-18	7.06	
24CB500	104128	75000	C2	594	2.75	5.69	20.06	6.50	6.63	6.50	5.60	5.90	32.00	1.44	3/8-18	7.06	
26CB525	104129	92400	C2	703	2.75	5.69	20.50	6.50	6.94	6.50	5.90	6.00	34.63	1.44	3/8-18	7.50	
28CB525	104130	106000	C2	766	2.75	5.69	21.50	7.50	6.94	6.50	6.60	6.00	36.63	1.44	3/8-18	7.50	
30CB525	104131	121000	C2	842	3.00	6.31	23.00	7.50	6.94	8.00	6.80	7.20	38.63	1.44	3/8-18	7.50	
32CB525	104132	137000	C2	943	3.00	6.06	23.00	7.50	6.94	8.00	6.60	7.40	40.63	1.44	3/8-18	7.50	
36CB525	104133	172000	C2	1162	4.00	7.00	25.00	8.50	6.94	9.00	7.10	7.70	45.25	1.44	1/2-14	7.50	
40CB525	104134	211000	3/4 RH	1218	4.00	7.00	25.00	8.50	6.94	9.00	7.60	8.10	49.25	1.44	1/2-14	7.50	
45CB525	104135	260000	3/4 RH	2284	4.38	9.88	28.50	11.00	6.94	10.00	8.80	8.30	54.25	6.00	1/2-14	7.50	

SI		Nm @ 5.2 bar	kg ③	Dimensions in millimeters													
Size	Part Number	M, ② Torque Rating	Rotorseal Size	Weight Mass	min	max	D	D ₁	D ₂	D ₇	D ₃₇	D ₃₈	H	M ④	O	X	
					Bore Range												
					min	max											
16CB500	104124	3980	C2	156	51	124	465	140	168	146	132	135	610	37	3/8-18	179	
18CB500	104125	4970	C2	173	57	127	465	140	168	146	135	137	660	37	3/8-18	179	
20CB500	104126	6060	C2	199	64	127	465	140	168	146	135	140	711	37	3/8-18	179	
22CB500	104127	7040	C2	242	70	144	497	152	168	165	137	147	762	37	3/8-18	179	
24CB500	104128	8480	C2	269	70	144	510	165	168	165	142	150	813	37	3/8-18	179	
26CB525	104129	10400	C2	318	70	144	521	165	176	165	150	152	879	37	3/8-18	191	
28CB525	104130	12000	C2	347	70	144	546	191	176	165	168	152	930	37	3/8-18	191	
30CB525	104131	13700	C2	381	76	160	584	191	176	203	173	183	981	37	3/8-18	191	
32CB525	104132	15500	C2	427	76	154	584	191	176	203	168	188	1032	37	3/8-18	191	
36CB525	104133	19400	C2	526	102	178	635	216	176	229	180	196	1149	37	1/2-14	191	
40CB525	104134	23800	3/4 RH	552	102	178	635	216	176	229	193	206	1251	37	1/2-14	191	
45CB525	104135	29400	3/4 RH	1035	111	251	724	279	176	254	224	211	1378	152	1/2-14	191	

Airflex® CB Clutch Application



Form CB-407

Gap-Mounted Arrangement – Technical Data
 Sizes Dual 12 to Dual 45

Size	Part Number		Drum	Drum Hub	Spider
	Element Assembly				
	Two inlets	Four inlets			
12CB350	142731DA		411860	406902	408374
14CB400	142604DA		411861	406904	408376
16CB500	142432DA	142432DK	411862	406906	408276
18CB500	142433DA	142433DK	411863	406908	408277
20CB500	142434DA	142434DK	411864	406910	408278
22CB500	142435DA	142435DK	411865	406912	408279
24CB500	142436DA	142436DK	411866	406914	408280

Size	Part Number		Drum	Drum Hub	Spider
	Element Assembly				
	Two inlets	Four inlets			
26CB525	142437DA	142437DK	411867	406916	408281
28CB525	142438DA	142438DK	411868	406918	408282
30CB525	142439DA	142439DK	411869	406920	407096
32CB525	142440DA	142440DK	411870	406922	407097
36CB525	142441DA	142441DK	411871	406924	407098
40CB525	142442DA	142442DK	411872	406926	407099
45CB525	142443DA	142443DK	411873	406928	502369

English ^⑨	lb	lb ft ²	lb	lb ft ²	lb	lb ft ²	lb	lb ft ²
12CB350	58	24	61	13	22	0.8	46	8.1
14CB400	75	42	83	24	54	3.2	50	11.2
16CB500	151	106	109	43	74	6.6	146	53
18CB500	166	144	126	63	83	9	152	63
20CB500	180	185	139	87	97	16	183	91
22CB500	194	233	152	117	133	25	227	123
24CB500	209	292	173	156	142	33	257	150
26CB525	272	432	198	211	164	43	298	220
28CB525	286	517	216	268	172	55	337	270
30CB525	302	621	237	337	213	69	341	390
32CB525	321	736	254	413	234	97	392	453
36CB525	366	1052	287	597	319	157	505	710
40CB525	413	1502	327	840	344	214	464	774
45CB525	537	2293	369	1212	491	379	1294	1887

Size	Weight		Weight		Weight		Weight	
	Element Assembly		Drum		Drum Hub		Spider	
	Mass	J	Mass	J	Mass	J	Mass	J
12CB350	26	1,01	28	0,55	10	0,03	21	0,34
14CB400	34	1,76	38	1,01	24	0,13	23	0,47
16CB500	68	4,45	49	1,81	34	0,28	66	2,23
18CB500	75	6,05	57	2,65	38	0,38	69	2,65
20CB500	82	7,77	63	3,65	44	0,67	83	3,82
22CB500	88	9,79	69	4,91	60	1,05	103	5,17
24CB500	95	12,26	78	6,55	64	1,39	116	6,30
26CB525	123	18,14	90	8,86	74	1,81	135	9,24
28CB525	130	21,71	98	11,26	78	2,31	153	11,34
30CB525	137	26,08	107	14,15	96	2,90	154	16,38
32CB525	145	30,91	115	17,35	106	4,07	178	19,03
36CB525	166	44,18	130	25,07	145	6,59	229	29,82
40CB525	187	63,08	148	35,28	156	8,99	210	32,51
45CB525	243	96,31	167	50,90	222	15,92	586	79,25

SI ^⑨	kg	kg m ²	kg	kg m ²	kg	kg m ²	kg	kg m ²
-----------------	----	-------------------	----	-------------------	----	-------------------	----	-------------------

Notes:

- ① Refers to basic part number only and does not include the rotor seal and hose. When ordering, the number and type of element connections must be specified.
- ② Dynamic torque shown, static torque approximately 25% greater. Torque in each application is dependent upon air pressure and speed.
- ③ Based upon minimum bores. Rotor seal and hose not included.
- ④ $M (in) = 0.268 (H/2 - \text{radius of bore}) + 0.34$
 $M (mm) = 0.268 (H/2 - \text{radius of bore}) + 8,7$
- ⑤ American National Pipe Thread
- ⑥ Pipe tap not required. Thru hole diameter 0.44 in (11 mm).
- ⑦ Refer to Rotor Seal Section for mounting and dimension information.
- ⑧ Refer to CB Spider Piping and Configuration catalog page for other sizes.
- ⑨ Based upon minimum bores.

Airflex[®] CB Clutch Application



Form CB-407

Gap-Mounted Arrangement – Dimensional Data
 Sizes Dual 12 to Dual 45

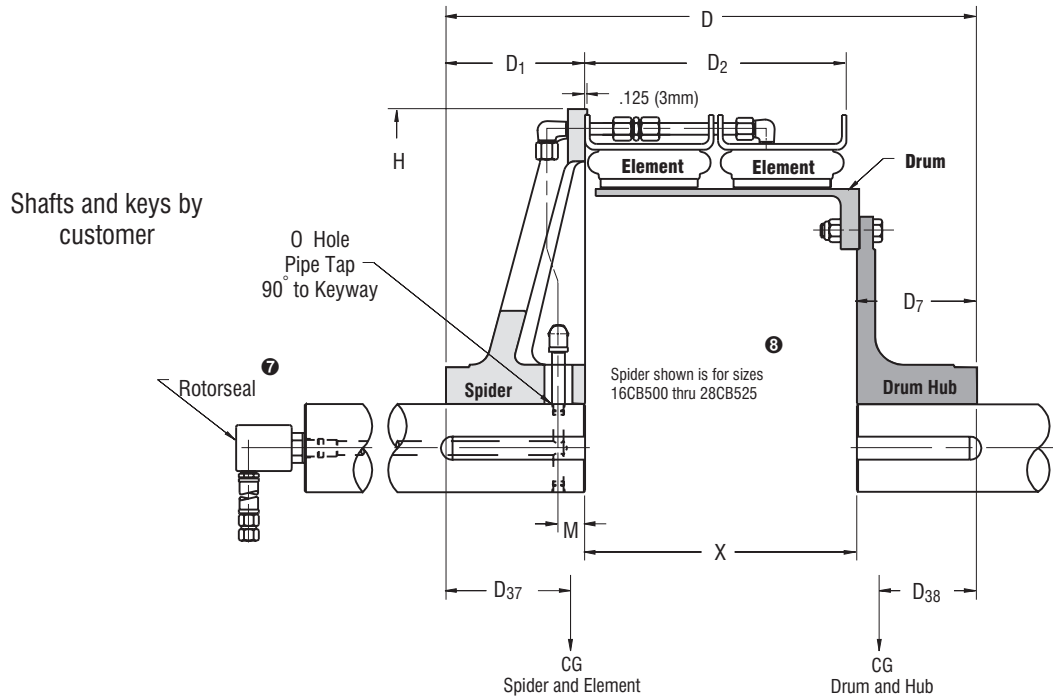

English	Part Number	lb in @ 75 psi	Rotorseal Size	Weight lb ③	Dimensions in inches											
Size	① Part Number	M, Torque Rating ②	Rotorseal Size	Weight Mass	Bore Range		D	D ₁	D ₂	D ₇	D ₃₇	D ₃₈	H	M	⑤ O	X
					min	max										
12CB350	105480	26600	C2	187	1.50	2.63	17.75	4.00	10.13	3.25	6.20	5.80	18.00	④	⑥	10.50
14CB400	105481	39400	C2	262	2.00	3.56	20.84	4.34	11.13	5.00	7.40	6.70	20.00	④	⑥	11.50
16CB500	105482	70400	C2	480	2.00	4.13	25.25	5.50	13.63	5.75	8.00	8.00	24.00	1.44	3/8-18	14.00
18CB500	105483	88000	C2	527	2.25	4.38	25.25	5.50	13.63	5.75	8.10	8.00	26.00	1.44	3/8-18	14.00
20CB500	105522	107200	C2	599	2.50	3.81	25.25	5.50	13.63	5.75	7.70	8.10	28.00	1.44	3/8-18	14.00
22CB500	105484	124600	C2	706	2.75	4.50	26.50	6.00	13.63	6.50	7.90	8.30	30.00	1.44	3/8-18	14.00
24CB500	105485	150000	C2	781	2.75	4.50	27.00	6.50	13.63	6.50	8.10	8.30	32.00	1.44	3/8-18	14.00
26CB525	105486	184800	3/4 RH	932	2.75	4.50	27.63	6.50	14.25	6.50	8.70	8.40	34.63	1.44	3/8-18	14.63
28CB525	105487	212000	3/4 RH	1011	2.75	3.81	28.75	7.50	14.44	6.50	9.30	8.70	36.63	1.44	3/8-18	14.75
30CB525	105488	242000	3/4 RH	1093	3.00	4.50	30.25	7.50	14.44	8.00	9.50	9.50	38.63	1.44	3/8-18	14.75
32CB525	105489	274000	3/4 RH	1201	3.00	4.00	30.25	7.50	14.44	8.00	9.30	9.70	40.63	1.44	3/8-18	14.75
36CB525	105490	344000	3/4 RH	1477	4.00	5.75	32.25	8.50	14.44	9.00	9.70	9.90	45.25	1.44	1/2-14	14.75
40CB525	105491	422000	1 RH	1548	4.00	4.88	32.25	8.50	14.44	9.00	10.40	10.10	49.25	1.44	1/2-14	14.75
45CB525	105492	520000	1 RH	2691	4.38	8.00	35.75	11.00	14.44	10.00	10.70	10.10	54.25	6.00	1/2-14	14.75
12CB350	105480	3010	C2	85	38	67	451	102	257	83	157	147	457	④	⑥	267
14CB400	105481	4450	C2	119	51	90	529	110	283	127	188	170	508	④	⑥	292
16CB500	105482	7960	C2	217	51	105	641	140	346	146	203	203	610	37	3/8-18	356
18CB500	105483	9940	C2	239	57	111	641	140	346	146	206	203	660	37	3/8-18	356
20CB500	105522	12100	C2	271	64	97	641	140	346	146	196	206	711	37	3/8-18	356
22CB500	105484	14100	C2	320	70	114	673	152	346	165	201	211	762	37	3/8-18	356
24CB500	105485	17000	C2	354	70	114	686	165	346	165	206	211	813	37	3/8-18	356
26CB525	105486	20900	3/4 RH	422	70	114	702	165	362	165	221	213	879	37	3/8-18	372
28CB525	105487	24000	3/4 RH	458	70	97	730	191	367	165	236	221	930	37	3/8-18	375
30CB525	105488	27300	3/4 RH	495	76	114	768	191	367	203	241	241	981	37	3/8-18	375
32CB525	105489	31000	3/4 RH	544	76	102	768	191	367	203	236	246	1032	37	3/8-18	375
36CB525	105490	38900	3/4 RH	669	102	146	819	216	367	229	246	251	1149	37	1/2-14	375
40CB525	105491	47700	1 RH	701	102	124	819	216	367	229	264	257	1251	37	1/2-14	375
45CB525	105492	58800	1 RH	1219	111	203	908	279	367	254	272	257	1378	152	1/2-14	375
SI		Nm @ 5.2 bar		Kg ③	Dimensions in millimeters											

Size	Part Numbers			
	Element Assembly		Drum	Spider
	Two inlets	Four inlets		
12CB350	142098JB	142098JG ^⑩	411778	408373 [●]
14CB400	142087JB	142087JG ^⑩	411779	408375 [■]
16CB500	142211KM	142211KP	411780	408276
18CB500	142264KM	142264KP	411781	408277
20CB500	142265KM	142265KP	411782	408278
22CB500	142266KM	142266KP	411783	408279
24CB500	142267KM	142267KP	411784	408280

Size	Part Numbers			
	Element Assembly		Drum	Spider
	Two inlets	Four inlets		
26CB525	142268KM	142268KP	411786	408281
28CB525	142269KM	142269KP	411785	408282
30CB525	142270KM	142270KP	411787	407096
32CB525	142271KM	142271KP	411788	407097
36CB525	142272KM	142272KP	411789	407098
40CB525	142273KM	142273KP	411790	407099
45CB525	142081KM	142081KP	411791	502369

English [▲]	lb	lb ft ²	lb	lb ft ²	lb	lb ft ²
12CB350	30	12	26	6.4	46	8.1
14CB400	35	21	45	18	50	11.2
16CB500	74	52	63	31	146	53
18CB500	81	70	72	44	152	63
20CB500	88	90	126	102	183	91
22CB500	95	114	115	103	227	123
24CB500	102	142	130	139	257	150
26CB525	133	210	144	178	298	220
28CB525	140	252	143	200	337	270
30CB525	148	303	166	271	341	390
32CB525	157	359	177	327	392	453
36CB525	178	510	199	462	505	710
40CB525	201	730	220	631	464	774
45CB525	262	1115	248	893	1294	1887

Size	Weight	Wk ²	Weight	Wk ²	Weight	Wk ²
	Element		Drum		Spider	

SI [▲]	kg	kg m ²	kg	kg m ²	kg	kg m ²
12CB350	14	0,50	12	0,27	21	0,34
14CB400	16	0,88	20	0,76	23	0,47
16CB500	34	2,18	29	1,30	66	2,23
18CB500	37	2,94	33	1,85	69	2,65
20CB500	40	3,78	57	4,28	83	3,82
22CB500	43	4,79	52	4,33	103	5,17
24CB500	46	5,96	59	5,84	116	6,30
26CB525	60	8,82	65	7,48	135	9,24
28CB525	63	10,58	65	8,40	153	11,34
30CB525	67	12,73	75	11,38	154	16,38
32CB525	71	15,08	80	13,73	178	19,03
36CB525	81	21,42	90	19,40	229	29,82
40CB525	91	30,66	100	26,50	210	32,51
45CB525	119	46,83	112	37,51	586	79,25

Size	Mass	J	Mass	J	Mass	J
	Element		Drum		Spider	

Notes:

- ^① Refers to basic part number only and does not include the rotor seal and hose. Element sizes 12 and 14 have either one or two inlets. All other sizes have either one or four air inlets.
- ^② Dynamic torque shown, static torque approximately 25% greater. Torque in each application is dependent upon air pressure and speed.
- ^③ Based upon minimum bores. Rotor seal and hose not included.
- ^④ Drum flange tolerance +0.000/-0.003 in (+0,00/-0,08 mm).
- ^⑤ $M (in) = 0.268 (H/2 - \text{radius of bore}) + 0.34$
 $M (mm) = 0.268 (H/2 - \text{radius of bore}) + 8,7$
- ^⑥ American National Pipe Thread
- ^⑦ Pipe tap not required. Thru hole diameter 0.44 in (11 mm).
- ^⑧ Refer to Rotor seal Section for mounting and dimension information.
- ^⑨ Refer to CB Spider Piping and Configuration catalog page for other sizes.
- ^⑩ Part number for two inlets.
- [●] Part number for one inlet. Part number for two inlets - 408374.
- [■] Part number for one inlet. Part number for two inlets - 408376.
- [▲] Based upon minimum bore.

Airflex® CB Clutch Application



Form CB-408

Engine Mounted Arrangement – Dimensional Data
 Sizes 12 to 45

Shafts and keys
 by customer

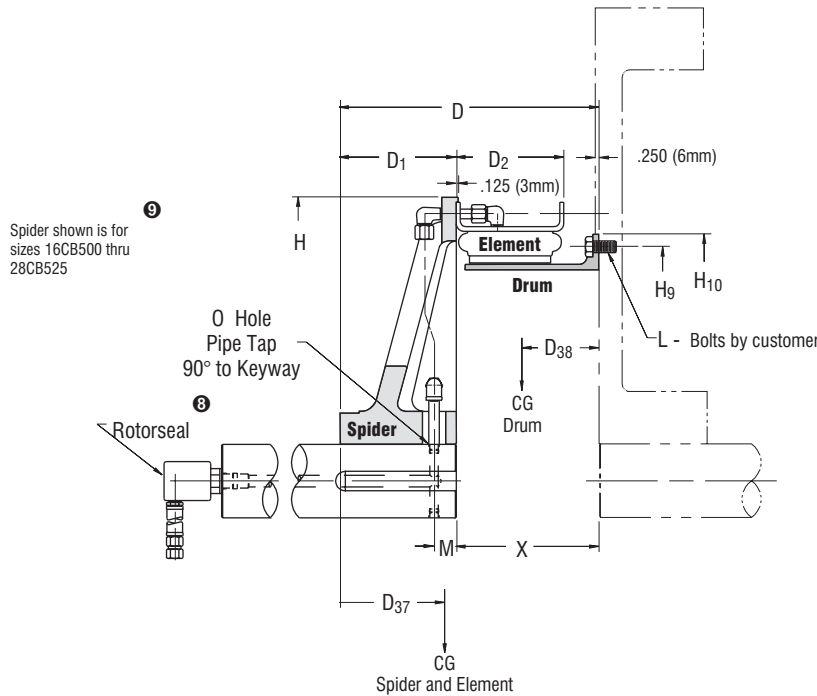

English		lb/in @ 75 psi	lb ③	Dimensions in inches																	
12CB350	104137	13300	B2	102	1.50	3.31	10.56	4.00	4.72	3.20	2.20	18.00	13.125	13.875	8	0.375	1.00	⑤	⑦	6.56	
14CB400	104140	19700	B2	130	2.00	4.25	11.53	4.34	5.22	3.40	2.00	20.00	17.250	18.375	8	0.500	1.25	⑤	⑦	7.19	
16CB500	104142	35200	C2	283	2.00	4.88	14.19	5.50	6.63	5.20	2.60	24.00	19.250	20.375	8	0.500	1.25	1.44	3/8-18	8.69	
18CB500	104144	44000	C2	305	2.25	5.00	14.19	5.50	6.63	5.30	2.60	26.00	21.375	22.500	6	0.625	1.25	1.44	3/8-18	8.69	
20CB500	104145	53600	C2	397	2.50	5.00	14.19	5.50	6.63	5.30	2.30	28.00	25.250	26.500	12	0.625	1.25	1.44	3/8-18	8.69	
22CB500	104147	62300	C2	437	2.75	5.69	14.69	6.00	6.63	5.40	2.60	30.00	25.250	26.500	12	0.625	1.25	1.44	3/8-18	8.69	
24CB500	104148	75000	C2	489	2.75	5.69	15.19	6.50	6.63	5.60	2.60	32.00	27.250	28.875	12	0.750	1.25	1.44	3/8-18	8.69	
26CB525	104149	92400	C2	575	2.75	5.69	15.69	6.50	6.94	5.90	2.80	34.63	29.250	30.750	12	0.750	1.50	1.44	3/8-18	9.19	
28CB525	104150	106000	C2	620	2.75	5.69	16.69	7.50	6.94	6.60	3.00	36.63	30.250	31.875	12	0.750	1.50	1.44	3/8-18	9.19	
30CB525	104151	121000	C2	655	3.00	6.31	16.69	7.50	6.94	6.80	2.80	38.63	33.000	34.750	12	0.750	1.50	1.44	3/8-18	9.19	
32CB525	105472	137000	C2	726	3.00	6.06	16.69	7.50	6.94	6.60	2.80	40.63	35.250	36.750	14	0.750	1.50	1.44	3/8-18	9.19	
36CB525	105473	172000	C2	882	4.00	7.00	17.69	8.50	6.94	7.10	2.80	45.25	39.250	40.750	16	0.750	1.50	1.44	1/2-14	9.19	
40CB525	104153	211000	3/4 RH	885	4.00	7.00	17.69	8.50	6.94	7.60	2.80	49.25	43.250	44.750	16	0.750	1.50	1.44	1/2-14	9.19	
45CB525	105474	260000	3/4 RH	1804	4.38	9.88	20.19	11.00	6.94	8.80	2.90	54.25	48.250	49.750	16	0.750	1.50	6.00	1/2-14	9.19	
Size	Part Number ①	M, Torque Rating ②	Rotorseal Size	Weight Mass	Spider Bore		D	D ₁	D ₂	D ₃₇	D ₃₈	H	H ₉	H ₁₀ ③	L (Bolt)			M	O	X	
					min	max									No.	Dia.	Length				
					min	max									No.	Dia.	Length				
12CB350	104137	1500	B2	46	38	84	268	102	120	81	56	457	333,4	352,4	8	10	25	⑤	⑦	167	
14CB400	104140	2230	B2	59	51	108	293	110	133	86	51	508	438,2	466,7	8	13	32	⑤	⑦	183	
16CB500	104142	3980	C2	128	51	124	360	140	168	132	66	610	489,0	517,5	8	13	32	37	3/8-18	221	
18CB500	104144	4970	C2	138	57	127	360	140	168	135	66	660	542,9	571,5	6	16	32	37	3/8-18	221	
20CB500	104145	6060	C2	180	64	127	360	140	168	135	58	711	641,4	673,1	12	16	32	37	3/8-18	221	
22CB500	104147	7040	C2	198	70	144	373	152	168	137	66	762	641,4	673,1	12	16	32	37	3/8-18	221	
24CB500	104148	8480	C2	222	70	144	386	165	168	142	66	813	692,2	733,4	12	19	32	37	3/8-18	221	
26CB525	104149	10400	C2	260	70	144	398	165	176	150	71	879	743,0	781,1	12	19	38	37	3/8-18	233	
28CB525	104150	12000	C2	281	70	144	424	191	176	168	76	930	768,4	809,6	12	19	38	37	3/8-18	233	
30CB525	104151	13700	C2	297	76	160	424	191	176	173	71	981	838,2	882,7	12	19	38	37	1/2-14	233	
32CB525	105472	15500	C2	329	76	154	424	191	176	168	71	1032	895,4	933,5	14	19	38	37	1/2-14	233	
36CB525	105473	19400	C2	400	102	178	449	216	176	180	71	1149	997,0	1035,1	16	19	38	37	1/2-14	233	
40CB525	104153	23800	3/4 RH	401	102	178	449	216	176	193	71	1251	1098,6	1136,7	16	19	38	37	1/2-14	233	
45CB525	105474	29400	3/4 RH	817	111	251	513	279	176	224	74	1378	1225,6	1263,7	16	19	38	152	1/2-14	233	
SI		Nm @ 5,2 bar		kg ④	Dimensions in millimeters																

Size	Part Numbers			Drum	Spider
	Element Assembly		Four inlets		
	Two inlets				
12CB350	142731DA			408648	408374
14CB400	142604DA			411707	408376
16CB500	142432DA		142432DK	408682	408276
18CB500	142433DA		142433DK	410523	408277
20CB500	142434DA		142434DK	404605	408278
22CB500	142435DA		142435DK	406030	408279
24CB500	142436DA		142436DK	402145	408280
26CB525	142437DA		142437DK	411453	408281
28CB525	142438DA		142438DK	404942	408282

Size	English Units					
	Element Ass'y		Drum		Spider	
	Weight lb	Wk ² lb ft ²	Weight lb	Wk ² lb ft ²	Weight lb	Wk ² lb ft ²
12CB350	58	24	100	28	46	8.1
14CB400	75	42	103	47	50	11.2
16CB500	151	106	182	103	146	53
18CB500	166	144	201	126	152	63
20CB500	180	185	191	144	183	91
22CB500	194	233	186	159	227	123
24CB500	209	292	208	212	257	150
26CB525	272	432	234	278	298	220
28CB525	286	517	240	326	337	270

Size	SI Units					
	Element Ass'y		Drum		Spider	
	Mass kg	J kg m ²	Mass kg	J kg m ²	Mass kg	J kg m ²
12CB350	26	1,01	45	1,18	21	0,34
14CB400	34	1,76	47	1,97	23	0,47
16CB500	68	4,45	82	4,33	66	2,23
18CB500	75	6,05	91	5,29	69	2,65
20CB500	82	7,77	87	6,05	83	3,82
22CB500	88	9,79	84	6,68	103	5,17
24CB500	95	12,26	94	8,90	116	6,30
26CB525	123	18,14	106	11,68	135	9,24
28CB525	130	21,71	109	13,69	153	11,34

Notes:

- ① Refers to basic part number only and does not include the rotorseal and hose. Element sizes 12 and 14 have two inlets. All other sizes have either two or four air inlets.
- ② Dynamic torque shown, static torque approximately 25% greater. Torque in each application is dependent upon air pressure and speed.
- ③ Based upon minimum bores. Rotorseal and hose not included.
- ④ Drum flange tolerance +0.000/-0.003 in (+0,00/-0,08 mm).
- ⑤ $M (in) = 0.268 (H/2 - \text{radius of bore}) + 0.34$
 $M (mm) = 0,268 (H/2 - \text{radius of bore}) + 8,7$
- ⑥ American National Pipe Thread
- ⑦ Pipe tap not required. Thru hole diameter 0.44 in (11 mm).
- ⑧ Refer to Rotorseal Section for mounting and dimension information.
- ⑨ Refer to CB Spider Piping and Configuration catalog page for other sizes.
- ⑩ Based upon minimum bores.

Airflex® CB Clutch Application



Form CB427

Engine Mounted Arrangements – Dimensional Data
 Sizes Dual 12 to Dual 28

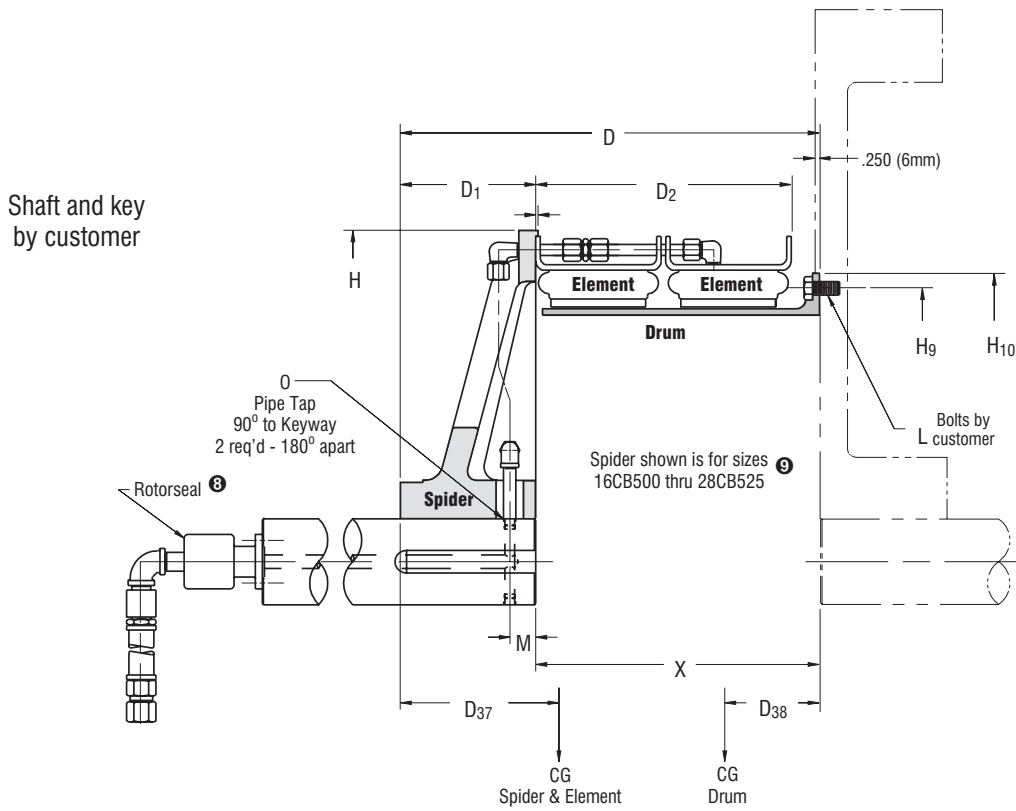

English		lb in @ 75 psi	lb [ⓐ]	Dimensions in inches																	
Size	Part No.	M, [ⓑ] Dynamic Torque Rating	Rotor seal Size	Weight Mass	min Spider Bore	max	D	D ₁	D ₂	D ₃₇	D ₃₈	H	H ₉	H ₁₀	[Ⓓ]	No.	Dia.	Length	M	O	X
					min	max										No.	Dia.	Length			
12CB350	105500	3010	C2	92	38	67	422	102	257	157	112	457	438,2	466,7	8	13	38		ⓐ	ⓑ	321
14CB400	105501	4450	C2	103	51	90	455	110	283	188	91	508	542,9	571,5	6	16	44		ⓐ	ⓑ	344
16CB500	105502	7960	C2	217	51	105	521	140	346	203	117	610	641,4	673,1	12	16	44		37	3/8-18	381
18CB500	105503	9940	C2	235	57	111	564	140	346	206	147	660	641,4	673,1	12	16	44		37	3/8-18	424
20CB500	105504	12100	C2	251	64	97	564	140	346	196	142	711	641,4	673,1	12	16	51		37	3/8-18	424
22CB500	105505	14100	C2	275	70	114	576	152	346	201	157	762	641,4	673,1	12	16	51		37	3/8-18	424
24CB500	105506	17000	C2	305	70	114	589	165	346	206	155	813	692,2	733,4	12	19	57		37	3/8-18	424
26CB525	105507	20900	3/4	364	70	114	614	165	362	221	168	879	743,0	781,1	12	19	57		37	3/8-18	449
28CB525	105508	24000	3/4	391	70	97	640	191	367	236	175	930	768,4	809,6	12	19	57		37	3/8-18	449
SI		Nm @ 5,2 bar	kg [ⓐ]	Dimensions in millimeters																	

Airflex[®] CB Clutch Application



Form CB-409

Air Bridge Arrangement – Technical Data
 Sizes 12 to 45

Size	Part Numbers			
	Element Assembly	Drum	Drum Hub	Air Bridge
12CB350	142098KH	407049	406903	411807
14CB400	142087KH	407051	406905	401546
16CB500	142211KT	407053	406907	408165
18CB500	142264KT	408285	406909	407294
20CB500	142265KT	407055	406911	407296
22CB500	142266KT	408287	406913	407307
24CB500	142267KT	407057	406915	12038

Size	Part Numbers			
	Element Assembly	Drum	Drum Hub	Air Bridge
26CB525	142268KT	408289	406917	411796
28CB525	142269KT	407059	406919	400878
30CB525	142270KT	408343	406921	400203
32CB525	142271KT	407061	406923	400764
36CB525	142272KT	407063	406925	400410
40CB525	142273KT	407065	406927	411797
45CB525	142081KT	407067	406929	411798

Size	English Units							
	Element Ass'y		Drum		Drum Hub		Air Bridge	
	Weight lb	Wk ² lb ft ²	Weight lb	Wk ² lb ft ²	Weight lb	Wk ² lb ft ²	Weight lb	Wk ² lb ft ²
12CB350	30	12	30	5.9	22	0.8	2	0.2
14CB400	35	21	38	10.5	54	3.2	2	0.3
16CB500	74	52	50	19	74	6.6	6	1.3
18CB500	81	70	67	31	83	9	14	10.3
20CB500	88	90	72	43	97	16	15	12.5
22CB500	95	114	79	58	133	25	15	16
24CB500	102	142	93	80	142	33	19	22
26CB525	133	210	108	110	164	43	19	25
28CB525	140	252	117	140	172	55	19	29
30CB525	148	303	140	192	213	69	20	32
32CB525	157	359	160	252	234	97	19	32
36CB525	178	510	160	319	319	157	19	42
40CB525	201	730	209	523	344	214	23	56
45CB525	262	1115	237	758	491	379	24	66

Size	SI Units							
	Element Ass'y		Drum		Drum Hub		Air Bridge	
	Mass kg	J kg m ²	Mass kg	J kg m ²	Mass kg	J kg m ²	Mass kg	J kg m ²
12CB350	14	0,50	14	0,25	10,0	0,03	0,9	0,01
14CB400	16	0,88	17	0,44	24	0,13	0,9	0,01
16CB500	34	2,18	23	0,80	34	0,28	2,7	0,05
18CB500	37	2,94	30	1,30	38	0,38	6,3	0,43
20CB500	40	3,78	33	1,81	44	0,67	6,8	0,53
22CB500	43	4,79	36	2,44	60	1,05	6,8	0,67
24CB500	46	5,96	42	3,36	64	1,39	8,6	0,92
26CB525	60	8,82	49	4,62	74	1,81	8,6	1,05
28CB525	63	10,58	53	5,88	78	2,31	8,6	1,22
30CB525	67	12,73	63	8,06	96	2,90	9,1	1,34
32CB525	71	15,08	72	10,58	106	4,07	8,6	1,34
36CB525	81	21,42	72	13,40	145	6,59	8,6	1,76
40CB525	91	30,66	95	21,97	156	8,99	10	2,35
45CB525	119	46,83	107	31,84	222	15,92	11	2,77

Notes:

- ① Refers to basic part number only and does not include the rotor seal and hose. Element sizes 12 and 14 have two air inlets. All other sizes have either two or four air inlets.
- ② Dynamic torque shown, static torque approximately 25% greater. Torque in each application is dependent upon air pressure and speed.
- ③ Based upon minimum bores. Rotor seal and hose not included.
- ④ Tolerance for sizes:
 12 thru 24, 28 and 32
 +0.000/-0.005 in (+0,00/-0,13 mm)
 26 and 30
 +0.000/-0.008 in (+0,00/-0,20 mm)
 36 thru 45
 +0.000/-0.010 in (+0,00/-0,25 mm)
- ⑤ Refer to Rotor Seal Section for mounting and dimension information.
- ⑥ Based upon minimum bores.

Airflex® CB Clutch Application



Form CB-409

Air Bridge Arrangement – Dimensional Data
 Sizes 12 to 45

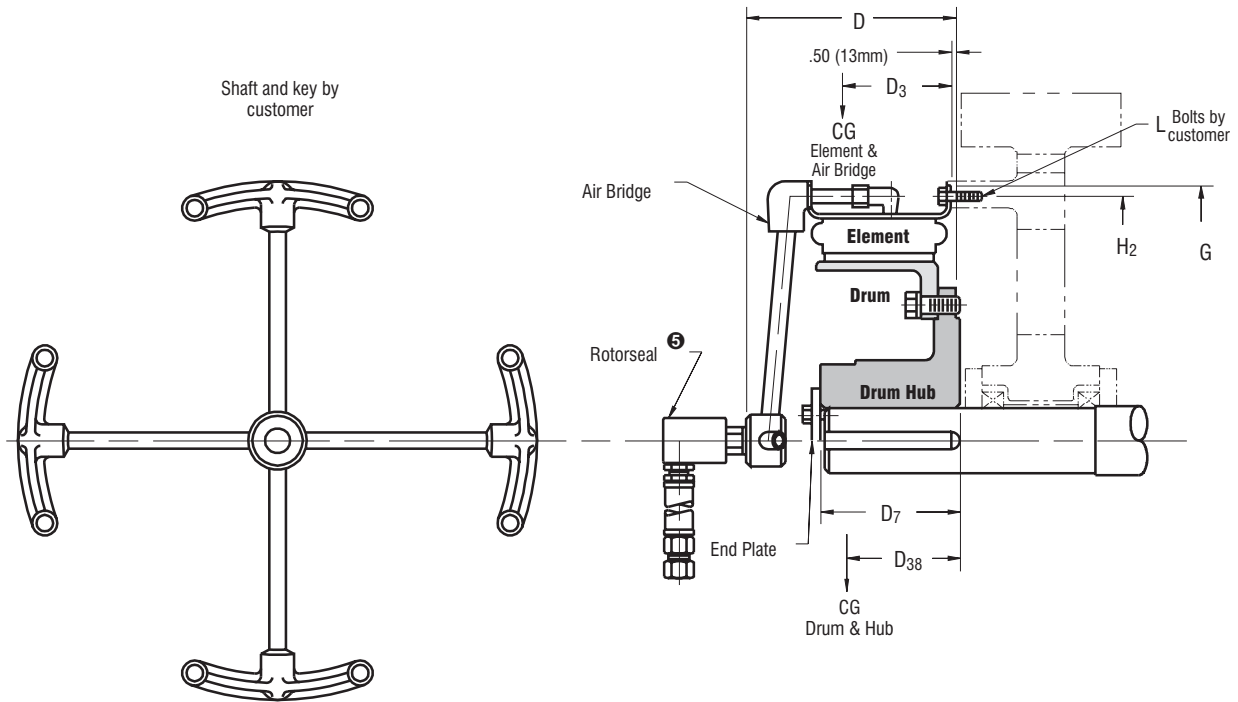

English		lb in @ 75 psi	lb Ⓢ	Dimensions in inches										
12CB350	104420	13300	B3	84	1.50	3.31	7.75	3.25	2.7	2.2	17.625	16.875	14	0.375
14CB400	104421	19700	B3	129	2.00	4.25	8.38	5.00	2.9	3.3	19.625	18.875	16	0.375
16CB500	104422	35200	C2	204	2.00	4.88	9.25	5.75	3.7	3.8	23.500	22.500	8	0.500
18CB500	104423	44000	C2	245	2.25	5.00	9.31	5.75	4.0	4.0	25.500	24.375	12	0.500
20CB500	104424	53600	C2	272	2.50	5.00	9.38	5.75	3.9	4.1	27.500	26.375	12	0.500
22CB500	104425	62300	C2	322	2.75	5.69	9.44	6.50	3.9	4.6	29.500	28.375	12	0.500
24CB500	104426	75000	C2	356	2.75	5.69	9.50	6.50	4.0	4.8	31.500	30.375	16	0.500
26CB525	104427	92400	C2	424	2.75	5.69	10.06	6.50	4.0	4.7	34.000	32.750	16	0.625
28CB525	104428	106000	C2	448	2.75	5.69	10.13	6.50	4.0	4.8	36.000	34.750	16	0.625
30CB525	104429	121000	C2	521	3.00	6.31	10.20	8.00	4.0	5.9	38.000	36.750	16	0.625
32CB525	104430	137000	C2	570	3.00	6.06	10.06	8.00	4.0	6.0	40.000	38.750	18	0.625
36CB525	104431	172000	C2	676	4.00	7.00	10.25	9.00	3.9	6.7	44.625	43.125	18	0.750
40CB525	104432	211000	3/4 RH	777	4.00	7.00	10.50	9.00	4.0	6.8	48.625	47.125	20	0.750
45CB525	104433	260000	3/4 RH	1014	4.38	9.88	10.69	10.00	3.9	7.2	53.625	52.125	24	0.750
Size	Part Number	M, Torque Rating	Rotorseal Size	Weight Mass	Hub Bore		D	D ₇	D ₃₇	D ₃₈	G	H ₂	No.	Dia.
					min	max							L (Bolt)	
					min	max							No.	Dia.
12CB350	104420	1500	B3	38	38	84	197	83	69	56	447,7	428,6	14	10
14CB400	104421	2230	B3	58	51	108	213	127	74	84	498,5	479,4	16	10
16CB500	104422	3980	C2	92	51	124	235	146	94	97	596,9	571,5	8	13
18CB500	104423	4970	C2	111	57	127	237	146	102	102	647,7	619,1	12	13
20CB500	104424	6060	C2	123	64	127	238	146	99	104	698,5	669,9	12	13
22CB500	104425	7040	C2	146	70	144	240	165	99	117	749,3	720,7	12	13
24CB500	104426	8480	C2	161	70	144	241	165	102	122	800,1	771,5	16	13
26CB525	104427	10400	C2	192	70	144	256	165	102	119	863,6	831,9	16	16
28CB525	104428	12000	C2	203	70	144	257	165	102	122	914,4	882,7	16	16
30CB525	104429	13700	C2	236	76	160	259	203	102	150	965,2	933,5	16	16
32CB525	104430	15500	C2	258	76	154	256	203	102	152	1016,0	984,3	18	16
36CB525	104431	19400	C2	306	102	178	260	229	99	170	1133,5	1095,4	18	19
40CB525	104432	23800	3/4 RH	352	102	178	267	229	102	173	1235,1	1197,0	20	19
45CB525	104433	29400	3/4 RH	459	111	251	271	254	99	183	1362,1	1324,0	24	19
SI		Nm @ 5,2 bar	kg Ⓢ	Dimensions in millimeters										

Airflex® CB Clutch and Brake Application



Form CB-429

Gap Mounted Arrangement – Technical Data
 Sizes 12 to 45

Size	Part Numbers				
	Clutch ^③ Element	Brake ^④ Element	Spider	Drum	Hub
12CB350	142098JG	142098JA	408374	411860	406902
14CB400	142087JG	142087JA	408376	411861	406904
16CB500	142211KP	142211KY	408276	411862	406906
18CB500	142264KP	142264KY	408277	411863	406908
20CB500	142265KP	142265KY	408278	411864	406910
22CB500	142266KP	142266KY	408279	411865	406912
24CB500	142267KP	142267KY	408280	411866	406914

Size	Part Numbers				
	Clutch ^③ Element	Brake ^④ Element	Spider	Drum	Hub
26CB525	142268KP	142268KY	408281	411867	406916
26CB525	142269KP	142269KY	408282	411868	406918
30CB525	142270KP	142270KY	407096	411869	406920
32CB525	142271KP	142271KY	407097	411870	406922
36CB525	142272KP	142272KY	407098	411871	406924
40CB525	142273KP	142273KY	407099	411872	406926
45CB525	142443KP	142443KY	502369	411873	406928

English ^⑩	lb	lb-ft ²	lb	lb-ft ²	lb	lb-ft ²	lb	lb-ft ²
12CB350	30	12	46	8.1	61	13	22	0.8
14CB400	35	21	50	11.2	83	24	54	3.2
16CB500	74	52	146	53	109	43	74	6.6
18CB500	81	70	152	63	126	63	83	9
20CB500	88	90	183	91	139	87	97	16
22CB500	95	114	227	123	152	117	133	25
24CB500	102	142	257	150	173	156	142	33
26CB525	133	210	298	220	198	211	164	43
28CB525	140	252	337	270	216	268	172	55
30CB525	148	303	341	390	237	337	213	69
32CB525	157	359	392	453	254	413	234	97
36CB525	178	510	505	710	287	597	319	157
40CB525	201	730	464	774	327	840	344	214
45CB525	262	1115	1294	1887	369	1212	491	379

Size	Weight		Weight		Weight		Weight	
	Element (each)		Spider		Drum		Hub	
	Mass	J	Mass	J	Mass	J	Mass	J
12CB350	14	0,50	21	0,34	28	0,55	10	0,03
14CB400	16	0,88	23	0,47	38	1,01	25	0,13
16CB500	34	2,18	66	2,23	49	1,81	34	0,28
18CB500	37	2,94	69	2,65	57	2,65	38	0,38
20CB500	40	3,78	83	3,82	63	3,65	44	0,67
22CB500	43	4,79	103	5,17	69	4,91	60	1,05
24CB500	46	5,96	117	6,30	79	6,55	64	1,39
26CB525	60	8,82	135	9,24	90	8,86	74	1,81
28CB525	64	10,58	153	11,34	98	11,26	78	2,31
30CB525	67	12,73	155	16,38	108	14,15	97	2,90
32CB525	71	15,08	178	19,03	115	17,35	106	4,07
36CB525	81	21,42	229	29,82	130	25,07	145	6,59
40CB525	91	30,66	211	32,51	148	35,28	156	8,99
45CB525	119	46,83	587	79,25	168	50,90	223	15,92

Notes:

- Dynamic torque shown, static torque approximately 25% greater. Torque in each application is dependent upon air pressure and speed.
- Based upon minimum bores. Rotorseal and hose not included.
- $M (in) = 0.268 (H/2 - \text{radius of bore}) + 0.34$
 $M (mm) = 0,268 (H/2 - \text{radius of bore}) + 8,7$
- American National Pipe Thread
- Pipe tap not required. Thru hole diameter 0.44 in (11 mm).
- Refer to Rotorseal Section for mounting and dimension information.
- Refer to CB Spider Piping and Configuration catalog page for other sizes.
- Element sizes 12 and 14 have two inlets. All other sizes have four air inlets.
- Part number shown for element with one air inlet.
- Based upon minimum bores.

Airflex[®] CB Clutch and Brake Application



Form CB-429

Gap Mounted Arrangement – Dimensional Data
 Sizes 12 to 45

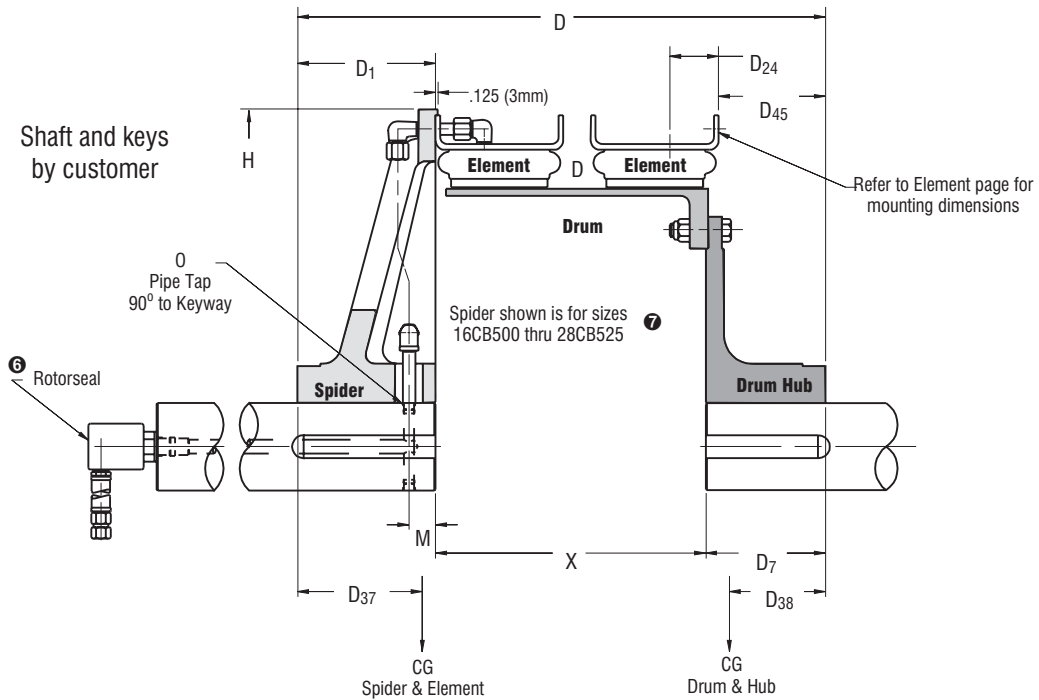

English	lb in @ 75 psi	lb ②	Dimensions in inches													
12CB350	13300	B2	187	1.50	2.63	17.75	4.00	3.25	2.00	3.20	5.80	2.812	18.00	③	⑤	10.50
14CB400	19700	B2	262	2.00	3.56	20.84	4.34	5.00	2.00	3.40	6.70	4.562	20.00	③	⑤	11.50
16CB500	35200	C2	480	2.00	4.13	25.25	5.50	5.75	2.50	5.20	8.00	5.187	24.00	1.44	3/8-18	14.00
18CB500	44000	C2	527	2.25	4.38	25.25	5.50	5.75	2.50	5.30	8.00	5.187	26.00	1.44	3/8-18	14.00
20CB500	53600	C2	599	2.50	3.81	25.25	5.50	5.75	2.50	5.30	8.10	5.187	28.00	1.44	3/8-18	14.00
22CB500	62300	C2	706	2.75	4.50	26.50	6.00	6.50	2.50	5.40	8.30	5.937	30.00	1.44	3/8-18	14.00
24CB500	75000	C2	781	2.75	4.50	27.00	6.50	6.50	2.50	5.60	8.30	5.937	32.00	1.44	3/8-18	14.00
26CB525	92400	C2	932	2.75	4.50	27.63	6.50	6.50	2.50	5.90	8.40	5.906	34.63	1.44	3/8-18	14.63
28CB525	106000	C2	1011	2.75	3.81	28.75	7.50	6.50	2.50	6.60	8.70	5.906	36.63	1.44	3/8-18	14.75
30CB525	121000	C2	1093	3.00	4.50	30.25	7.50	8.00	2.50	6.80	9.50	7.406	38.63	1.44	3/8-18	14.75
32CB525	137000	C2	1201	3.00	4.00	30.25	7.50	8.00	2.50	6.60	9.70	7.406	40.63	1.44	3/8-18	14.75
36CB525	172000	C2	1477	4.00	5.75	32.25	8.50	9.00	2.75	7.10	9.90	8.406	45.25	1.44	1/2-14	14.75
40CB525	211000	3/4 RH	1548	4.00	4.88	32.25	8.50	9.00	2.75	7.60	10.10	8.406	49.25	1.44	1/2-14	14.75
45CB525	260000	3/4 RH	2691	4.38	8.00	35.75	11.00	10.00	2.75	8.80	10.10	9.406	54.25	6.00	1/2-14	14.75
Size	M, Torque Rating	Rotorseal Size	Weight Mass	min max Bore Range		D	D ₁	D ₇	D ₂₄	D ₃₇	D ₃₈	D ₄₅	H ₂	M	④ O	X
12CB350	1500	B2	85	38	67	451	102	83	51	81	147	71.4	457	③	⑤	267
14CB400	2230	B2	119	51	90	529	110	127	51	86	170	115.9	508	③	⑤	292
16CB500	3980	C2	217	51	105	641	140	146	64	132	203	131.7	610	37	3/8-18	356
18CB500	4970	C2	239	57	111	641	140	146	64	135	203	131.7	660	37	3/8-18	356
20CB500	6060	C2	271	64	97	641	140	146	64	135	206	131.7	711	37	3/8-18	356
22CB500	7040	C2	320	70	114	673	152	165	64	137	211	150.8	762	37	3/8-18	356
24CB500	8480	C2	354	70	114	686	165	165	64	142	211	150.8	813	37	3/8-18	356
26CB525	10400	C2	422	70	114	702	165	165	64	150	213	150.0	880	37	3/8-18	372
28CB525	12000	C2	458	70	97	730	191	165	64	168	221	150.0	930	37	3/8-18	375
30CB525	13700	C2	495	76	114	768	191	203	64	173	241	188.1	981	37	3/8-18	375
32CB525	15500	C2	544	76	102	768	191	203	64	168	246	188.1	1032	37	3/8-18	375
36CB525	19400	C2	669	102	146	819	216	229	70	180	251	213.5	1149	37	1/2-14	375
40CB525	23800	3/4 RH	701	102	124	819	216	229	70	193	257	213.5	1251	37	1/2-14	375
45CB525	29400	3/4 RH	1219	111	203	908	279	254	70	224	257	238.9	1378	152	1/2-14	375
SI	Nm @ 5.2 bar		kg ②	Dimensions in millimeters												

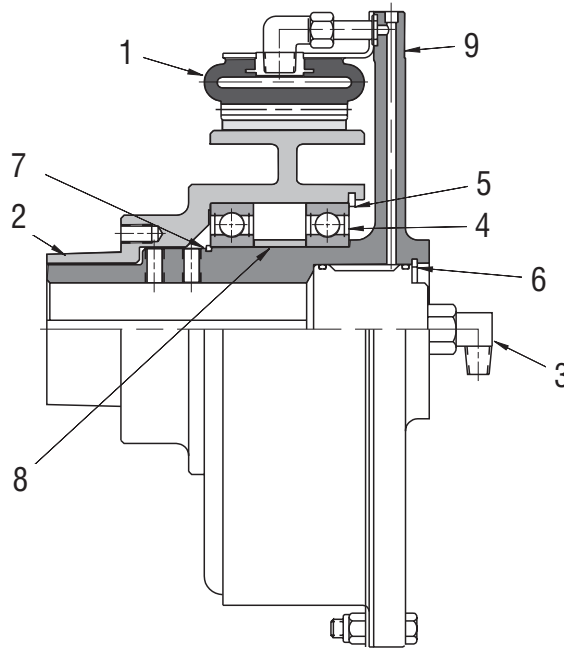

Part Numbers for Complete Applications and Spiders - Item 9

4CB200			6CB200			8CB250			10CB300		
Bore in	Application	Spider	Bore in	Application	Spider	Bore in	Application	Spider	Bore in	Application	Spider
0.875	145987F	407884-02	1.125	145866Q	506516-01	1.625	145873W	506513-01	1.875	145874AC	506514-01
1.000	145987H	407884-04	1.375	145866R	506516-02	1.875	145873X	506513-02	2.125	145874AD	506514-02
1.125	145987G	407884-03	1.625	145866S	506516-03				2.375	145874AE	506514-03

Size	1 Element	2 Drum	3 Rotorseal	4 Bearing	5 Retainer	6 Retainer	7 Retainer	8 Spacer
4CB200	142840JB	410175	145631L	159x78	138x16	138x19	139x6	202737
6CB200	142095JG	407926	145106BM	159x40	138x15	138x56	139x16	202756
8CB250	142096JG	505112	145106BL	159x154	138x58	138x27	136x43	202787
10CB300	142197JG	505196	145107BA	⑥	138x5		⑦	⑧

Notes:

- ① Available only for bores shown.
 Tolerance for bores:
 thru 2.000 +0.0016/-0.000 in
 2.125 and 2.375 +0.0018/-0.000 in
 Square key for bores thru 2.125 in.
 Rectangular key for 2.375 in. bore.
- ② Tolerance +0.000/-0.002 in
 (+0,00/-0,05 mm)
- ③ American National Standard for Unified Screw
 Threads. Bolts and lockwashers furnished with
 clutch.
- ④ American National Pipe Thread
- ⑤ Dynamic torque shown, static torque approxi-
 mately 25% greater. Torque in each application is
 dependent upon air pressure and speed.
- ⑥ Two different size bearings used:
 Bearing adjacent to rotorseal - 159x157
 Bearing adjacent to taper - 159x154
- ⑦ For bearing adjacent to rotorseal - 139x2
 For bearing adjacent to taper - 139x45
- ⑧ Not required. Bearings held by retainers.

Airflex® CB Clutch Application



Form PCB-201

Sheave Clutch Arrangement – Dimensional and Technical Data
 Sizes 4 to 10

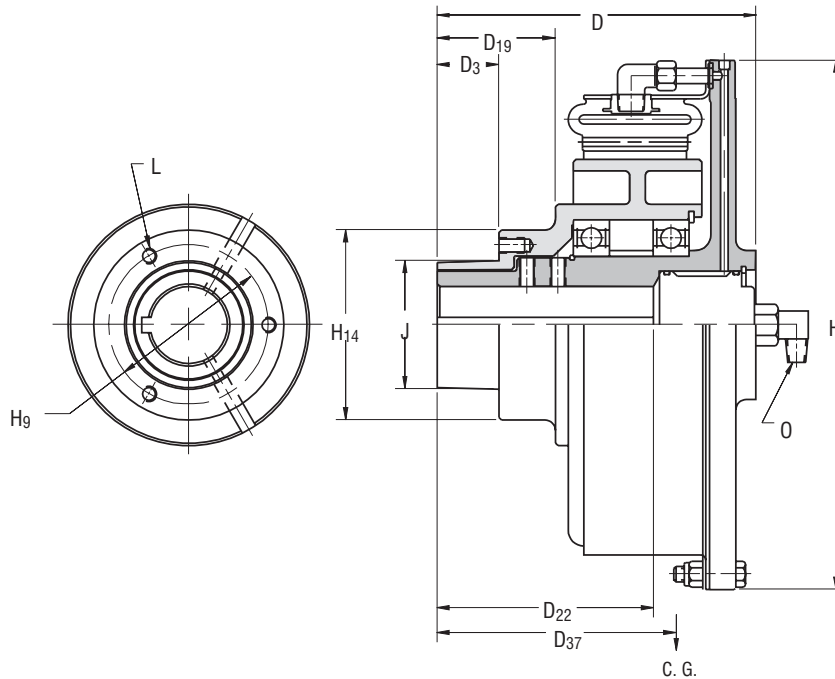

English	lb in @ 75 psi	rpm	lb	lb ft ²	
4CB200	1000	1800	14	0.4	0.1
6CB200	2040	1800	33	1.7	0.4
8CB250	4290	1800	55	3.9	1.2
10CB300	8150	1800	96	10	3.2
Size	Ⓢ M, Torque Rating	Maximum Speed	Weight Mass	Wk ²	
				Element and Spider J	Drum J
4CB200	113	1800	6,3	0,02	0,0042
6CB200	231	1800	15	0,07	0,02
8CB250	485	1800	25	0,16	0,05
10CB300	921	1800	43	0,42	0,13
SI	Nm @ 5, 2 bar	rpm	kg	kg.m ²	

English	Dimensions in inches													
4CB200	0.875-1.000-1.125	5.19	1.56	3.00	0.94	3.06	7.31	2.683	3.13	2.188	SD	1/4-20	1/8-27	
6CB200	1.125-1.375-1.625	6.69	2.75	4.50	1.38	4.31	10.75	3.312	3.88	2.813	SK	5/16-18	1/4-18	
8CB250	1.625-1.875	7.75	2.88	5.41	1.50	4.97	12.88	3.875	4.63	3.126	SF	3/8-16	1/4-18	
10CB300	1.875-2.125-2.375	9.75	4.50	7.13	1.88	6.44	15.38	5.000	6.00	3.836	E	1/2-13	1/2-14	
Size	Ⓛ Bores Available	D	D ₁₉	D ₂₂	D ₃₀	D ₃₇	H	H ₉	H ₁₄	J Ⓜ		Ⓢ	Ⓛ	Ⓞ
										Dia. Lg End	Fits QD Hub			
4CB200	0.875-1.000-1.125	132	40	76	24	78	186	68,1	80	55,6	SD	1/4-20	1/8-27	
6CB200	1.125-1.375-1.625	170	70	114	35	109	273	84,1	99	71,5	SK	5/16-18	1/4-18	
8CB250	1.625-1.875	197	73	137	38	126	327	98,4	118	79,4	SF	3/8-16	1/4-18	
10CB300	1.875-2.125-2.375	248	114	181	48	164	391	127,0	152	97,4	E	1/2-13	1/2-14	
SI	inches	Dimensions in millimeters												

Airflex[®] CB Clutch Application



Form PCB-203

Bearing Mounted Arrangement – Component Part Numbers
Sizes 6 to 14

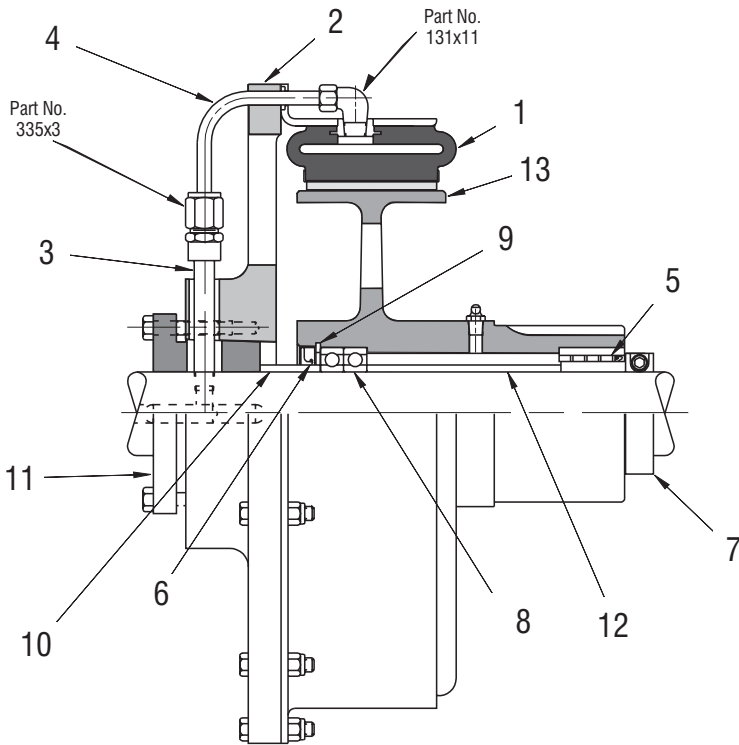

Shaft Dia (in)	5 Needle Bearing	6 Oil Seal	7 Safety Collar	8 Ball Bearing	9 Retainer Ring
1.250	160x43	113x95	149x198	159x135	138x29
1.375	160x44	113x267	149x200	159x136	138x30
1.500	160x45	113x268	149x202	159x134	138x27
1.625	160x46	113x269	149x204	159x137	138x31
1.750	160x47	113x270	149x206	159x138	138x32
1.875	160x48	113x271	149x208	159x139	138x16
2.000	160x49	113x259	149x210	159x132	138x26
2.250	160x51	113x273	149x213	159x141	138x34
2.375	160x52	113x85	149x214	159x142	138x22
2.500	160x53	113x276	149x216	159x143	138x21

Size	1 Element	2 Spider	3 Pipe Nipple	4 Air Tube
6CB200	142095JC	405307	⊕	201641
8CB250	142096JC	405308	70x135	201640
10CB300	142197JC	405309	70x121	201598
12CB350	142098JC	405310	70x212	201654
14CB400	142087JC	405311	70x121	201605

Shaft Diameter in	6CB200 & 8CB250		6CB200		8CB250	
	10 Spacer	11 Bushing	12 Spacer	13 Drum	12 Spacer	13 Drum
1.250	305137-01	304040-01	305136-22	406566-01	305136-29	406571-01
1.375	305137-02	304040-03	305136-23	406566-02	305136-30	406571-02
1.500	305137-03	304040-05	305136-24	406566-03	305136-31	406571-03
1.625	305137-04	304040-07	305136-25	406566-04	305136-32	406571-04
1.750	305137-05	304040-09	305136-26	406566-05	305136-33	406571-05
1.875	305137-06	304040-11	305136-27	406566-06	305136-34	406571-06
2.000	305137-07	304040-13	305136-28	406566-07	305136-35	406571-07

Shaft Diameter in	10CB300 thru 14CB400				10CB300		12CB350		14CB400	
	10 Spacer	11 Bushing	12 Spacer	13 Drum	12 Spacer	13 Drum	12 Spacer	13 Drum	12 Spacer	13 Drum
1.750	305137-08	304042-01	305136-08	405141-01	305136-01	405142-01	305136-15	405143-01		
1.875	305137-09	304042-03	305136-09	405141-02	305136-02	405142-02	305136-16	405143-02		
2.000	305137-10	304042-05	305136-10	405141-03	305136-03	405142-03	305136-17	405143-03		
2.250	305137-12	304042-09	305136-12	405141-05	305136-05	405142-05	305136-19	405143-05		
2.375	305137-13	304042-11	305136-13	405141-06	305136-06	405142-06	305136-20	405143-06		
2.500	305137-14	304042-13	305136-14	405141-07	305136-07	405142-07	305136-21	405143-07		

Airflex[®] CB Clutch Application



Form PCB-203

Bearing Mounted Arrangement – Dimensional and Technical Data
 Sizes 6 to 14

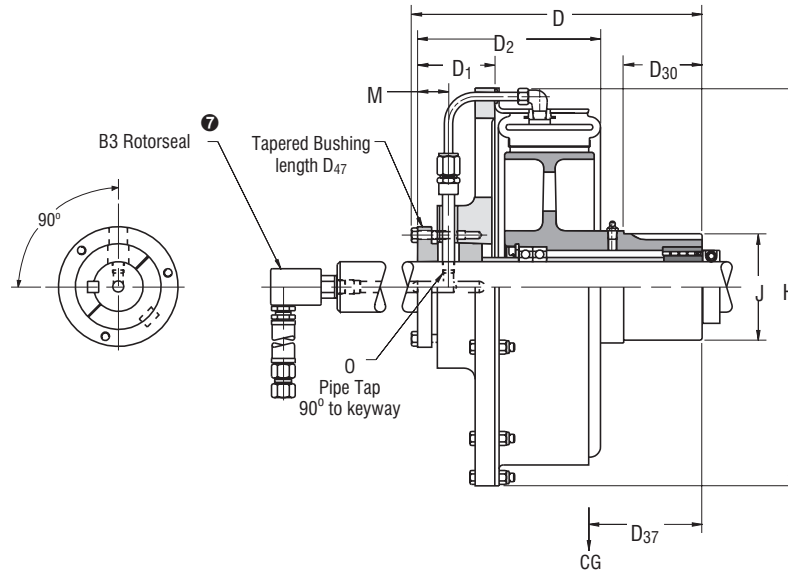

English		lb in @ 75 psi	Dimensions in inches										
6CB200	105782	2040	1.250 thru 2.000	10.75	2.69	6.69	3.25	0.54	6.08	2.50	10.75	4.252	1.38
8CB250	105783	4290	1.250 thru 2.000	11.25	2.69	7.19	3.25	0.54	6.48	2.50	12.88	4.252	1.38
10CB300	105784	8150	1.750 thru 2.500	13.06	3.44	8.56	3.50	0.73	7.76	2.88	15.38	4.752	1.38
12CB350	105785	13300	1.750 thru 2.500	13.69	3.44	9.19	3.50	0.73	8.28	2.88	17.63	4.752	1.38
14CB400	105786	19700	1.750 thru 2.500	14.19	3.44	9.69	3.50	0.73	8.69	2.88	19.63	4.752	1.38
Size	Part Number ^①	M. Torque Rating ^②	Available for Shaft Diameters of: ^③	D	D ₁	D ₂	D ₃₀	D ₃₃	D ₃₇	D ₄₇	H	J ^④	M
6CB200	105782	231	1.250 thru 2.000	273	68	170	83	14	154	64	273	108,0	35
8CB250	105783	485	1.250 thru 2.000	286	68	183	83	14	165	64	327	108,0	35
10CB300	105784	921	1.750 thru 2.500	332	87	217	89	19	197	73	391	120,7	35
12CB350	105785	1500	1.750 thru 2.500	348	87	233	89	19	210	73	448	120,7	35
14CB400	105786	2230	1.750 thru 2.500	360	87	246	89	19	221	73	499	120,7	35
SI		Nm @ 5, 2 bar	Dimensions in millimeters										

English	lb ^⑤	lb-ft ^⑤
6CB200	42	2.0
8CB250	51	4.1
10CB300	88	12
12CB350	120	22
14CB400	137	32

Shaft Dia. in	rpm max ^⑥
1.250	1800
1.375	1700
1.500	1700
1.625	1500
1.750	1350

Shaft Dia. in	rpm max ^⑥
1.875	1350
2.000	1200
2.250	1100
2.375	1000
2.500	1000

Size	Weight Mass	Wk ²	
		Element & Spider	Drum
		J	
6CB200	19	0,08	0,03
8CB250	23	0,17	0,04
10CB300	40	0,50	0,11
12CB350	54	0,92	0,21
14CB400	62	1,34	0,38
SI	kg ^⑤	kg-m ² ^⑤	

Notes:

- Refers to basic part number only and does not include the rotor seal and hose. When ordering, specify shaft diameter.
- Dynamic torque shown, static torque approximately 25% greater. Torque in each application is dependent upon air pressure and speed.
- Available only for inch series shafting in 0.125 increments. Use standard square keys.
- Tolerance +/-0.0005 in (+/-0,01 mm)
- Based upon minimum bores.
- Based on needle bearing limitation.
- Refer to Rotorseal Section for mounting and dimension information.
- Part numbers for shaft diameters:
 1.250 thru 1.500 in - 70x135
 All other diameters - 70x45

Forms 204,205,206, & 208 Tapered Bushing Arrangements – Dimensional Data
 Sizes 4 to 14

PCB - 205 Arrangement

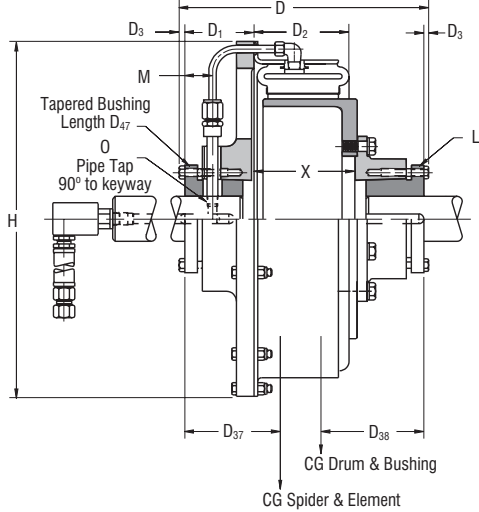

PCB - 206 Arrangement

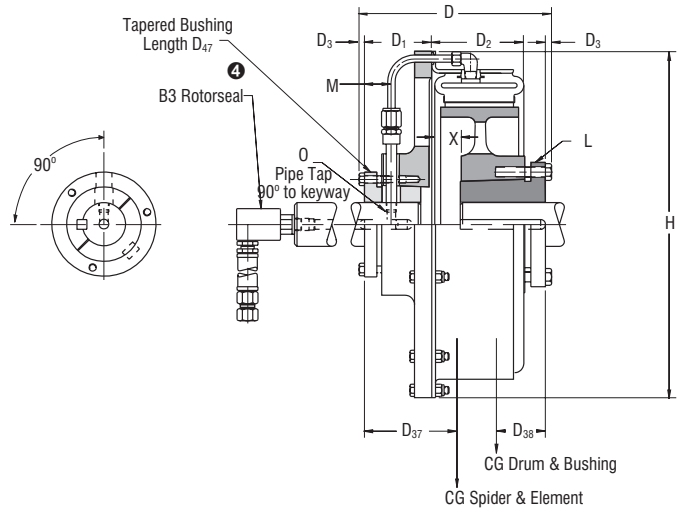

English	Dimensions in inches											
4CB200	0.875 thru 1.437	0.875 thru 1.437						103474	4.89	2.0	1.2	0.56
6CB200	1.250 thru 2.000	1.250 thru 2.000	103433	9.13	2.0	2.2	3.56	103475	6.88	2.0	1.4	0.44
8CB250	1.250 thru 2.000	1.250 thru 2.000	103434	9.63	2.4	2.7	4.06	103476	6.88	2.7	1.7	1.31
10CB300	1.750 thru 2.500	1.750 thru 2.500	103435	11.81	3.2	3.2	5.50	103477	8.31	3.2	2.0	2.00
	1.750 thru 2.500	2.563 thru 3.125	103727	12.78	3.2	3.9	4.88	103737	9.28	3.2	2.5	1.38
	2.563 thru 3.125	2.563 thru 3.125	103445	13.75	3.2	3.9	4.25	103478	10.25	3.2	2.5	0.75
	2.563 thru 3.125	1.750 thru 2.500	103728	12.78	3.2	3.2	4.88	103738	9.28	3.2	2.0	1.38
12CB350	1.750 thru 2.500	1.750 thru 2.500	103446	12.44	3.3	3.4	6.13	103479	8.94	3.2	1.3	2.63
	1.750 thru 2.500	2.563 thru 3.125	103729	13.41	3.3	3.9	5.50	103739	9.91	3.2	2.5	2.00
	2.563 thru 3.125	2.563 thru 3.125	103447	14.38	3.7	3.9	4.88	103480	10.88	3.2	2.5	1.38
	2.563 thru 3.125	1.750 thru 2.500	103730	13.41	3.3	3.4	5.50	103740	9.91	3.2	1.3	2.00
14CB400	1.750 thru 2.500	1.750 thru 2.500	103448	12.94	3.7	3.3	6.63	103499	9.44	3.7	2.0	3.13
	1.750 thru 2.500	2.563 thru 3.125	103731	13.91	3.7	4.1	6.00	103741	10.41	3.7	3.0	2.50
	2.563 thru 3.125	2.563 thru 3.125	103449	14.88	3.7	4.1	5.88	103482	11.38	3.7	3.0	1.88
	2.563 thru 3.125	1.750 thru 2.500	103732	13.91	3.7	3.3	6.00	103742	10.41	3.7	2.0	2.50
Size	Spider	Hub	Part No.	D	D ₃₇	D ₃₈	X	Part No.	D	D ₃₇	D ₃₈	X
	Shaft Diameter ⁵		PCB-205 Arrangement					PCB-206 Arrangement				
	Spider	Hub	Part No.	D	D ₃₇	D ₃₈	X	Part No.	D	D ₃₇	D ₃₈	X
4CB200	0.875 thru 1.437	0.875 thru 1.437						103474	124	51	30	14
6CB200	1.250 thru 2.000	1.250 thru 2.000	103433	232	51	56	90	103475	175	51	36	11
8CB250	1.250 thru 2.000	1.250 thru 2.000	103434	245	61	69	103	103476	175	61	43	33
10CB300	1.750 thru 2.500	1.750 thru 2.500	103435	300	81	81	140	103477	211	81	51	51
	1.750 thru 2.500	2.563 thru 3.125	103727	325	81	99	124	103737	236	81	64	35
	2.563 thru 3.125	2.563 thru 3.125	103445	349	81	99	108	103478	260	81	64	19
	2.563 thru 3.125	1.750 thru 2.500	103728	325	81	81	124	103738	236	81	51	35
12CB350	1.750 thru 2.500	1.750 thru 2.500	103446	316	84	86	156	103479	227	81	33	67
	1.750 thru 2.500	2.563 thru 3.125	103729	341	84	99	140	103739	252	81	64	51
	2.563 thru 3.125	2.563 thru 3.125	103447	365	94	99	124	103480	276	81	64	35
	2.563 thru 3.125	1.750 thru 2.500	103730	341	84	86	140	103740	252	94	33	51
14CB400	1.750 thru 2.500	1.750 thru 2.500	103448	329	94	84	168	103499	240	94	51	80
	1.750 thru 2.500	2.563 thru 3.125	103731	353	94	104	152	103741	264	94	76	64
	2.563 thru 3.125	2.563 thru 3.125	103449	378	94	104	149	103482	289	94	76	48
	2.563 thru 3.125	1.750 thru 2.500	103732	353	94	84	152	103742	264	94	51	64
SI	inches		Dimensions in millimeters									

Shaft Diameter	D ₁	D ₃	D ₄₇	M
0.875 thru 1.437	2.06	0.20	1.94	1.13
1.250 thru 2.000	2.69	0.28	2.50	1.38
1.750 thru 2.500	3.44	0.28	2.88	1.38
2.563 thru 3.125	4.31	0.38	4.38	2.25
English	Dimensions in inches			

Shaft Diameter ⁵	D ₁	D ₃	D ₄₇	M
0.875 thru 1.437	52	5	49	29
1.250 thru 2.000	68	7	64	35
1.750 thru 2.500	87	7	73	35
2.563 thru 3.125	109	10	111	57
SI	Dimensions in millimeters			

Airflex® CB Clutch and Brake Applications



Forms 204, 205, 206, Tapered Bushing Arrangements – Dimensional Data
& 208 Sizes 4 to 14

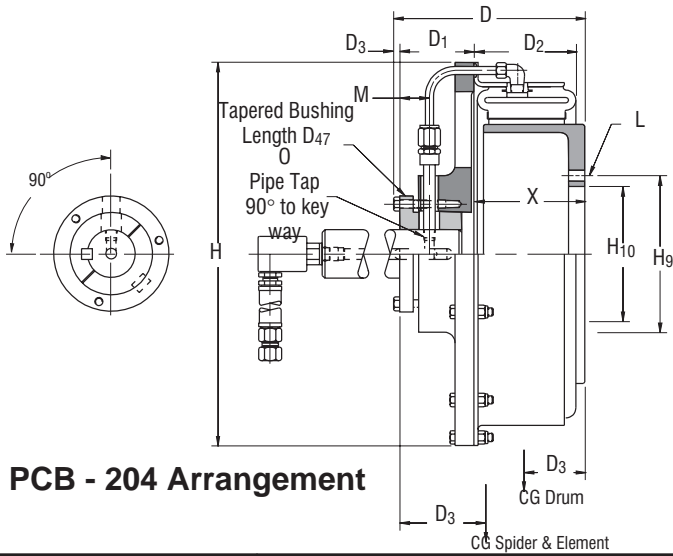

PCB - 208 Arrangement

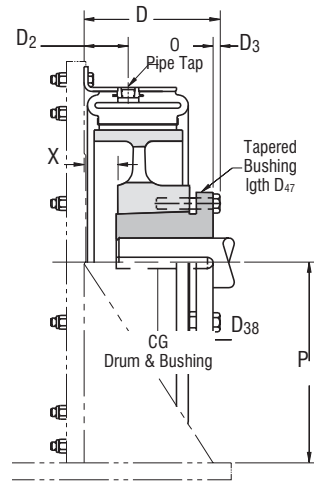

English	lbin @ 75 psi	Dimensions in inches												
4CB200	1000	2.63	1.38	7.25					1/8-27	1/8-27	3.88			
6CB200	2040	2.94	1.56	10.75	4.250	3.500	6	0.406	1/4-18	3/8-18	5.63			
8CB250	4290	3.44	1.91	12.47	5.250	4.250	8	0.406	1/4-18	3/8-18	6.69			
10CB300	8150	4.13	2.00	15.37	7.250	6.250	6	0.531	1/4-18	3/8-18	7.94			
12CB350	13300	4.72	2.00	17.62	7.250	6.250	6	0.531	1/4-18	3/8-18	9.06			
14CB400	19700	5.22	2.00	19.62	9.250	8.250	6	0.531	1/4-18	3/8-18	10.00			
Size	Torque Rating	D ₂	D ₂₄	H	H ₉	H ₁₀	number size		O	O ₄	P min.			
							L (Bolt)							
							number	size						
4CB200	113	67	35	184					1/8-27	1/8-27	99			
6CB200	231	75	40	273	108,0	88,9	6	10,3	1/4-18	3/8-18	143			
8CB250	485	87	49	317	133,4	108,0	8	10,3	1/4-18	3/8-18	170			
10CB300	921	105	51	390	184,2	158,8	6	13,5	1/4-18	3/8-18	202			
12CB350	1500	120	51	448	184,2	158,8	6	13,5	1/4-18	3/8-18	230			
14CB400	2230	133	51	498	235,0	209,6	6	13,5	1/4-18	3/8-18	254			
SI	Nm @ 5,2 bar	Dimensions in millimeters												
English	Dimensions in inches													
4CB200	0.875 thru 1.437			2.0				103502	2.63	1.2	0.44			
6CB200	1.250 thru 2.000		103419	6.28	2.0	1.1	3.50	103503	3.41	1.4	0.63			
8CB250	1.250 thru 2.000		103420	6.78	2.4	1.1	4	103504	3.91	1.7	0.94			
10CB300	1.750 thru 2.500		103421	8.22	3.2	1.4	5.06	103505	4.59	2.0	1.44			
	2.563 thru 3.125		103422	9.19	4.0	1.4	4.44	103506	5.56	2.5	0.81			
12CB350	1.750 thru 2.500		103423	8.84	3.5	1.5	5.69	103507	5.22	1.3	2.06			
	2.563 thru 3.125		103424	9.81	4.1	1.5	5.06	103508	6.17	2.5	1.44			
14CB400	1.750 thru 2.500		103425	9.34	3.8	1.6	6.19	103509	5.72	2.0	2.56			
	2.563 thru 3.125		103426	10.31	4.4	1.6	5.56	103510	6.69	3.0	1.94			
Size	Shaft Diameter	Part No.	D	D ₃₇	D ₃₈	X	Part No.	D	D ₃₈	X				
	for Spider or Drum ⑤						PCB-204 Assembly				PCB-208 Assembly			
	Shaft Diameters		Part No	D	D ₃₇	D ₃₈	X	Part No.	D	D ₃₈	X			
4CB200	0.875 thru 1.437			51			103502	67	30	11				
6CB200	1.250 thru 2.000		103419	160	51	28	89	103503	87	36	16			
8CB250	1.250 thru 2.000		103420	172	61	28	102	103504	99	43	24			
10CB300	1.750 thru 2.500		103421	209	81	36	129	103505	117	51	37			
	2.563 thru 3.125		103422	233	102	36	113	103506	141	64	21			
12CB350	1.750 thru 2.500		103423	225	89	38	145	103507	133	33	52			
	2.563 thru 3.125		103424	249	104	38	129	103508	157	64	37			
14CB400	1.750 thru 2.500		103425	237	97	41	157	103509	145	51	65			
	2.563 thru 3.125		103426	262	112	41	141	103510	170	76	49			
SI	inches Dimensions in millimeters													

Notes appear on component parts page (p B-38).

Airflex[®] CB Clutch and Brake Applications



Forms 204, 205,
206, & 208

Tapered Bushing Arrangements – Component Part Numbers
Sizes 4 to 14

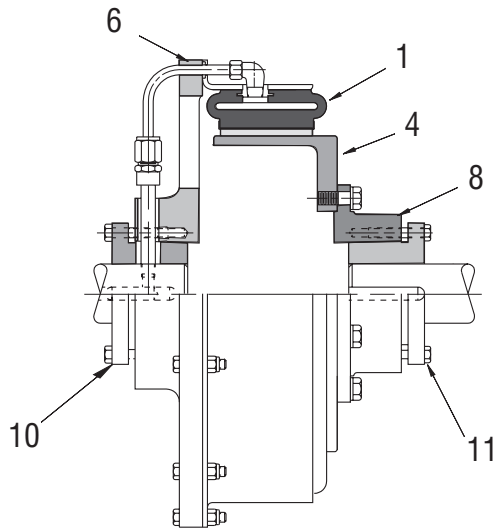

PCB - 205 Arrangement

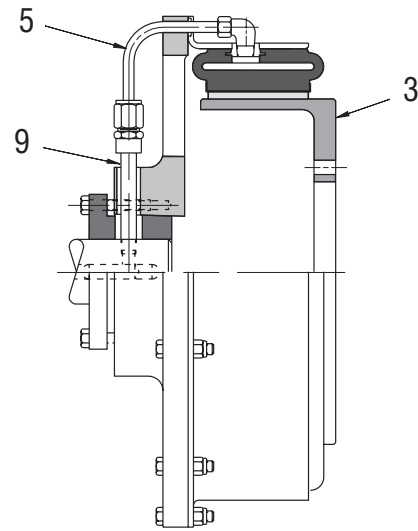

PCB - 204 Arrangement

Size	1 Clutch Element	2 Brake Element	3 Drum w/thru holes	4 Drum w/tapped holes	5 Air Tube
4CB200	142840JD	142840JA			202735
6CB200	142095JC	142095JA	407043	407044	201641
8CB250	142096JC	142096JA	407045	407046	201640
10CB300	142197JC	142197JA	407047	407048	201598
12CB350	142098JC	142098JA	407049	407050	201654
14CB400	142087JC	142087JA	407051	407052	201605

Size	Shaft Diameter in	6	7	8	9
		Spider	Integral Drum	Drum Hub	Pipe Nipple
4CB200	0.875-1.125	407855	407854		70 x 185
	1.188-1.438	407855	407854		70 x 5
6CB200	1.250-2.000	405307	405325	405326	70 x 135
8CB250	1.250-2.000	405308	405341	405326	70 x 19
10CB300	1.750-2.500	405309	405342	405331	70 x 121
	2.563-3.125	405312	405343	405334	70 x 19
12CB350	1.750-2.500	405310	405344	405331	70 x 212
	2.563-3.125	405313	405345	405334	70 x 212
14CB400	1.750-2.500	405311	405346	405323	70 x 145
	2.563-3.125	405314	405347	405324	70 x 19

4CB200		
Shaft Diameter in	10 Bushing	11 Bushing
0.875	304038-1	304037-7
0.938	304038-2	304037-8
1.000	304038-3	304037-9
1.063	304038-4	304037-10
1.125	304038-5	304037-11
1.188	304038-6	304037-12
1.250	304038-7	304037-13
1.313	304038-8	304037-14
1.375	304038-9	304037-15
1.438	304038-10	304037-16

6CB200 & 8CB250		
Shaft Diameter in	10 Bushing	11 Bushing
1.250	304040-1	304039-9
1.313	304040-2	304039-10
1.375	304040-3	304039-11
1.438	304040-4	304039-12
1.500	304040-5	304039-13
1.563	304040-6	304039-14
1.625	304040-7	304039-15
1.688	304040-8	304039-16
1.750	304040-9	304039-17
1.813	304040-10	304039-18

Airflex® CB Clutch and Brake Applications



Forms 204, 205,
206, & 208

Tapered Bushing Arrangements – Component Part Numbers
Sizes 4 to 14

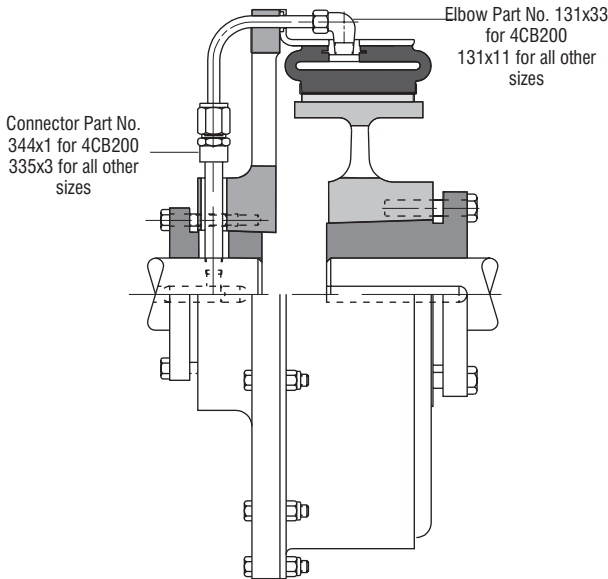

PCB - 206 Arrangement

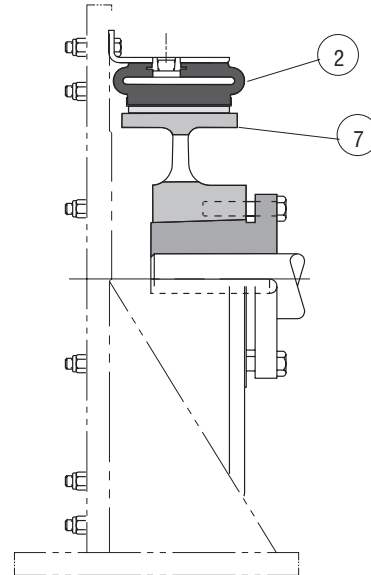

PCB - 208 Arrangement

10CB300, 12CB350, 14CB400		
Shaft Diameter in	10 Bushing	11 Bushing
1.750	304042-1	304041-11
1.813	304042-2	304041-12
1.875	304042-3	304041-13
1.938	304042-4	304041-14
2.000	304042-5	304041-15
2.063	304042-6	304041-16
2.125	304042-7	304041-17
2.188	304042-8	304041-18
2.250	304042-9	304041-19
2.313	304042-10	304041-20
2.375	304042-11	304041-21
2.438	304042-12	304041-22
2.500	304042-13	304041-23

10CB300, 12CB350, 14CB400		
Shaft Diameter in	10 Bushing	11 Bushing
2.563	304044-1	304043-12
2.625	304044-2	304043-13
2.688	304044-3	304043-14
2.750	304044-4	304043-15
2.813	304044-5	304043-16
2.875	304044-6	304043-17
2.938	304044-7	304043-18
3.000	304044-8	304043-19
3.063	304044-9	304043-20
3.125	304044-10	304043-21

Size	1 Element		4 Drum		6 Spider		7 Integral Drum		8 Drum Hub		10 or 11 Bushing	
	Weight lb	Wk ² lb ft ²	Weight lb	Wk ² lb ft ²	Weight lb	Wk ² lb ft ²	Weight lb	Wk ² lb ft ²	Weight lb	Wk ² lb ft ²	Weight lb	Wk ² lb ft ²
4CB200	2.5	0.2			4.2	0.2	3.3	0.1			1.6	.01
6CB200	7	1	5.5	0.3	10	0.9	9	0.3	6	0.2	3.5	0.1
8CB250	9	2	12.5	1.1	16	2	14	1	6	0.2	4.4	0.1
10CB300	19	6	19	2.7	41	5	25	2.6	16	1	16	0.5
12CB350	26	11	30	5.9	44	10	39	5.8	16	1	16	0.5
14CB400	31	17	38	10.5	41	14	48	11.4	23	2	16	0.5

Notes:

- ① Dynamic torque shown, static torque approximately 25% greater. Torque in each application is dependent upon air pressure and speed.
- ② Tolerance +0.003/-0.000 in.
- ③ American National Pipe Thread
- ④ AA2 Rotorseal for 4CB200.
B3 Rotorseal for all other sizes.
Refer to Section for mounting and dimensional information.
- ⑤ For inch series shafting.

Airflex[®] CB Spider Piping and Configuration



Form CB 417

Shaft to Clutch Element piping

Element Sizes 6 to 14

Spiders for these sizes have internal air passages in the spider spokes.

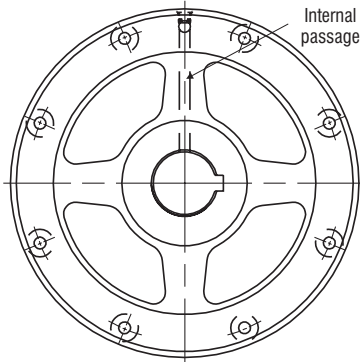

Single Connection

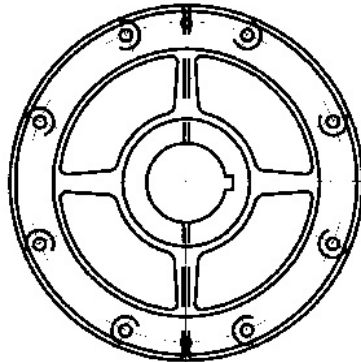

Two Connections

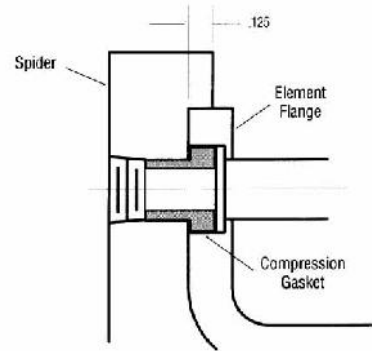

Element Sizes 16 to 45

External piping versus number of connections

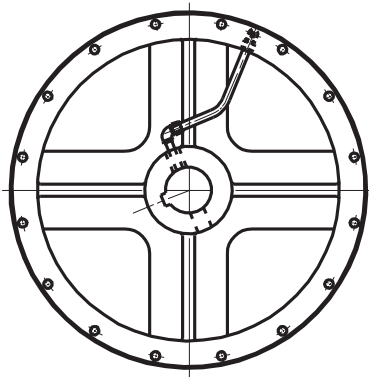

Single Connection

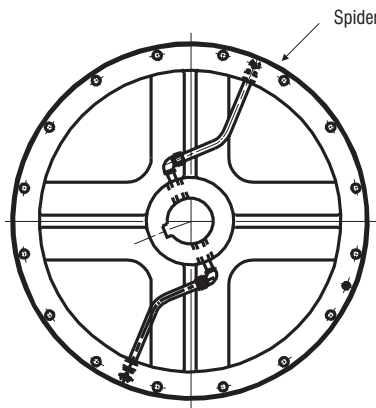

Two Connections

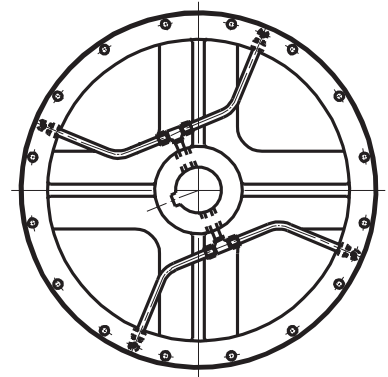

Four Connections

Spider Configuration versus Element size

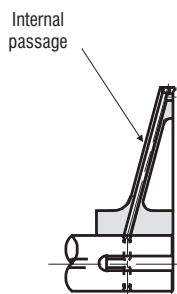

Sizes
6 thru 14

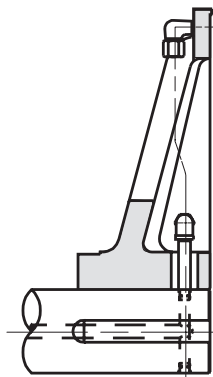

Sizes
16 thru 28

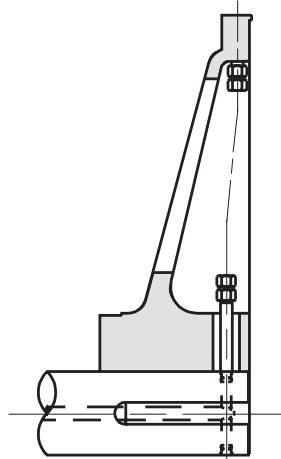

Sizes
30 thru 40

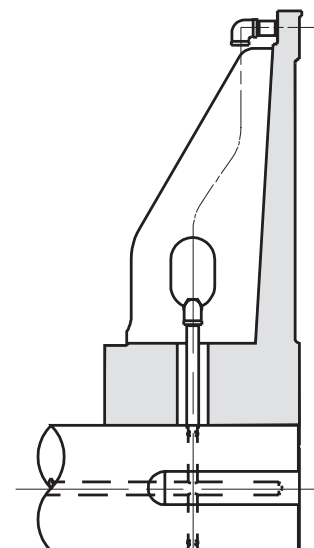

Size
45

Airflex[®] CB Mounting Components



Form CB 415

Element Spiders – Dimensional and Technical Data
Single and Dual sizes 6 to 45

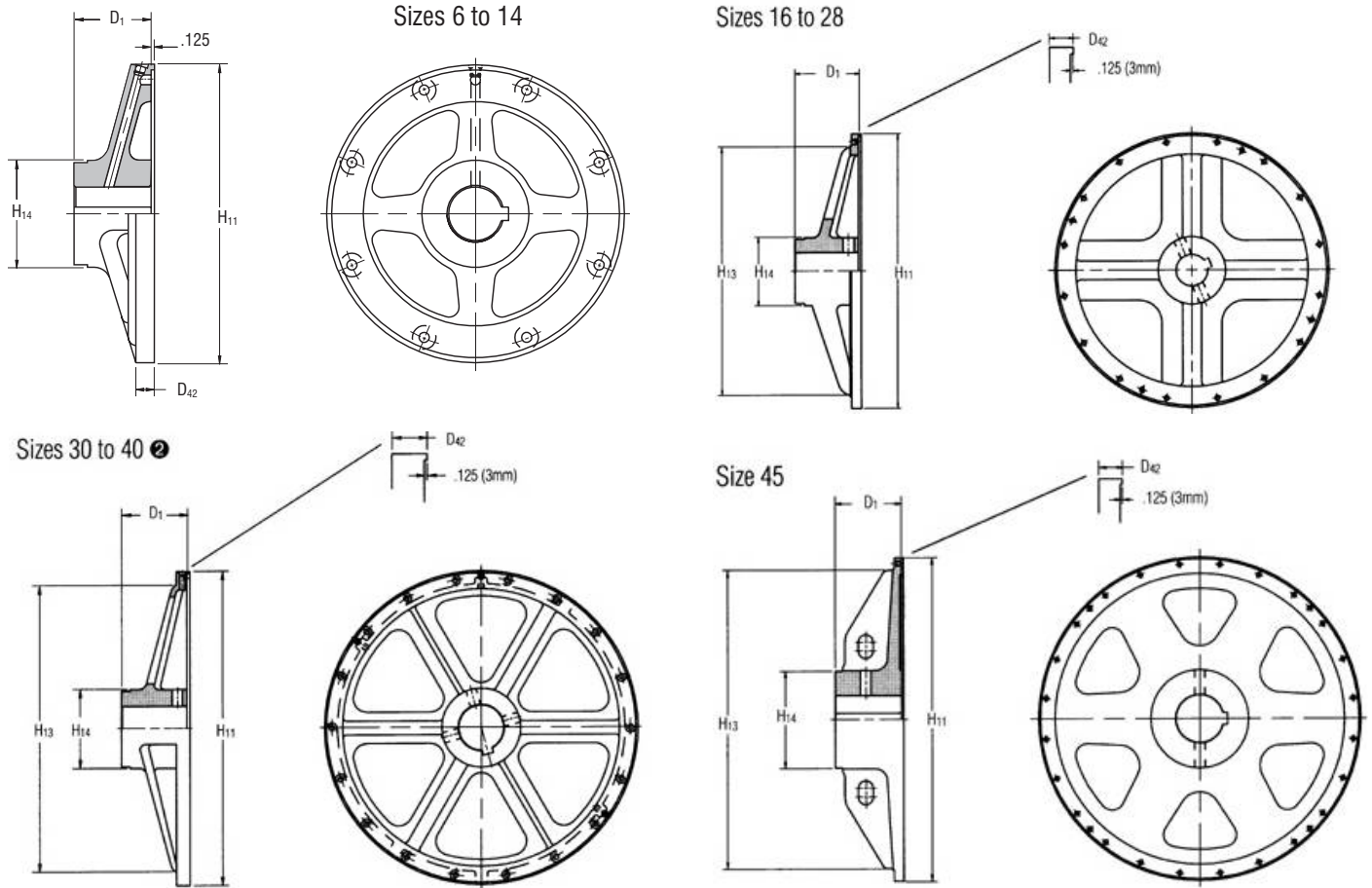

Size	Part No. for:		English Units							SI Units						
			Weight lb	Wk ² lb ft ²	Dimensions in inches					Mass kg	J kg m ²	Dimensions in millimeters				
	Single Connection	Multi- Connection			D ₁	D ₄₂	H ₁₁	H ₁₃	H ₁₄			D ₁	D ₄₂	H ₁₁	H ₁₃	H ₁₄
6CB200	408367	408368	15	1.7	2.50	0.56	11.13	N/A	4.00	6,8	0,07	64	14	283	N/A	102
8CB250	408369	408370	19	2.3	2.88	0.56	13.25	N/A	4.00	8,6	0,10	73	14	337	N/A	102
10CB300	408371	408372	40	5.3	3.56	0.62	15.75	N/A	6.00	18	0,22	91	16	400	N/A	152
12CB350	408373	408374	46	8.1	4.00	0.59	18.00	N/A	6.00	21	0,34	102	15	457	N/A	152
14CB400	408375	408376	50	11.2	4.34	0.59	20.00	N/A	6.00	23	0,47	110	15	508	N/A	152
16CB500	N/A	408276	146	53	5.50	1.06	24.00	21.25	7.00	66	2,23	140	27	610	540	178
18CB500	N/A	408277	152	63	5.50	1.06	26.00	23.25	8.00	69	2,65	140	27	660	591	203
20CB500	N/A	408278	183	91	5.50	1.06	28.00	25.25	8.00	83	3,82	140	27	711	641	203
22CB500	N/A	408279	227	123	6.00	1.06	30.00	27.00	8.50	103	5,17	152	27	762	686	216
24CB500	N/A	408280	257	150	6.50	1.06	32.00	29.00	8.50	116	6,30	165	27	813	737	216
26CB525	N/A	408281	298	220	6.50	1.06	34.63	31.00	9.00	135	9,24	165	27	879	787	229
28CB525	N/A	408282	337	270	7.50	1.06	36.63	33.50	9.00	153	11,34	191	27	930	851	229
30CB525	N/A	407096	341	390	7.50	1.69	38.63	35.00	9.50	154	16,38	191	43	981	889	241
32CB525	N/A	407097	392	453	7.50	1.69	40.63	37.00	9.50	178	19,03	191	43	1032	940	241
36CB525	N/A	407098	505	710	8.50	1.69	45.25	41.50	11.38	229	29,82	216	43	1149	1054	289
40CB525	N/A	407099	464	774	8.50	1.69	49.25	46.75	11.00	210	32,51	216	43	1251	1187	279
45CB525	N/A	502369	1294	1887	11.00	1.31	54.25	50.48	16.50	586	79,25	279	33	1378	1282	419

Notes:

- ① Based upon minimum bores.
- ② Air inlet locations vary. Consult factory for exact location.

Airflex® CB Mounting Components



Form CB 428

External Flange Drums – Dimensional and Technical Data
Single and Dual sizes 6 to 45

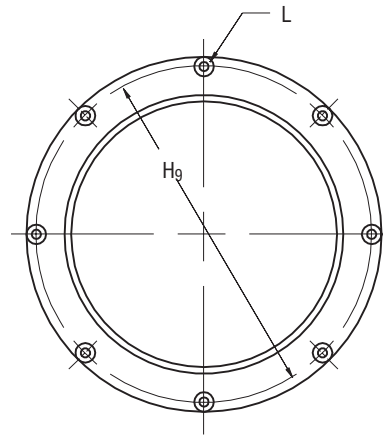
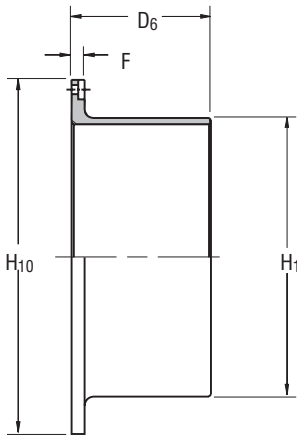

Size	Part Numbers	
	Single Drum	Dual Drum
12CB350	411778	408648
14CB400	411779	411707
16CB500	411780	408682
18CB500	411781	410523
20CB500	411782	404605
22CB500	411783	406030
24CB500	411784	402145
26CB525	411786	411453
28CB525	411785	404942
30CB525	411787	N/A
32CB525	411788	N/A
36CB525	411789	N/A
40CB525	411790	N/A
45CB525	411791	N/A

English	Dimensions in inches															
	Single & Dual		Single Drum						Dual Drum							
12CB350	0.75	12	6.00	13.125	13.875	8	0.406	26	6.4	12.06	17.250	18.375	8	0.531	100	28
14CB400	0.75	14	6.63	17.250	18.375	8	0.531	45	18	13.00	21.375	22.500	6	0.656	103	47
16CB500	0.75	16	8.00	19.250	20.375	8	0.531	63	31	14.31	25.250	26.500	12	0.656	182	103
18CB500	0.75	18	8.00	21.375	22.500	6	0.531	72	44	16.00	25.250	26.500	12	0.656	201	126
20CB500	1.00	20	8.00	25.250	26.500	12	0.656	126	102	16.00	25.250	26.500	12	0.656	191	144
22CB500	1.00	22	8.00	25.250	26.500	12	0.656	115	103	16.00	25.250	26.500	12	0.656	186	159
24CB500	1.00	24	8.00	27.250	28.875	12	0.656	130	139	16.00	27.250	28.875	12	0.781	208	212
26CB525	1.00	26	8.50	29.250	30.750	12	0.781	144	178	17.00	29.250	30.750	12	0.781	234	278
28CB525	1.00	28	8.50	30.250	31.875	12	0.781	143	200	17.00	30.250	31.875	12	0.781	240	326
30CB525	1.00	30	8.50	33.000	34.750	12	0.781	166	271							
32CB525	1.00	32	8.50	35.250	36.750	14	0.781	177	327							
36CB525	1.00	36	8.50	39.250	40.750	16	0.781	199	462							
40CB525	1.00	40	8.50	43.250	44.750	16	0.781	220	631							
45CB525	1.00	45	8.50	48.250	49.750	16	0.781	248	893							

Size	①		②		No.	Dia.	lb	lb ft ²	D ₆	H ₉	H ₁₀	No.	Dia.	lb	lb ft ²						
	F	H ₁	D ₆	H ₉												L (Bolt)	Weight	Wk ²	L (Bolt)	Weight	Wk ²
																	Mass	J		Mass	J
																	kg	kg m ²		kg	kg m ²
12CB350	19	305	152	333,4	352,4	8	10	2,9	0,27	306	438,2	466,7	8	13	45	1,18					
14CB400	19	356	168	438,2	466,7	8	13	8,2	0,76	330	542,9	571,5	6	17	47	1,97					
16CB500	19	406	203	489,0	517,5	8	13	14	1,30	363	641,4	673,1	12	17	82	4,33					
18CB500	19	457	203	542,9	571,5	6	13	20	1,85	406	641,4	673,1	12	17	91	5,29					
20CB500	25	508	203	641,4	673,1	12	17	46	4,28	406	641,4	673,1	12	17	87	6,05					
22CB500	25	559	203	641,4	673,1	12	17	47	4,33	406	641,4	673,1	12	17	84	6,68					
24CB500	25	610	203	692,2	733,4	12	17	63	5,84	406	692,2	733,4	12	20	94	8,90					
26CB525	25	660	216	743,0	781,1	12	20	81	7,48	432	743,0	781,1	12	20	106	11,68					
28CB525	25	711	216	768,4	809,6	12	20	91	8,40	432	768,4	809,6	12	20	109	13,69					
30CB525	25	762	216	838,2	882,7	12	20	123	11,38												
32CB525	25	813	216	895,4	933,5	14	20	148	13,73												
36CB525	25	914	216	997,0	1035,1	16	20	209	19,40												
40CB525	25	1016	216	1098,6	1136,7	16	20	286	26,50												
45CB525	25	1143	216	1225,6	1263,7	16	20	405	37,51												

SI	Single & Dual		Single Drum						Dual Drum							
	Dimensions in millimeters															

Notes:

- ① Tolerance +0.000/-0.010 in (+0,00/-0,25 mm).
- ② Tolerance +0.003/-0.000 in (+0,08/-0,00 mm).

Airflex[®] CB Mounting Components



Form CB 420

Internal Flange Drums – Dimensional and Technical Data
Single and Dual sizes 6 to 45

Size	Part Numbers			Size	Part Numbers		
	Single Drum		Dual Drum		Single Drum		Dual Drum
	Thru Holes	Tapped Holes	Thru Holes		Thru Holes	Tapped Holes	Thru Holes
6CB200	407043	407044	N/A	22CB500	408287	408288	411865
8CB250	407045	407046	N/A	24CB500	407057	407058	411866
10CB300	407047	407048	N/A	26CB525	408289	408342	411867
12CB350	407049	407050	411860	28CB525	407059	407060	411868
14CB400	407051	407052	411861	30CB525	408343	408344	411869
16CB500	407053	407054	411862	32CB525	407061	407062	411870
18CB500	408285	408286	411863	36CB525	407063	407064	411871
20CB500	407055	407056	411864	40CB525	407065	407066	411872

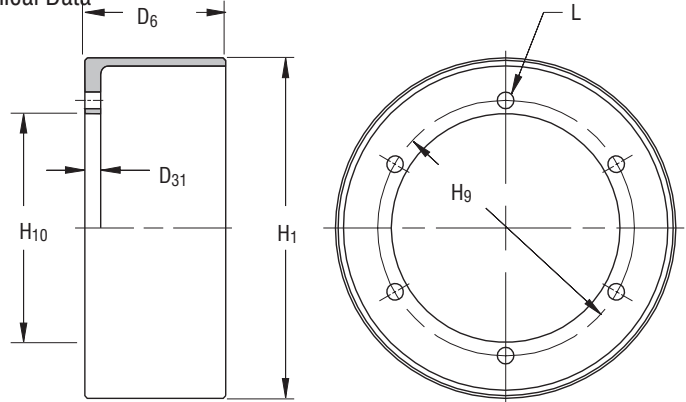

English	Dimensions in inches							Single Drum			Dual Drum		
	D ₃₁	H ₁	H ₉	H ₁₀	No.	Thru	Tapped ^④	in	lb	lb ft ²	in	lb	lb ft ²
6CB200	0.50	6	4.250	3.500	6	0.406	3/8-16	3.00	5.5	0.3			
8CB250	0.75	8	5.250	4.250	8	0.406	3/8-16	3.50	12.5	1.1			
10CB300	0.75	10	7.250	6.250	6	0.531	1/2-13	4.06	19	2.7			
12CB350	0.75	12	7.250	6.250	6	0.531	1/2-13	4.68	30	5.9	10.19	61	13
14CB400	0.75	14	9.250	8.250	6	0.531	1/2-13	5.18	38	10.5	11.19	83	24
16CB500	0.75	16	12.000	10.750	6	0.781	3/4-10	6.62	50	19	13.56	109	43
18CB500	1.00	18	13.500	12.125	8	0.781	3/4-10	6.62	67	31	13.56	126	63
20CB500	1.00	20	16.000	14.625	8	0.781	3/4-10	6.62	72	43	13.56	139	87
22CB500	1.00	22	18.500	16.750	10	0.781	3/4-10	6.62	79	58	13.56	152	117
24CB500	1.00	24	19.750	18.000	12	0.781	3/4-10	6.62	93	80	13.56	173	156
26CB525	1.00	26	21.500	19.500	14	0.781	3/4-10	7.06	108	110	14.19	198	211
28CB525	1.00	28	23.500	21.500	16	0.781	3/4-10	7.06	117	140	14.31	216	268
30CB525	1.00	30	25.000	23.000	18	0.781	3/4-10	7.06	140	192	14.31	237	337
32CB525	1.00	32	27.000	25.000	18	0.781	3/4-10	7.06	160	252	14.31	254	413
36CB525	1.00	36	31.000	29.000	20	0.781	3/4-10	7.06	180	319	14.31	287	597
40CB525	1.00	40	34.500	32.500	16	0.781	3/4-10	7.06	209	523	14.31	327	840
45CB525	1.00	45	39.500	37.500	10	1.031	3/4-10	7.06	237	758	14.31	369	1212

Size	Single & Dual Drum				No.	Thru	Tapped ^④	in	lb	lb ft ²	in	lb	lb ft ²							
	D ₃₁	H ₁	H ₉	H ₁₀										L (Bolt Holes)	D ₆	Weight	Wk ²	D ₆	Weight	Wk ²
	Single & Dual Drum																			
6CB200	13	152	108,0	88,9	6	10	3/8-16	76	2,5	0,01										
8CB250	19	203	133,4	108,0	8	10	3/8-16	89	5,7	0,05										
10CB300	19	254	184,2	158,8	6	13	1/2-13	103	8,6	0,11										
12CB350	19	305	184,2	158,8	6	13	1/2-13	119	14	0,25	259	28	0,55							
14CB400	19	356	235,0	209,6	6	13	1/2-13	132	17	0,44	284	38	1,01							
16CB500	19	406	304,8	273,1	6	20	3/4-10	168	23	0,80	344	49	1,81							
18CB500	25	457	342,9	308,0	8	20	3/4-10	168	30	1,30	344	57	2,65							
20CB500	25	508	406,4	371,5	8	20	3/4-10	168	33	1,81	344	63	3,65							
22CB500	25	559	469,9	425,5	10	20	3/4-10	168	36	2,44	344	69	4,91							
24CB500	25	610	501,7	457,2	12	20	3/4-10	168	42	3,36	344	78	6,55							
26CB525	25	660	546,1	495,3	14	20	3/4-10	179	49	4,62	360	90	8,86							
28CB525	25	711	596,9	546,1	16	20	3/4-10	179	53	5,88	363	98	11,26							
30CB525	25	762	635,0	584,2	18	20	3/4-10	179	63	8,06	363	107	14,15							
32CB525	25	813	685,8	635,0	18	20	3/4-10	179	72	10,58	363	115	17,35							
36CB525	25	914	787,4	736,6	20	20	3/4-10	179	81	13,40	363	130	25,07							
40CB525	25	1016	876,3	825,5	16	20	3/4-10	179	95	21,97	363	148	35,28							
45CB525	25	1143	1003,3	952,5	10	26	3/4-10	179	107	31,84	363	167	50,90							

Notes:

- ① Dual drum is only available with tapped holes only.
- ② Tolerance +0.000/-0.010 in (+0,00/-0,25 mm).
- ③ Tolerance for sizes:
6 thru 40 +0.003/-0.000 in (+0,08/-0,00 mm)
45 +0.005/-0.000 in (+0,13/-0,00 mm)
- ④ American National Standard for Unified Screw Threads.

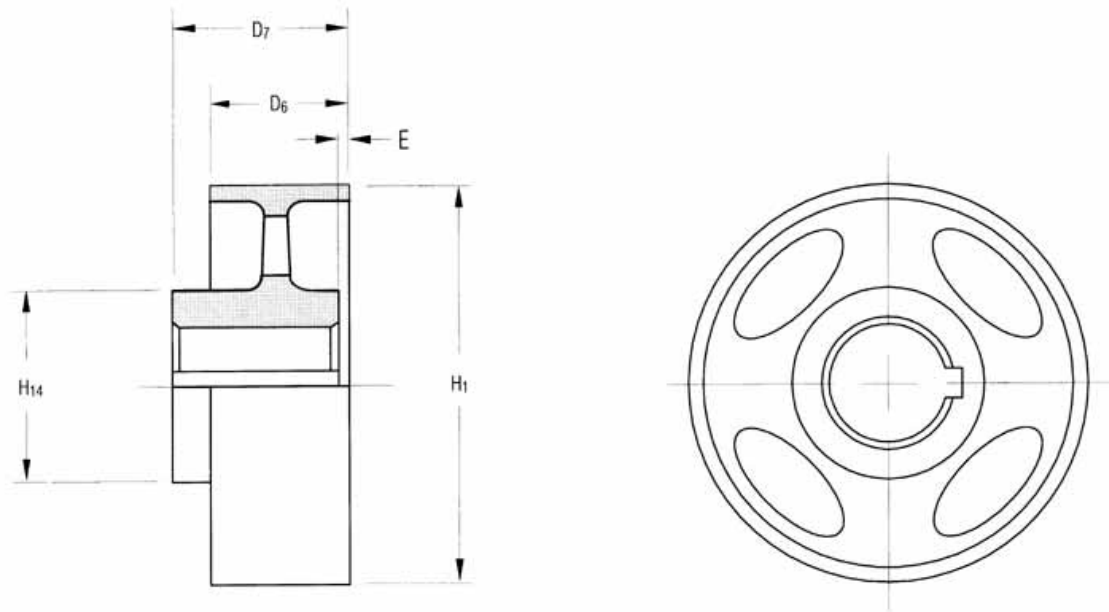

English		Dimensions in inches								
6CB200	10108	10	0.3	0.00	2.00	2.38	2.88	0.94	6	3.25
8CB250	10109	19	0.8	0.00	2.00	2.88	3.50	1.19	8	4.38
10CB300	10110	33	2.5	1.75	3.00	3.50	4.00	1.44	10	4.88
12CB350	10111	53	5.4	1.50	3.31	4.00	4.50	1.69	12	6.13
14CB400	09617	65	8.5	2.00	4.50	4.25	5.00	1.69	14	6.50
18CB500	402517	90	16	2.25	4.50	3.75	6.00	1.00	18	7.00
24CB500	502340	437	129	4.50	6.00	5.75	8.50	-	24	10.50
Size	Part Number	lb	lb ft ²	Bore		D ₆	D ₇	E ^②	H ₁	H ₁₄
		Weight ①	Wk ²	min.	max.					
		Mass	J							
		kg	kg m ²	min.	max.					
6CB200	10108	4,5	0,01	0	51	60	73	23,88	152	83
8CB250	10109	8,6	0,03	0	51	73	89	30,23	203	111
10CB300	10110	15	0,11	44	76	89	102	36,58	254	124
12CB350	10111	24	0,23	38	84	102	114	42,93	305	156
14CB400	09617	29	0,36	51	114	108	127	42,93	356	165
18CB500	402517	41	0,67	57	114	95	152	25,44	457	178
24CB500	502340	198	5,42	114	152	146	216	-	610	267
SI		Dimensions in millimeters								

Notes:

① Based upon minimum bores.

② This dimension is maximum and must be specified by customer.

Airflex® CB Mounting Components



Form CB 418

Drum Hub – Dimensional and Technical Data
Single and Dual sizes 6 to 45

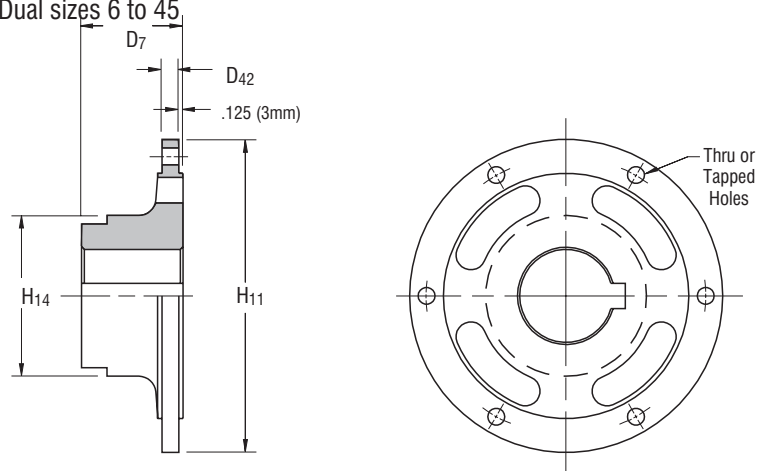

English				Dimensions in inches						
6CB200	408414	408415	9	0.50	1.50	2.50	2.75	0.63	5.00	3.75
8CB250	406900	406901	12	0.50	1.50	2.50	2.75	0.63	6.00	4.00
10CB300	406902	406903	18	0.88	1.50	3.00	3.25	0.63	8.25	5.00
12CB350	406902	406903	18	0.88	1.50	3.00	3.25	0.63	8.25	5.00
14CB400	406904	406905	46	3.50	2.25	4.50	5.00	0.63	10.25	7.00
16CB500	406906	406907	68	6.50	1.75	4.50	5.75	0.75	13.50	7.00
18CB500	406908	406909	74	6.50	2.25	4.75	5.75	0.75	15.00	7.50
20CB500	406910	406911	93	8.50	2.75	4.75	5.75	0.75	17.50	7.50
22CB500	406912	406913	131	29.00	2.75	5.25	6.50	0.75	20.00	8.50
24CB500	406914	406915	132	30.00	2.75	5.25	6.50	0.75	21.50	8.50
26CB525	406916	406917	160	46.00	2.75	5.50	6.50	0.75	23.00	9.00
28CB525	406918	406919	175	61.00	2.75	5.50	6.50	0.75	25.00	9.00
30CB525	406920	406921	214	78.00	3.00	6.00	8.00	0.75	26.50	9.50
32CB525	406922	406923	222	102.00	3.00	6.00	8.00	0.75	28.50	9.50
36CB525	406924	406925	305	159.00	4.00	7.00	9.00	0.75	32.50	11.00
40CB525	406926	406927	358	247.00	4.00	7.00	9.00	0.75	36.00	11.00
45CB525	406928	406929	541	461.00	4.38	8.25	10.00	0.75	41.50	13.50
Size	Thru Holes	Tapped Holes	lb	lb ft ²	min.	max.	D ₇	D ₄₂	H ₁₁	H ₁₄
	Part Number		Weight	Wk ²	Bore					
	Thru Holes	Tapped Holes	Mass	J	min.	max.				
			kg	kg m ²	min.	max.				
6CB200	408414	408415	4,1	0,02	38	64	70	16	127	95
8CB250	406900	406901	5,4	0,02	38	64	70	16	152	102
10CB300	406902	406903	8,2	0,04	38	76	83	16	210	127
12CB350	406902	406903	8,2	0,04	38	76	83	16	210	127
14CB400	406904	406905	21	0,15	57	114	127	16	260	178
16CB500	406906	406907	31	0,27	44	114	146	19	343	178
18CB500	406908	406909	34	0,27	57	121	146	19	381	191
20CB500	406910	406911	42	0,36	70	121	146	19	445	191
22CB500	406912	406913	59	1,22	70	133	165	19	508	216
24CB500	406914	406915	60	1,26	70	133	165	19	546	216
26CB525	406916	406917	72	1,93	70	140	165	19	584	229
28CB525	406918	406919	79	2,56	70	140	165	19	635	229
30CB525	406920	406921	97	3,28	76	152	203	19	673	241
32CB525	406922	406923	101	4,28	76	152	203	19	724	241
36CB525	406924	406925	138	6,68	102	178	229	19	826	279
40CB525	406926	406927	162	10,37	102	178	229	19	914	279
45CB525	406928	406929	245	19,36	111	210	254	19	1054	343
SI				Dimensions in millimeters						

Notes:

① Based upon minimum bores.