

**FRIZIONI ELETTRROMAGNETICHE  
LAMELLARI A MOLLE  
Serie FML**

**MULTIPLATE SPRING LOADED  
ELECTROMAGNETIC CLUTCHES  
Model FML**

**PRESTAZIONI ( 24VCC ) • PERFORMANCES ( 24VDC )**

tipo - size	coppia - torque (nm)		tempo - time		potenza - power (W)		peso - weight (kg)	dischi - plates int/est
	M <sub>d</sub>	M <sub>s</sub>	inserzione engagement	disinserz disengag	20°	120°		
FML 114	25	40	120	70	110	80	5	2/3
FML 140	50	70	200	80	92	68	7	2/3
FML 166	100	140	280	90	98	78	13	3/4
FML 195	200	260	360	100	140	100	20	3/4

- Per inserzioni in movimento riferirsi ai valori di coppia dinamica M<sub>d</sub> / for engagement in motion refer to dynamic torque M<sub>d</sub>
- Per inserzioni da fermo o per frizione già inserita riferirsi ai valori di coppia statica M<sub>s</sub> / for stationary engagement or for engaged clutches refer to static torque M<sub>s</sub>

**DIMENSIONI (mm) • DIMENSIONS (mm)**

tipo - size	A	B	C	D	E n°x Ø	F	G	H	J	K	L	M	P	Q
FML 114	84	114	25	58	4XM8	69	65	114	6	23	10	8,5	26,7	8
FML 140	93	140	25	72	4XM8	74	71	140	7	27	13	8,5	26,7	8
FML 166	104	166	30	84	4XM10	79	76	165	7	28	13	10,5	31,7	8
FML 195	113	195	30	108	4XM12	87	83	195	7	33	15	12,5	52,6	14

**NOME PARTICOLARI • PARTS NAME**

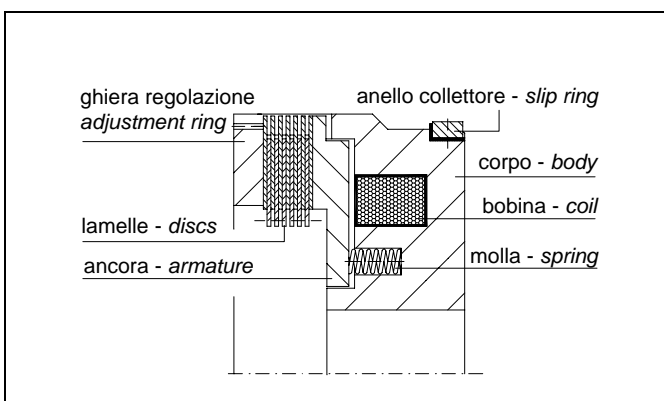

**ESEMPIO MONTAGGIO • MOUNTING EXAMPLE**

